

The background of the cover is a light pink color with a pattern of small black dots. Scattered across this background are various-sized squares in shades of pink and black. The title is centered in a dark blue, serif font.

**SUBSET NON  
ASSOCIATIVE SEMIRINGS**

**W.B.VASANTHA KANDASAMY  
FLORENTIN SMARANDACHE**

# Subset Non Associative Semirings

**W. B. Vasantha Kandasamy  
Florentin Smarandache**

**Educational Publisher Inc.  
Ohio  
2013**

This book can be ordered from:

Education Publisher Inc.  
1313 Chesapeake Ave.  
Columbus, Ohio 43212,  
USA  
Toll Free: 1-866-880-5373

Copyright 2013 by *Educational Publisher Inc.* and the *Authors*

Peer reviewers:

Prof. Xingsen Li, School of Management, Ningbo Institute of Technology,  
Zhejiang University, Ningbo 315100, P. R. China

Said Broumi, University of Hassan II Mohammedia, Hay El Baraka Ben  
M'sik, Casablanca B. P. 7951, Morocco

Prof. Valeri Kroumov, Dept. of Electrical and Electronic Engineering, Faculty  
of Engineering, Okayama University of Science, 1-1, Ridai-cho, Kita-ku,  
Okayama

Florentin Popescu, Facultatea de Mecanica, University of Craiova, Romania.

Many books can be downloaded from the following  
Digital Library of Science:

<http://www.gallup.unm.edu/eBooks-otherformats.htm>

**ISBN-13: 978-1-59973-225-1**

**EAN: 9781599732251**

**Printed in the United States of America**

# CONTENTS

Dedication	4
Preface	5
Chapter One <b>BASIC CONCEPTS</b>	7
Chapter Two <b>SUBSET NON ASSOCIATIVE SEMIRINGS USING GROUPOIDS</b>	11
Chapter Three <b>SUBSET NON ASSOCIATIVE SEMIRINGS USING LOOPS</b>	97
<b>FURTHER READING</b>	195
<b>INDEX</b>	203
<b>ABOUT THE AUTHORS</b>	207

# DEDICATION

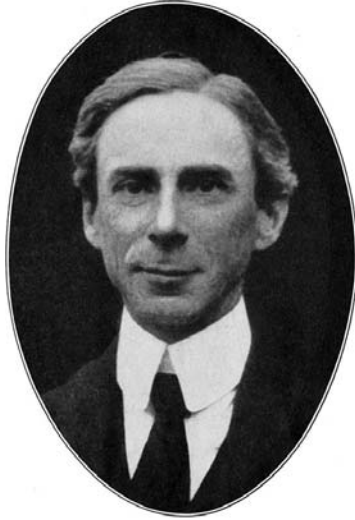

*BERTRAND RUSSELL*  
*(18 May 1872 – 2 February 1970)*



## PREFACE

In this book for the first time we introduce the notion of subset non associative semirings. It is pertinent to keep on record that study of non associative semirings is meager and books on this specific topic is still rare. Authors have recently introduced the notion of subset algebraic structures. The maximum algebraic structure enjoyed by subsets with two binary operations is just a semifield and semiring, even if a ring or a field is used. In case semigroups or groups are used still the algebraic structure of the subset is only a semigroup.

To construct a subset non associative semiring we use either a non associative ring or a non associative semiring. This study is innovative and interesting. We construct subset non associative semirings using groupoids. We define notions like Smarandache non associative subset semirings, sub structures in them and study their properties.

Finite subset non associative semirings are constructed using the groupoid lattice  $LP$  where  $L$  is a finite distributive lattice and  $P$  is a groupoid of finite order. Using also loop lattice we can have finite subset non associative semirings. When in the place of the lattice a semiring is used we get non associative semirings and the collection all subsets of them form a subset non associative semiring.

When semirings are replaced by rings using groupoids we get groupoid rings. Groupoid ring are also non associative and their subset collection gives non associative subset semirings only. Elaborate study about these structures is carried out in this book.

When subset non associative structures are constructed using loops these subset semirings enjoy many special properties which are discussed in this book. Further new notions like subset idempotents, subset zero divisors and subset units are introduced and studied.

Over 250 problems are suggested in this book some at usual level and some of them are open problems which cannot be solved easily.

Certainly in due course of time they will find lots of more applications in fields where loops, groupoids and semirings find their applications.

We thank Dr. K.Kandasamy for proof reading and being extremely supportive.

W.B.VASANTHA KANDASAMY  
FLORENTIN SMARANDACHE

## Chapter One

# BASIC CONCEPTS

In this chapter we mainly mention the availability of the literature from the books where references can be got, we just give only a line or two to indicate from which book it is taken.

We use the concept of finite groupoids from the book [70]. In this book for the first time the structure of finite groupoid is made non abstract by building it using modulo integers  $Z_n$ .

**DEFINITION 1.1:** *Let  $G$  be a non empty set with a binary operation  $*$  defined on  $G$ . That is for all  $a, b \in G$ ;*

*$a * b \in G$  and  $*$  in general is non associative on  $G$ . We define  $(G, *)$  to be a groupoid.*

We may have groupoids of infinite or finite order.

**Example 1.1:** Let  $G = \{a_0, a_1, a_2, a_3, a_4\}$  be the groupoid given by the following table:



*	$a_0$	$a_1$	$a_2$	$a_3$	$a_4$
$a_0$	$a_0$	$a_4$	$a_3$	$a_2$	$a_1$
$a_1$	$a_1$	$a_0$	$a_4$	$a_3$	$a_2$
$a_2$	$a_2$	$a_1$	$a_0$	$a_4$	$a_3$
$a_3$	$a_3$	$a_2$	$a_1$	$a_0$	$a_4$
$a_4$	$a_4$	$a_3$	$a_2$	$a_1$	$a_0$

The concept of semirings and non associative semirings can be had from [73]. An elaborate dealing of semirings is done in this book, for books on semirings are very rare.

The notion of loops and loop rings can be had from [71-2, 74-5]. Loop structures are also constructed using modulo integers of odd order.

Construction of a new class of loops.

Let  $L_n(m) = \{e, 1, 2, \dots, n\}$ ;  $n > 3$  and  $n$  is an odd integer.  $m$  is a positive integer such that  $m < n$  and  $(m, n) = 1$  and  $(m - 1, n) = 1$  with  $m < n$ .

Define on  $L_n(m)$  a binary operation  $*$  as follows:

- (i)  $e * i = i * e = i$  for all  $i \in L_n(m)$
- (ii)  $i * i = e$  for all  $i \in L_n(m)$
- (iii)  $i * j = t$  where  $t = (m_j - (m - 1)i) \pmod{n}$  for all  $i, j \in L_n(m)$ ,  $i \neq j$ ,  $i \neq e$  and  $j \neq e$ .

Then  $L_n(m)$  is a loop. We give one example.

Consider the following the table of  $L_7(4) = \{e, 1, 2, 3, 4, 5, 6, 7\}$  which is as follows:

*	e	1	2	3	4	5	6	7
e	e	1	2	3	4	5	6	7
1	1	e	5	2	6	3	7	4
2	2	5	e	6	3	7	4	1
3	3	2	6	e	7	4	1	5
4	4	6	3	7	e	1	5	2
5	5	3	7	4	1	e	2	6
6	6	7	4	1	5	2	e	3
7	7	4	1	5	2	6	3	e

is a loop of order 8. We just give the physical interpretation of the operation in the loop  $L_n(m)$ .

We denote by ‘I’ by the indeterminate;  $I^2 = I$  and for the notion of neutrosophic rings refer [52, 80]. The concept of finite neutrosophic complex modulo integers can be had from [82].

Further for the notion of dual numbers, special dual like numbers and special quasi dual numbers refer [83, 87-8].

Finally the concept of non associative subset new topological space can be better understood by referring [85].

Throughout this book;

$$C(Z_n) = \{a + bi_F \mid a, b \in Z_n, i_F^2 = n-1\}$$

denotes the finite complex modulo integers.

$\langle Z \cup I \rangle, \langle Q \cup I \rangle, \langle R \cup I \rangle, \langle C \cup I \rangle$  and  $\langle Z_n \cup I \rangle$  are the neutrosophic rings.

$\langle Z^+ \cup I \rangle \cup \{0\}, \langle Q^+ \cup I \rangle \cup \{0\}$  and  $\langle R^+ \cup I \rangle \cup \{0\}$  denote the collection of all neutrosophic semirings.

$L_n(m)$  will denote a finite loop of even order  $n + 1$ , with  $n > 3$ , an odd number and  $m < n$  with  $(m, n) = 1 = (n-1, m)$ .

For the concept of Smarandache zero divisors, Smarandache idempotents, Smarandache semirings, Smarandache rings etc refer [79].

## Chapter Two

# SUBSET NON ASSOCIATIVE SEMIRINGS USING GROUPOIDS

In this chapter we for the first time study the new concept of subset non associative semirings using groupoids. It is pertinent to keep on record that it is difficult to define semirings which are not rings, that are non associative. We using the notion of subsets easily define non associative subset semirings which are not rings. These non associative subset semirings are basically constructed using groupoid rings and groupoid semirings and subset groupoid rings and subset groupoid semirings.

**DEFINITION 2.1:** *Let  $S = \{\text{Collection of all subsets of } R; \text{ a groupoid ring or a groupoid semiring}\}$ ;  $S$  under the operations  $\cup_g$  and  $\cap_g$  is a semiring defined as the subset non associative semiring; where  $\cup_g$  is '+' of  $R$  and  $\cap_g$  is the  $\times$  on  $R$ .*

We will first illustrate this situation by some examples.

**Example 2.1:** Let  $S = \{\text{Collection of all subsets of the groupoid ring } Z_5G \text{ with } G = \{g_1, g_2, \dots, g_6\} \text{ where } g_1 = 1, g_2 = 2, g_3 = 3, g_4 = 4, g_5 = 5 \text{ and } g_6 = 0 \text{ with } *, (g_3, g_6); \text{ that is};$

$$\begin{aligned}
 g_4 * g_2 &= g_3 * g_4 + g_2 * g_6 \\
 &= g_6 + g_6 = g_6 \\
 g_1 * g_2 &= g_3 g_1 * g_6 g_2 \\
 &= g_3 + g_6 = g_3 \text{ and so on} \}
 \end{aligned}$$

be the subset non associative semiring of the groupoid ring  $Z_5G$ . Clearly  $S$  is a non associative subset semiring.

Let  $A = \{3g_1\}$  and  $B = \{4g_2\} \in S$ .  $A + B = \{3g_1 + 4g_2\}$  that is '+' operation on  $G$  is used, which is the  $\cup_g$  given in definition.

$$A + B = B + A \text{ for all } A, B \in S.$$

$$\begin{aligned}
 A * B &= \{3g_1 * 4g_2\} \\
 &= \{3 \times 4 (g_1 * g_2)\} \\
 &= \{12 [g_3g_1 + g_6g_2]\} \\
 &= \{12 [g_3 + g_6]\} \\
 &= \{2 [g_3 + g_6]\} \text{ (* is the } \cap_g \text{ given in the definition).}
 \end{aligned}$$

However  $A * B \neq B * A$  for all  $A, B \in S$  and  $(A * B) * C \neq A * (B * C)$  in general for all  $A, B, C \in S$ .

$$\text{Let } A = \{2g_1 + g_2\}, B = \{3g_1 + 4g_3\} \text{ and } C = \{g_5\} \in S.$$

Consider

$$\begin{aligned}
 A * B &= \{2g_1 + g_2 * 3g_1 + 4g_3\} \\
 &= \{2g_1 * 3g_1 + g_2 * 3g_1 + 2g_1 * 4g_3 + g_2 * 4g_3\} \\
 &= \{2g_1g_3 + 3g_1g_6 + g_2g_3 + 3g_1g_6 + 2g_1g_3 + 4g_3g_6 + \\
 &\quad g_2g_3 + 4g_3g_6\} \\
 &= \{2g_3 + 3g_6 + g_6 + 3g_6 + 2g_3 + 4g_6 + g_6 + 4g_6\} \\
 &= \{4g_3 + g_6\} \qquad \qquad \qquad \dots \qquad \qquad \qquad \text{I}
 \end{aligned}$$

Consider

$$\begin{aligned}
 B * A &= \{3g_1 + 4g_3 * 2g_1 + g_2\} \\
 &= \{3g_1 * 2g_1 + 3g_1 * g_2 + 4g_3 * 2g_1 + 4g_3 * g_2\}
 \end{aligned}$$

$$\begin{aligned}
 &= \{3g_1g_3 + 2g_1g_6 + 3g_1g_3 + g_2g_6 + 4g_3g_3 + 2g_1g_6 \\
 &\quad + 4g_3g_3 + g_2g_6\} \\
 &= \{3g_3 + 2g_6 + 3g_3 + g_6 + 4g_3 + 2g_6 + 4g_3 + g_6\} \\
 &= \{4g_3 + g_6\} \qquad \qquad \qquad \dots \qquad \qquad \qquad \text{II}
 \end{aligned}$$

I and II are equal.

Take  $A = \{g_3\}$ ,  $B = \{g_2\}$  and  $C = \{g_4\} \in S$

$$\begin{aligned}
 (A * B) * C &= \{g_3 * g_2\} * C \\
 &= \{g_3 \times g_3 + g_2 \times g_6\} * C \\
 &= \{g_3 + g_6\} * g_4 \\
 &= g_3g_3 + g_4g_6 + g_6g_3 + g_4g_6 \\
 &= g_3 + g_6 + g_6 + g_6 \\
 &= \{g_3 + 3g_6\} \qquad \qquad \qquad \dots \qquad \qquad \qquad \text{I}
 \end{aligned}$$

$$\begin{aligned}
 A (B * C) &= A * \{g_2 * g_4\} \\
 &= A * \{g_2g_3 + g_4g_6\} \\
 &= A * \{2g_6\} \\
 &= \{g_3 * 2g_6\} \\
 &= \{g_3g_3 + 2g_6g_6\} \\
 &= \{g_3 + 2g_6\} \qquad \qquad \qquad \dots \qquad \qquad \qquad \text{II}
 \end{aligned}$$

Clearly I and II are distinct so the operation on S in general is non associative.

Let  $A = \{g_1\}$  and  $B = \{g_2\}$  be in S.

$$\begin{aligned}
 A * B &= \{g_1 * g_2\} \\
 &= \{g_1g_3 + g_2g_6\} \\
 &= \{g_3 + g_6\} \qquad \qquad \qquad \dots \qquad \qquad \qquad \text{I}
 \end{aligned}$$

$$\begin{aligned}
 B * A &= \{g_2 * g_1\} \\
 &= \{g_2 * g_3 + g_1g_6\} \\
 &= \{g_6 + g_6\} \\
 &= \{2g_6\} \qquad \qquad \qquad \dots \qquad \qquad \qquad \text{II}
 \end{aligned}$$

I and II are not equal so  $A * B \neq B * A$  in general for A, B  $\in S$ . Thus  $\{S, +, *\}$  is a non associative semiring of finite order which is also non commutative.

**Example 2.2:** Let  $S = \{\text{Collection of all subsets of the groupoid semiring } (Z^+ \cup \{0\})G\}$  be a subset non associative semiring of the groupoid semiring  $(Z^+ \cup \{0\})G$  where  $G$  is given by the following table;

*	$x_0$	$x_1$	$x_2$	$x_3$	$x_4$	$x_5$	$x_6$	$x_7$
$x_0$	$x_0$	$x_6$	$x_4$	$x_2$	$x_0$	$x_6$	$x_4$	$x_2$
$x_1$	$x_2$	$x_0$	$x_6$	$x_4$	$x_2$	$x_0$	$x_6$	$x_4$
$x_2$	$x_4$	$x_2$	$x_0$	$x_6$	$x_4$	$x_2$	$x_0$	$x_6$
$x_3$	$x_6$	$x_4$	$x_2$	$x_0$	$x_6$	$x_4$	$x_2$	$x_0$
$x_4$	$x_0$	$x_6$	$x_4$	$x_2$	$x_0$	$x_6$	$x_4$	$x_2$
$x_5$	$x_2$	$x_0$	$x_6$	$x_4$	$x_2$	$x_0$	$x_6$	$x_4$
$x_6$	$x_4$	$x_2$	$x_0$	$x_6$	$x_4$	$x_2$	$x_0$	$x_6$
$x_7$	$x_6$	$x_4$	$x_2$	$x_0$	$x_6$	$x_4$	$x_2$	$x_0$

Take  $A = \{8x_1 + 3x_2, 5x_7, 2x_5\}$  and  $B = \{2x_0, 4x_3\} \in S$ .

To find  $A + B$  and  $A * B$ .

Clearly

$$A + B = \{8x_1 + 3x_2 + 2x_0, 8x_1 + 3x_2 + 4x_3, 5x_7 + 2x_0, 5x_7 + 4x_3, 2x_5 + 2x_0, 2x_5 + 4x_3\} \text{ is in } S.$$

Consider

$$\begin{aligned} A * B &= \{(8x_1 + 3x_2) * 2x_0, 5x_7 * 2x_0, 2x_5 * 2x_0, \\ &\quad (8x_1 + 3x_2) * 4x_3, 5x_7 * 4x_3, 2x_5 * 4x_3\} \\ &= \{16x_2 + 6x_4, 10x_6, 4x_2, 32x_4 + 12x_6, 20x_0, 8x_4\} \in S. \end{aligned}$$

Consider

$$\begin{aligned} B * A &= \{2x_0 * (8x_1 + 3x_2), 2x_0 * 5x_7, 2x_0 * 2x_5, 4x_3 * \\ &\quad (8x_1 + 3x_2), 4x_3 * 5x_7, 4x_3 * 2x_5\} \\ &= \{16x_6 + 6x_4, 10x_2, 4x_6, 32x_4 + 12x_2, 20x_0, 8x_4\} \in S. \end{aligned}$$

We see  $A * B \neq B * A$ . Thus  $S$  is a non commutative subset semiring of the groupoid semiring. Let us take  $A = \{5x_2, x_3\}$ ,  $B = \{3x_7\}$  and  $C = \{x_4, 8x_5\} \in S$ .

To find

$$\begin{aligned}
 (A * B) * C &= (\{5x_2, x_3\} * \{3x_7\}) * C \\
 &= \{5x_2 * 3x_7, x_3 * 3x_7\} * C \\
 &= \{15x_6, 3x_0\} * \{x_4, 8x_5\} \\
 &= \{15x_6 * x_4, 3x_0 * x_4, 120x_6 * x_5, 24x_0 * x_5\} \\
 &= \{15x_4, x_0, 120x_2, 24x_6\} \quad \dots \quad I
 \end{aligned}$$

Now we find

$$\begin{aligned}
 A * (B * C) &= A * (\{3x_7\} * \{x_4, 8x_5\}) \\
 &= A * \{3x_7 * x_4, 24x_7 * x_5\} \\
 &= A * \{3x_6, 24x_4\} \\
 &= \{5x_2, x_3\} * \{3x_6, 24x_4\} \\
 &= \{15x_2 * x_6, 3x_3 * x_6, 120x_2 * x_4, 24x_3 * x_4\} \\
 &= \{15x_0, 3x_2, 120x_4, 24x_6\} \quad \dots \quad II
 \end{aligned}$$

Clearly  $(A * B) * C \neq A * (B * C)$ , as I and II are different. Thus  $S$  is a subset non associative, non commutative semiring of infinite order.

**Example 2.3:** Let  $S = \{\text{Collection of all subsets of the groupoid ring } Z_{10}G \text{ where } G \text{ is given by the following table;}\}$

*	$a_0$	$a_1$	$a_2$	$a_3$	$a_4$
$a_0$	$a_0$	$a_4$	$a_3$	$a_2$	$a_1$
$a_1$	$a_1$	$a_0$	$a_4$	$a_3$	$a_2$
$a_2$	$a_2$	$a_1$	$a_0$	$a_4$	$a_3$
$a_3$	$a_3$	$a_2$	$a_1$	$a_0$	$a_4$
$a_4$	$a_4$	$a_3$	$a_2$	$a_1$	$a_0$



be the subset non associative semiring of finite order of the groupoid ring  $Z_{10}G$ .

For  $A = \{5a_0, 5a_4\}$  and  $B = \{2a_1, 2a_0 + 4a_3, 4a_1 + 2a_2, 6a_3\}$  in  $S$  we see  $A * B = \{0\}$  and  $B * A = \{0\}$ .

Thus  $S$  has subset zero divisors.

Take  $A = \{4a_3\}$  and  $B = \{2a_1 + 3a_2, a_4\} \in S$ .

We now find

$$\begin{aligned} A * B &= \{4a_3\} * \{2a_1 + 3a_2, a_4\} \\ &= \{4a_3 * (2a_1 + 3a_2), 4a_3 * a_4\} \\ &= \{8a_3 * a_1 + 12a_3 * a_2, 4a_3 * a_4\} \\ &= \{8a_2 + 2a_1, 4a_4\} \quad \dots \quad \text{I} \end{aligned}$$

Consider

$$\begin{aligned} B * A &= \{2a_1 + 3a_2, a_4\} * \{4a_3\} \\ &= \{(2a_1 + 3a_2) * 4a_3, a_4 * 4a_3\} \\ &= \{8a_1 * a_3 + 2a_2 * a_3, 4a_4 * a_3\} \\ &= \{8a_3 + 2a_4, 4a_1\} \quad \dots \quad \text{II} \end{aligned}$$

Clearly I and II are not equal so  $S$  is not a commutative subset semiring.

Take  $C = \{8a_1, 4a_2\} \in S$ .

We find for the same  $A, B \in S$ ;  $(A * B) * C$  and  $A * (B * C)$ .

Clearly  $(A * B) * C$

$$= \{8a_2 + 2a_1, 4a_4\} * \{8a_1, 4a_2\}$$

(from equation I we have put value of  $A * B$ )

$$\begin{aligned} &= \{(8a_2 + 2a_1) * 8a_1, (8a_2 + 2a_1) * 4a_2, 4a_4 * 8a_1, 4a_4 * 4a_2\} \\ &= \{4a_1 * a_2 + 6a_1 * a_1, 2a_2 * a_2 + 8a_1 * a_2, 2a_4 * a_1, 6a_4 * a_2\} \\ &= \{4a_4 + 6a_0, 2a_0 + 8a_4, 2a_3, 6a_2\} \quad \dots \quad \text{I} \end{aligned}$$

Consider  $A * (B * C)$

$$\begin{aligned}
 &= A * (\{2a_1 + 3a_2, a_4\} \times \{8a_1, 4a_2\}) \\
 &= A * \{6a_1 * a_1 + 4a_2 * a_1, 8a_4 * a_1, 8a_1 * a_2 + 2a_2 * a_2, \\
 &\quad 4a_4 * a_2\} \\
 &= \{4a_3\} * \{6a_0 + 4a_1, 8a_3, 8a_4 + 2a_0, 4a_2\} \\
 &= \{4a_3 * a_0 + 6a_3 * a_1, 2a_3 * a_3, 2a_3 * a_4 + 8a_3 * a_0, 6a_3 * a_2\} \\
 &= \{4a_3 + 6a_1, 2a_0, 2a_4 + a_3, 6a_1\} \quad \dots \text{ II}
 \end{aligned}$$

I and II are distinct so  $(A * B) * C \neq A * (B * C)$  in general for  $A, B, C \in S$ .

Thus  $S$  is a non commutative, non associative subset semiring of finite order. But  $S$  has subset zero divisors.

**Example 2.4:** Let  $S = \{\text{Collection of all subsets of the groupoid ring } Z_3G \text{ where } G \text{ is given by the following table};$

*	$g_0$	$g_1$	$g_2$	$g_3$	$g_4$	$g_5$	$g_6$
$g_0$	$g_0$	$g_4$	$g_1$	$g_5$	$g_2$	$g_6$	$g_3$
$g_1$	$g_3$	$g_0$	$g_4$	$g_1$	$g_5$	$g_2$	$g_6$
$g_2$	$g_6$	$g_3$	$g_0$	$g_4$	$g_1$	$g_5$	$g_2$
$g_3$	$g_2$	$g_6$	$g_3$	$g_0$	$g_4$	$g_1$	$g_5$
$g_4$	$g_5$	$g_2$	$g_6$	$g_3$	$g_0$	$g_4$	$g_1$
$g_5$	$g_1$	$g_5$	$g_2$	$g_6$	$g_3$	$g_0$	$g_4$
$g_6$	$g_4$	$g_1$	$g_5$	$g_2$	$g_6$	$g_3$	$g_0$

be the subset non associative semiring of the groupoid ring  $Z_3G$ . Clearly  $S$  is both non associative and non commutative and is of finite order. Clearly  $S$  has no subset idempotents or subset zero divisors.

**Example 2.5:** Let  $S = \{\text{Collection of all subsets of the groupoid lattice } LG \text{ where } L \text{ is the lattice given by}$

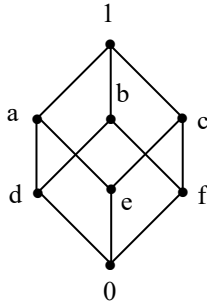

and  $G$  is a groupoid given by the following table;

$\times$	$g_0$	$g_1$	$g_2$	$g_3$	$g_4$	$g_5$	$g_6$	$g_7$
$g_0$	$g_0$	$g_6$	$g_4$	$g_2$	$g_0$	$g_6$	$g_4$	$g_2$
$g_1$	$g_2$	$g_0$	$g_6$	$g_4$	$g_2$	$g_0$	$g_6$	$g_4$
$g_2$	$g_4$	$g_2$	$g_0$	$g_6$	$g_4$	$g_2$	$g_0$	$g_6$
$g_3$	$g_6$	$g_4$	$g_2$	$g_0$	$g_6$	$g_4$	$g_2$	$g_0$
$g_4$	$g_0$	$g_6$	$g_4$	$g_2$	$g_0$	$g_6$	$g_4$	$g_2$
$g_5$	$g_2$	$g_0$	$g_6$	$g_4$	$g_2$	$g_0$	$g_6$	$g_4$
$g_6$	$g_4$	$g_2$	$g_0$	$g_6$	$g_4$	$g_2$	$g_0$	$g_6$
$g_7$	$g_6$	$g_4$	$g_2$	$g_0$	$g_6$	$g_4$	$g_2$	$g_0$

be the subset semiring. Clearly  $S$  is a non associative subset semiring. Further  $S$  is also a non commutative subset semiring.  $S$  is of finite order and  $S$  has subset zero divisors.

Let  $A = \{dg_6 + eg_1 + eg_4, dg_1 + eg_5\}$  and  $B = \{fg_1 + fg_3, fg_5\} \in S$ . It is easily verified  $A * B = \{0\}$ . Thus  $S$  has subset zero divisors.

However we do not know whether we have a set  $P \in S$  such that  $P * P = \{0\}$ .

**Example 2.6:** Let  $S = \{\text{Collection of all subsets from the lattice groupoid (groupoid lattice) } LG \text{ where } L \text{ is a chain lattice given by } C_9 =$

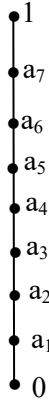

and  $G$  is the groupoid given by the following table;

*	$g_0$	$g_1$	$g_2$	$g_3$	$g_4$	$g_5$
$g_0$	$g_0$	$g_5$	$g_4$	$g_3$	$g_2$	$g_1$
$g_1$	$g_4$	$g_3$	$g_2$	$g_1$	$g_0$	$g_5$
$g_2$	$g_2$	$g_1$	$g_0$	$g_5$	$g_4$	$g_3$
$g_3$	$g_0$	$g_5$	$g_4$	$g_3$	$g_2$	$g_1$
$g_4$	$g_4$	$g_3$	$g_2$	$g_1$	$g_0$	$g_5$
$g_5$	$g_2$	$g_1$	$g_0$	$g_5$	$g_4$	$g_3$

be the subset non associative semiring.

We see  $S$  has no subset zero divisors. But  $S$  has subset idempotents.

$A = \{a_1g_3, a_2g_3, g_3\}$  is such that  $A * A = A$ . So this subset semiring has no subset zero divisors but has subset idempotents.

**Example 2.7:** Let  $S = \{\text{Collection of all subsets of the groupoid semiring } LG \text{ where } L \text{ is the lattice given by}$

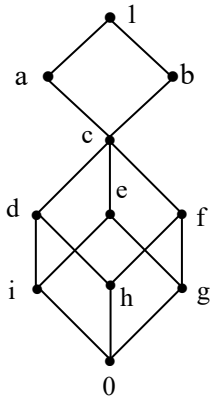

and table for G is as follows;

*	$g_0$	$g_1$	$g_2$	$g_3$	$g_4$	$g_5$	$g_6$	$g_7$	$g_8$	$g_9$	$g_{10}$	$g_{11}$
$g_0$	$g_0$	$g_4$	$g_8$	$g_0$	$g_4$	$g_8$	$g_0$	$g_4$	$g_8$	$g_0$	$g_4$	$g_8$
$g_1$	$g_3$	$g_7$	$g_{11}$	$g_3$	$g_7$	$g_{11}$	$g_3$	$g_7$	$g_{11}$	$g_3$	$g_7$	$g_{11}$
$g_2$	$g_6$	$g_{10}$	$g_2$	$g_6$	$g_{10}$	$g_2$	$g_6$	$g_{10}$	$g_2$	$g_6$	$g_{10}$	$g_2$
$g_3$	$g_9$	$g_1$	$g_5$	$g_9$	$g_1$	$g_5$	$g_9$	$g_1$	$g_5$	$g_9$	$g_1$	$g_5$
$g_4$	$g_0$	$g_4$	$g_8$	$g_0$	$g_4$	$g_8$	$g_0$	$g_4$	$g_8$	$g_0$	$g_4$	$g_8$
$g_5$	$g_3$	$g_7$	$g_{11}$	$g_3$	$g_7$	$g_{11}$	$g_3$	$g_7$	$g_{11}$	$g_3$	$g_7$	$g_{11}$
$g_6$	$g_6$	$g_{10}$	$g_2$	$g_6$	$g_{10}$	$g_2$	$g_6$	$g_{10}$	$g_2$	$g_6$	$g_{10}$	$g_2$
$g_7$	$g_9$	$g_1$	$g_5$	$g_9$	$g_1$	$g_5$	$g_9$	$g_1$	$g_5$	$g_9$	$g_1$	$g_5$
$g_8$	$g_0$	$g_4$	$g_8$	$g_0$	$g_4$	$g_8$	$g_0$	$g_4$	$g_8$	$g_0$	$g_4$	$g_8$
$g_9$	$g_3$	$g_7$	$g_{11}$	$g_3$	$g_7$	$g_{11}$	$g_3$	$g_7$	$g_{11}$	$g_3$	$g_7$	$g_{11}$
$g_{10}$	$g_6$	$g_{10}$	$g_2$	$g_6$	$g_{10}$	$g_2$	$g_6$	$g_{10}$	$g_2$	$g_6$	$g_{10}$	$g_2$
$g_{11}$	$g_9$	$g_1$	$g_5$	$g_9$	$g_1$	$g_5$	$g_9$	$g_1$	$g_5$	$g_9$	$g_1$	$g_5$

be the subset non associative semiring. Clearly S has subset idempotents and subset zero divisors.

Further S is both non commutative and non associative subset semiring of finite order.

We take  $A = \{ag_5\}$ ,  $B = \{dg_1\}$  and  $C = \{hg_3\} \in S$ .

We find

$$\begin{aligned}
 & ((A * B) * C) * B \\
 &= ((\{ag_5\} * \{dg_1\}) * C) * B \\
 &= (\{dg_7\} * \{hg_3\}) * \{dg_1\} = \{dhg_7 * g_3\} * \{dg_1\} \\
 &= \{hg_9\} * \{dg_1\} \\
 &= \{hdg_9 * g_1\} \\
 &= \{hg_7\} \qquad \dots \qquad I
 \end{aligned}$$

Consider

$$\begin{aligned}
 & A * [(\{B\} * \{C\}) * B] \\
 &= A * [(\{dg_1\} * \{hg_3\}) * \{dg_1\}] \\
 &= A * [\{dhg_3\} * \{dg_1\}] \\
 &= A * \{hg_3 * g_1\} \\
 &= \{ag_5\} * \{hg_1\} = \{ahg_5 * g_1\} \\
 &= \{hg_7\} \qquad \dots \qquad II
 \end{aligned}$$

We see I and II are identical so we see this set of elements satisfies the Bol identity.

Now we take  $A = \{ig_6\}$  and  $B = \{hg_1 + gg_4\} \in S$ .

We see  $A * B = \{0\}$  and  $B * A = \{0\}$ . Thus S has non trivial subset zero divisors.

Take  $A = \{hg_2\} \in S$ , we see  $A * A = A$  and  $B = \{ag_4\} \in S$  we see  $B * B = B$ .

Thus S has subset idempotents. S has nontrivial subset zero divisors.

**Example 2.8:** Let  $S = \{\text{Collection of all subsets of the groupoid ring } ZG \text{ where } G \text{ is given by the following table};$

*	$g_0$	$g_1$	$g_2$	$g_3$	$g_4$	$g_5$	$g_6$	$g_7$	$g_8$	$g_9$
$g_0$	$g_0$	$g_2$	$g_4$	$g_6$	$g_8$	$g_0$	$g_2$	$g_4$	$g_6$	$g_8$
$g_1$	$g_1$	$g_3$	$g_5$	$g_7$	$g_9$	$g_1$	$g_3$	$g_5$	$g_7$	$g_9$
$g_2$	$g_2$	$g_4$	$g_6$	$g_8$	$g_0$	$g_2$	$g_4$	$g_6$	$g_8$	$g_0$
$g_3$	$g_3$	$g_5$	$g_7$	$g_9$	$g_1$	$g_3$	$g_5$	$g_7$	$g_9$	$g_1$
$g_4$	$g_4$	$g_6$	$g_8$	$g_0$	$g_2$	$g_4$	$g_6$	$g_8$	$g_0$	$g_2$
$g_5$	$g_5$	$g_7$	$g_9$	$g_1$	$g_3$	$g_5$	$g_7$	$g_9$	$g_1$	$g_3$
$g_6$	$g_6$	$g_8$	$g_0$	$g_2$	$g_4$	$g_6$	$g_8$	$g_0$	$g_2$	$g_4$
$g_7$	$g_7$	$g_9$	$g_1$	$g_3$	$g_5$	$g_7$	$g_9$	$g_1$	$g_3$	$g_5$
$g_8$	$g_8$	$g_0$	$g_2$	$g_4$	$g_6$	$g_8$	$g_0$	$g_2$	$g_4$	$g_6$
$g_9$	$g_9$	$g_1$	$g_3$	$g_5$	$g_7$	$g_9$	$g_1$	$g_3$	$g_5$	$g_7$

be the subset semiring of the groupoid ring ZG.

Clearly S is non commutative and non associative. S has no subset zero divisors.

S has subset idempotent viz;  $A = \{g_5\}$  for  $A * A = A$ . But S is of infinite order.

In view of all these we have the following theorem.

**THEOREM 2.1:** *Let  $S = \{Collection\ of\ all\ subsets\ of\ a\ groupoid\ ring\ RG\ such\ that\ R\ is\ a\ field\ (finite\ or\ infinite)\ and\ G\ has\ no\ subset\ zero\ divisors\ but\ a\ non\ associative\ groupoid\ such\ that\  $G * G \subsetneq G$  (that is  $G * G \neq G$ ) which has no subset idempotents}$*  be the subset semiring of the groupoid ring RG. Then S is a non associative subset semiring which has no subset zero divisors and subset idempotents.

**Corollary 2.1:** Suppose in the theorem 2.1; RG has idempotents then S has subset idempotents.

The proof of both the theorem and corollary are direct and hence left as an exercise to the reader.

**Corollary 2.2:** Suppose in the theorem 2.1,  $RG$  has zero divisors then the subset semiring has subset zero divisors.

Proof follows from the simple fact that if  $x.y = 0$ ,  $x, y \in RG$  then if take  $A = \{x\}$  and  $B = \{y\}$  in  $S$  then  $A * B = \{0\}$  hence the claim.

Now we study the result when the groupoid has zero divisors then what can be said about the groupoid rings.

It is first important to keep on record that in the groupoid  $G$  in most case do not have identity that is an element  $e \in G$  such that  $eg = ge = g$  for all  $g \in G$  and  $ee = e$ . Another problem is even if  $eg = g$  with  $e^2 = e$  we may not have  $ge = g$  that is we may have only one sided identity that is right or left so when we define the notion of groupoid ring  $ZG$  we see the nature of  $Z$  is not preserved for  $Z \cong ZG$  as  $G$  has no identity. Elements in  $ZG$  are of the form  $ag$  and their sums, so  $a \in Z$  then  $a \notin ZG$  if  $a$  is different from zero. However as  $1 \in Z$  we see  $G \subseteq ZG$  as  $1.g = g$  for all  $g \in G$ .

Keeping all this in mind we work with the subset semirings of the groupoid rings.

**Example 2.9:** Let  $S = \{\text{Collection of all subsets of the groupoid ring } LG \text{ where } L \text{ is a lattice given by}$

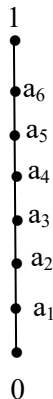





be the subset semiring of the groupoid ring;

$$Z_{11}G = \left\{ \sum_i a_i g_i \mid a_i \in Z_{11}, g_i \in G, 1 \leq i \leq 5 \right\}.$$

We see the subset semiring is non associative; has subset zero divisors and subset idempotents.

$$\begin{aligned} \text{Let } A &= \{g_2 + g_4, 5g_4 + g_2, 3g_4, 7g_2, 5g_2 + 7g_4\} \text{ and} \\ B &= \{3g_2, 5g_4 + 8g_2, 9g_4 + g_2, 10g_2 + g_4\} \in S. \end{aligned}$$

We see  $A * B = \{0\}$ . However  $B * A = \{0\}$ .

We see S has right subset zero divisors which are not left subset zero divisors as well as left subset zero divisors which are not right subset zero divisors.

Take  $A = \{0, g_2, g_4\}$  and  $B = \{3g_3, 10g_5, 2g_3 + g_5\}$  be in S.

Clearly  $A * B = \{0\}$ , however  $B * A \neq \{0\}$ .

Here we see in the groupoid ring  $Z_{11}G$ ;  $Z_{11}$  is a field however,  $Z_{11}G$  has zero divisors as G has zero divisors.

**Example 2.12:** Let us consider the  $S = \{\text{Collection of all subsets of the groupoid ring } Z_{12}G \text{ where } G = \{0, g_1, g_2, g_3, g_4, g_5\}$  is given by the following table;

*	0	$g_1$	$g_2$	$g_3$	$g_4$	$g_5$
0	0	$g_5$	$g_4$	$g_3$	$g_2$	$g_1$
$g_1$	$g_3$	$g_2$	$g_1$	0	$g_5$	$g_4$
$g_2$	0	$g_5$	$g_4$	$g_3$	$g_2$	$g_1$
$g_3$	$g_3$	$g_2$	$g_1$	0	$g_5$	$g_4$
$g_4$	0	$g_5$	$g_4$	$g_3$	$g_2$	$g_1$
$g_5$	$g_3$	$g_2$	$g_1$	0	$g_5$	$g_4$

be the subset semiring of the groupoid ring  $Z_{12}G$ .  $S$  has subset zero divisors and subset idempotents.

Take  $A = \{2g_3, 4g_3, 8g_3\}$  and  $B = \{g_3, 6g_3\} \in S$ .

We see  $A * B = \{0\}$  and  $B * A = \{0\}$ .

$A * A = \{0\}$  and  $B * B = \{0\}$ .

We see  $S$  has subset zero divisors and subset nilpotent elements.

**Example 2.13:** Let  $S = \{\text{Collection of all subsets of the groupoid ring } Z_6G \text{ where } G = \{0, g_1, g_2, g_3, \dots, g_{11}\}$  is given by the following table;

*	$g_0$	$g_1$	$g_2$	$g_3$	$g_4$	$g_5$	$g_6$	$g_7$	$g_8$	$g_9$	$g_{10}$	$g_{11}$
$g_0$	0	$g_6$	0	$g_6$	0	$g_6$	0	$g_6$	0	$g_6$	0	$g_6$
$g_1$	$g_1$	$g_7$	$g_1$	$g_7$	$g_1$	$g_7$	$g_1$	$g_7$	$g_1$	$g_7$	$g_1$	$g_7$
$g_2$	$g_2$	$g_8$	$g_2$	$g_8$	$g_2$	$g_8$	$g_2$	$g_8$	$g_2$	$g_8$	$g_2$	$g_8$
$g_3$	$g_3$	$g_9$	$g_3$	$g_9$	$g_3$	$g_9$	$g_3$	$g_9$	$g_3$	$g_9$	$g_3$	$g_9$
$g_4$	$g_4$	$g_{10}$	$g_4$	$g_{10}$	$g_4$	$g_{10}$	$g_4$	$g_{10}$	$g_4$	$g_{10}$	$g_4$	$g_{10}$
$g_5$	$g_5$	$g_{11}$	$g_5$	$g_{11}$	$g_5$	$g_{11}$	$g_5$	$g_{11}$	$g_5$	$g_{11}$	$g_5$	$g_{11}$
$g_6$	$g_6$	0	$g_6$	0	$g_6$	0	$g_6$	$g_0$	$g_6$	0	$g_6$	0
$g_7$	$g_7$	$g_1$	$g_7$	$g_1$	$g_7$	$g_1$	$g_7$	$g_1$	$g_7$	$g_1$	$g_7$	$g_1$
$g_8$	$g_8$	$g_2$	$g_8$	$g_2$	$g_8$	$g_2$	$g_8$	$g_2$	$g_8$	$g_2$	$g_8$	$g_2$
$g_9$	$g_9$	$g_3$	$g_9$	$g_3$	$g_9$	$g_3$	$g_9$	$g_3$	$g_9$	$g_3$	$g_9$	$g_3$
$g_{10}$	$g_{10}$	$g_4$	$g_{10}$	$g_4$	$g_{10}$	$g_4$	$g_{10}$	$g_4$	$g_{10}$	$g_4$	$g_{10}$	$g_4$
$g_{11}$	$g_{11}$	$g_5$	$g_{11}$	$g_5$	$g_{11}$	$g_5$	$g_{11}$	$g_5$	$g_{11}$	$g_5$	$g_{11}$	$g_5$

be the subset semigroup of the groupoid ring  $Z_6G$ .  $S$  has subset zero divisors, subset idempotents and is non associative and non commutative of finite order.

$$A = \{3g_2, g_4, g_8\} \text{ and } B = \{5g_6\} \in S.$$

We find

$$B * A = \{3g_6, 5g_6, 5g_6, 5g_6\} = \{3g_6, 5g_6\} \quad \dots \text{ I}$$

$$A * B = \{3g_2 * 5g_6, g_4 * 5g_6, 5g_8 * 5g_6\} \quad \dots \text{ II}$$

We see  $A * B \neq B * A$  as I and II are distinct. So S is a non commutative subset semiring which is non associative.

$$\text{Let } A = \{3g_1\}, B = \{5g_2 + g_3\} \text{ and } C = \{2g_4 + 8g_{10}\} \in S.$$

$$A * (B * C)$$

$$= A * (\{5g_2 + g_3\} * \{2g_4 + 8g_{10}\})$$

$$= A * \{(5g_2 + g_3) * (2g_4 + 8g_{10})\}$$

$$= A * \{10g_2 * g_4 + 2g_3 * g_4 + 40g_2 * g_{10} + 8g_3 * g_{10}\}$$

$$= A * \{4g_2 + 2g_3 + 4g_2 + 2g_3\}$$

$$= \{3g_1\} * \{2g_2 + 4g_3\}$$

$$= \{0\} \quad \dots \text{ I}$$

$$\text{Consider } (A * B) * C$$

$$= (\{3g_1\} * \{5g_2 + g_3\}) * C$$

$$= (\{3g_1\} * \{5g_2 + g_3\}) * C$$

$$= \{15g_1 * g_2 + 3g_1 * g_3\} * C$$

$$= \{3g_1 + 3g_7\} * \{2g_4 + 8g_{10}\}$$

$$= \{6g_1 * g_4 + 6g_7 * g_4 + 24g_1 * g_{10} + 24g_7 * g_{10}\}$$

$$= \{0\} \quad \dots \text{ II}$$

We see I and II are equal so for this set of A, B, C  $\in$  S we see  $A * (B * C) = (A * B) * C$ .

$$\text{Let } A = \{2g_1\}, B = \{g_3\} \text{ and } C = \{4g_4\} \in S.$$

$$\text{We find } (A * B) * C$$

$$= (\{2g_1\} * \{g_3\}) * C$$

$$= \{2g_1 * g_3\} * C$$

$$= \{2g_7\} * \{4g_4\}$$

$$\begin{aligned}
 &= \{2 \times 4g_7 * g_4\} \\
 &= \{2g_1\} \qquad \dots \qquad \text{I}
 \end{aligned}$$

Now we find  $A * (B * C)$ ;

$$\begin{aligned}
 &= A * (B * C) \\
 &= A * (\{g_3\} * \{4g_4\}) \\
 &= A * \{4g_3 * g_4\} = \{2g_1\} * \{4g_3\} \\
 &= \{2g_1 * g_3\} \\
 &= \{2g_7\} \qquad \dots \qquad \text{II}
 \end{aligned}$$

For this triple  
 $(A * B) * C \neq A * (B * C)$  as I and II are distinct.  
 We can find many  $A, B, C \in S$  with  
 $(A * B) * C \neq A * (B * C)$ .

**Example 2.14:** Let  $S = \{\text{Collection of all subsets of the groupoid ring } RG \text{ where } G \text{ is the groupoid given by the following table};$

*	0	$g_1$	$g_2$	$g_3$	$g_4$	$g_5$	$g_6$	$g_7$	$g_8$
0	0	$g_4$	$g_8$	$g_3$	$g_7$	$g_2$	$g_6$	$g_1$	$g_5$
$g_1$	$g_4$	$g_8$	$g_3$	$g_7$	$g_2$	$g_6$	$g_1$	$g_5$	0
$g_2$	$g_8$	$g_3$	$g_7$	$g_2$	$g_6$	$g_1$	$g_5$	0	$g_4$
$g_3$	$g_3$	$g_7$	$g_2$	$g_6$	$g_1$	$g_5$	0	$g_4$	$g_8$
$g_4$	$g_7$	$g_2$	$g_6$	$g_1$	$g_5$	0	$g_4$	$g_8$	$g_3$
$g_5$	$g_2$	$g_6$	$g_1$	$g_5$	0	$g_4$	$g_8$	$g_3$	$g_7$
$g_6$	$g_6$	$g_1$	$g_5$	0	$g_4$	$g_8$	$g_3$	$g_7$	$g_2$
$g_7$	$g_1$	$g_5$	0	$g_4$	$g_8$	$g_3$	$g_7$	$g_2$	$g_6$
$g_8$	$g_5$	0	$g_4$	$g_8$	$g_3$	$g_7$	$g_2$	$g_6$	$g_1$

be the subset semiring of the groupoid  $RG$ .

We know  $RG$  is of infinite order but non associative.

However  $RG$  is a commutative subset semiring which is non associative.

We have subset idempotents and subset zero divisors in S.

We can have substructures for these subset semirings as subset subsemirings and subset ideals of subset semiring. Let S be a subset semiring we call  $P \subseteq S$  to be a subset subsemiring if P itself is a subset semiring under the operations of S.

We call P to be a subset ideal if for all  $p \in P$  and  $s \in S$ ;  $p * s$  and  $s * p \in P$ .

If one of  $p * s$  or  $s * p$  alone is in P we see P is only a right or left ideal and not an ideal.

We now give examples of substructures of subset semirings.

**Example 2.15:** Let  $S = \{\text{Collection of all subsets of the groupoid ring } Z_8G \text{ where } G \text{ is the groupoid given by the following table;}$

*	0	g <sub>1</sub>	g <sub>2</sub>	g <sub>3</sub>	g <sub>4</sub>	g <sub>5</sub>	g <sub>6</sub>	g <sub>7</sub>	g <sub>8</sub>	g <sub>9</sub>	g <sub>10</sub>	g <sub>11</sub>
0	0	g <sub>3</sub>	g <sub>6</sub>	g <sub>9</sub>	0	g <sub>3</sub>	g <sub>6</sub>	g <sub>9</sub>	0	g <sub>3</sub>	g <sub>6</sub>	g <sub>9</sub>
g <sub>1</sub>	g <sub>1</sub>	g <sub>4</sub>	g <sub>7</sub>	g <sub>10</sub>	g <sub>1</sub>	g <sub>4</sub>	g <sub>7</sub>	g <sub>10</sub>	g <sub>1</sub>	g <sub>4</sub>	g <sub>7</sub>	g <sub>10</sub>
g <sub>2</sub>	g <sub>2</sub>	g <sub>5</sub>	g <sub>8</sub>	g <sub>11</sub>	g <sub>2</sub>	g <sub>5</sub>	g <sub>8</sub>	g <sub>11</sub>	g <sub>2</sub>	g <sub>5</sub>	g <sub>8</sub>	g <sub>11</sub>
g <sub>3</sub>	g <sub>3</sub>	g <sub>6</sub>	g <sub>9</sub>	0	g <sub>3</sub>	g <sub>6</sub>	g <sub>9</sub>	0	g <sub>3</sub>	g <sub>6</sub>	g <sub>9</sub>	0
g <sub>4</sub>	g <sub>4</sub>	g <sub>7</sub>	g <sub>10</sub>	g <sub>1</sub>	g <sub>4</sub>	g <sub>7</sub>	g <sub>10</sub>	g <sub>1</sub>	g <sub>4</sub>	g <sub>7</sub>	g <sub>10</sub>	g <sub>1</sub>
g <sub>5</sub>	g <sub>5</sub>	g <sub>8</sub>	g <sub>11</sub>	g <sub>2</sub>	g <sub>5</sub>	g <sub>8</sub>	g <sub>11</sub>	g <sub>2</sub>	g <sub>5</sub>	g <sub>8</sub>	g <sub>11</sub>	g <sub>2</sub>
g <sub>6</sub>	g <sub>6</sub>	g <sub>9</sub>	0	g <sub>3</sub>	g <sub>6</sub>	g <sub>9</sub>	0	g <sub>3</sub>	g <sub>6</sub>	g <sub>9</sub>	0	g <sub>3</sub>
g <sub>7</sub>	g <sub>7</sub>	g <sub>10</sub>	g <sub>1</sub>	g <sub>4</sub>	g <sub>7</sub>	g <sub>10</sub>	g <sub>1</sub>	g <sub>4</sub>	g <sub>7</sub>	g <sub>10</sub>	g <sub>1</sub>	g <sub>4</sub>
g <sub>8</sub>	g <sub>8</sub>	g <sub>11</sub>	g <sub>2</sub>	g <sub>5</sub>	g <sub>8</sub>	g <sub>11</sub>	g <sub>2</sub>	g <sub>5</sub>	g <sub>8</sub>	g <sub>11</sub>	g <sub>2</sub>	g <sub>5</sub>
g <sub>9</sub>	g <sub>9</sub>	0	g <sub>3</sub>	g <sub>6</sub>	g <sub>9</sub>	0	g <sub>3</sub>	g <sub>6</sub>	g <sub>9</sub>	0	g <sub>3</sub>	g <sub>6</sub>
g <sub>10</sub>	g <sub>10</sub>	g <sub>1</sub>	g <sub>4</sub>	g <sub>7</sub>	g <sub>10</sub>	g <sub>1</sub>	g <sub>4</sub>	g <sub>7</sub>	g <sub>10</sub>	g <sub>1</sub>	g <sub>10</sub>	g <sub>7</sub>
g <sub>11</sub>	g <sub>11</sub>	g <sub>2</sub>	g <sub>5</sub>	g <sub>8</sub>	g <sub>11</sub>	g <sub>2</sub>	g <sub>5</sub>	g <sub>8</sub>	g <sub>11</sub>	g <sub>2</sub>	g <sub>1</sub>	g <sub>8</sub>

be the subset semiring of the groupoid ring  $Z_8G$ .

Let  $P_1 = \{\text{Collection of all subsets of the subgroupoid } \{0, g_3, g_6, g_9\}\} \subseteq S$ .  $P_1$  is a subset subsemiring of  $S$ .

Clearly  $P_1$  is not a subset semiring ideal of  $S$  only a subset subsemiring of  $S$ .

Take  $P_2 = \{\text{Collection of all subsets of the set } \{2, 5, 8, 11\} \subseteq G\} \subseteq S$ ;  $P_2$  is a subset subsemiring of the subset semiring. Clearly  $P_2$  is a subset ideal of the semiring  $S$ . Infact both  $P_1$  and  $P_2$  are one sided subset ideals and not two sided subset ideals.

**Example 2.16:** Let  $S = \{\text{Collection of all subsets of the lattice groupoid } LG \text{ where } L \text{ is a lattice}\}$

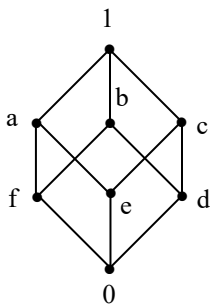

and the groupoid  $G$  is as follows:

*	0	$g_1$	$g_2$	$g_3$	$g_4$	$g_5$	$g_6$	$g_7$
0	0	$g_6$	$g_4$	$g_2$	0	$g_6$	$g_4$	$g_2$
$g_1$	$g_2$	0	$g_6$	$g_4$	$g_2$	0	$g_6$	$g_2$
$g_2$	$g_4$	$g_2$	0	$g_6$	$g_4$	$g_2$	0	$g_6$
$g_3$	$g_6$	$g_4$	$g_2$	0	$g_6$	$g_4$	$g_2$	0
$g_4$	0	$g_6$	$g_4$	$g_2$	0	$g_6$	$g_4$	$g_2$
$g_5$	$g_2$	0	$g_6$	$g_4$	$g_2$	0	$g_6$	$g_4$
$g_6$	$g_4$	$g_2$	0	$g_6$	$g_4$	$g_2$	0	$g_6$
$g_7$	$g_6$	$g_4$	$g_2$	0	$g_6$	$g_4$	$g_2$	0

be the subset semiring of the lattice groupoid  $LG$ .  $S$  has subset zero divisors.

Take  $P_1 = \{\text{Collection of all subsets of the set } LT \text{ where } T = \{0, 2, 4, 6\} \subseteq G\} \subseteq S$ .

We see  $P_1$  is a subset subsemiring of  $S$ ;  $P_1$  is also a subset semiring ideal of  $S$ . So  $P_1$  is both a subset subsemiring as well as subset semiring ideal of  $S$ .

In view of all these we have the following theorem.

**THEOREM 2.2:** *Let  $S = \{\text{Collection of all subsets of a groupoid ring or groupoid semiring}\}$  be the subset non associative semiring of the groupoid ring  $ZG$  or groupoid semiring  $ZG$ .*

*Let  $P_1 \subseteq S$  be a subset semiring ideal of  $S$  then  $P_1$  is a subset subsemiring of the subset semiring  $S$ . However if  $P_1$  is a subset subsemiring then  $P_1$  in general need not be a subset semiring ideal of  $S$ .*

The proof is direct hence left as an exercise to the reader.

Also the examples given substantiate the claims of the theorem.

We see if the groupoid ring  $RG$  is such that  $G$  is a Smarandache groupoid then we define  $S$  to be a semi Smarandache subset non associative semiring of the Smarandache groupoid ring.

However if the subset non associative semiring  $S$  is to be a Smarandache subset non associative ring then  $S$  must contain a proper subset which is a subset associative semiring.

In fact  $S$  is a Smarandache strong subset non associative semiring if  $S$  contains a proper subset  $P \subset S$  which is an associative ring.

We will first illustrate this situation by some examples.



**Example 2.17:** Let  $S = \{\text{Collection of all subsets of the groupoid ring } ZG \text{ where the table of } G \text{ is given in the following;}$

*	0	1	2	3	4	5
0	0	3	0	3	0	3
1	1	4	1	4	1	4
2	2	5	2	5	2	5
3	3	0	3	0	3	0
4	4	1	4	1	4	1
5	5	2	5	2	5	2

be the subset non associative semiring of the groupoid ring  $ZG$ .

We see  $S$  is a Smarandache strong subset non associative semiring as  $S$  contains  $P$  where  $P$  is a subset associative ring.

Take  $P = \{\{a_i\} \mid \{a_i\} \in \{\text{singleton sets of the semigroup ring } ZM \text{ where } M = \{1, 4\} \subseteq G, \text{ is a semigroup of the groupoid } G \text{ that is } G \text{ is a Smarandache groupoid}\}\}$ .

Clearly  $P$  is a subset associative ring in  $S$ . Hence  $S$  is a Smarandache strong subset non associative semiring of the groupoid ring  $ZG$ .

Further if we take  $N = \{2, 5\} \subseteq G$  then  $ZN$  is an associative ring (semigroup ring) contained in  $ZG$ ; further if  $B = \{\text{Collection of all subsets of the ring } ZN\}$  and  $W = \{\{a_i\} \mid a_i \in ZN\}$  then  $W$  is a subset associative ring isomorphic to  $ZN$  by a isomorphism  $\eta(\{a_i\}) = a_i$  for  $a_i \in ZN$  and  $\{a_i\} \in W$ . So  $W \cong ZN$ .

Hence  $S$  is a Smarandache strong subset nonassociative semiring of  $ZG$ .

**Example 2.18:** Let  $S = \{\text{Collection of all subsets of the groupoid semiring } (Z^+ \cup \{0\})G \text{ where } G \text{ is the groupoid given by the following table:}$

*	0	1	2	3	4
0	0	4	3	2	1
1	2	1	0	4	3
2	4	3	2	1	0
3	1	0	4	3	2
4	3	2	1	0	4

be the subset non associative semiring.

Take  $(Z^+ \cup \{0\}) (g)$  where  $g = 4 \in G$  is a semigroup in the groupoid  $G$ . We see  $(Z^+ \cup \{0\})g = \{ag \mid a \in Z^+ \cup \{0\}\}$  is a semifield isomorphic with  $Z^+ \cup \{0\}$ .

Thus  $S$  is a Smarandache subset non associative semiring as  $S$  contains subset  $B \subseteq P = \{\text{subsets of the semifield } (Z^+ \cup \{0\})g\}$  where  $B = \{\{ag \mid ag \in P\}$  is a semifield isomorphic with  $Z^+ \cup \{0\}$  by an isomorphism  $\{ag\} \mapsto a$  for every  $a \in Z^+ \cup \{0\}$ ; so that  $B \cong Z^+ \cup \{0\}$ .

**Example 2.19:** Let  $S = \{\text{Collection of all subsets of the groupoid lattice } LG \text{ where the lattice } L \text{ is given by } L =$

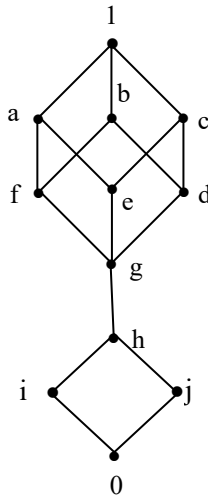

and G is a given by the following table;

*	0	1	2	3	4	5	6	7	8	9
0	0	5	0	5	0	5	0	5	0	5
1	1	6	1	6	1	6	1	6	1	6
2	2	7	2	7	2	7	2	7	2	7
3	3	8	3	8	3	8	3	8	3	8
4	4	9	4	9	4	9	4	9	4	9
5	5	0	5	0	5	0	5	0	5	0
6	6	1	6	1	6	1	6	1	6	1
7	7	2	7	2	7	2	7	2	7	2
8	8	3	8	3	8	3	8	3	8	3
9	9	4	9	4	9	4	9	4	9	4

be the subset non associative semiring of finite order.

Take  $P = \{0, 5\} \subseteq G$  which is a semigroup in G. Consider TP; Take  $M = \{\text{Collection of all subsets of the semigroup lattice TP where } P = \{0, 5\} \text{ and } T =$

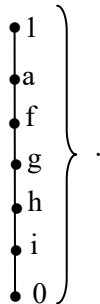

Let  $B = \{\{a_i\} \in M\} \subseteq S$ ; B is a subset semiring not a Smarandache subset semiring.

If we take  $\{6\} \in G$ ; then

$$W = \{\{a_i g\} \mid g = 6 \text{ and } a_i \in T\} \subseteq S \text{ and}$$

$W$  is a semifield so  $S$  is a Smarandache subset non associative semiring.

**Example 2.20:** Let  $S = \{\text{Collection of all subsets of the groupoid ring } Z_7G \text{ where } G \text{ is a groupoid given by the following table};$

*	0	1	2	3	4	5	6	7
0	0	6	4	2	0	6	4	2
1	1	7	5	3	1	7	5	3
2	2	0	6	4	2	0	6	4
3	3	1	7	5	3	1	7	5
4	4	2	0	6	4	2	0	6
5	5	3	1	7	5	3	1	7
6	6	4	2	0	6	4	2	0
7	7	5	3	1	7	5	3	1

be the subset non associative semiring of the groupoid ring  $Z_7G$ .

$A = \{4\} \subseteq G$  and  $B = \{1, 7\} \subseteq G$  are semigroups of  $(G, *)$ . Let  $M = \{\text{Collection of all subsets of the semigroup ring } Z_7A \text{ (or } Z_7B)\} \subseteq S$ ;  $P = \{\{ag\} \mid a \in Z_7 \text{ and } g \in A\} \subseteq S$ .  $P$  is a subset ring.

Thus  $S$  is a Smarandache strong subset non associative semiring.  $W = \{\{ag\} \mid a \in Z_7 \text{ and } g \in B\} \subseteq S$  is a subset associative ring.

**Example 2.21:** Let  $S = \{\text{Collection of all subsets of the groupoid ring } Z_2G \text{ where } G \text{ is a groupoid given by the following table};$

*	1	a <sub>1</sub>	a <sub>2</sub>	a <sub>3</sub>	a <sub>4</sub>
1	1	a <sub>1</sub>	a <sub>2</sub>	a <sub>3</sub>	a <sub>4</sub>
a <sub>1</sub>	a <sub>1</sub>	1	a <sub>3</sub>	a <sub>2</sub>	a <sub>1</sub>
a <sub>2</sub>	a <sub>2</sub>	a <sub>1</sub>	1	a <sub>3</sub>	a <sub>2</sub>
a <sub>3</sub>	a <sub>3</sub>	a <sub>2</sub>	a <sub>1</sub>	1	a <sub>3</sub>
a <sub>4</sub>	a <sub>4</sub>	a <sub>3</sub>	a <sub>2</sub>	a <sub>1</sub>	1

be the subset non associative semiring of the groupoid ring  $Z_2G$ .

$G$  is a Smarandache groupoid as  $\{1, a_i\} = P_i$  are semigroups;  $1 \leq i \leq 4$ .

Let

$B_i = \{\text{Collection of all subsets of the semigroup ring } Z_2P_i\}$   
 be the subset associative semiring for  $1 \leq i \leq 4$ .

Thus  $S$  is a Smarandache subset non associative semiring.

**Example 2.22:** Let  $S = \{\text{Collection of all subsets of the groupoid ring } Z_{12}G \text{ where } G \text{ is the groupoid given by the following table;}$

*	e	g <sub>1</sub>	g <sub>2</sub>	g <sub>3</sub>	g <sub>4</sub>	g <sub>5</sub>	g <sub>6</sub>	g <sub>7</sub>
e	e	g <sub>1</sub>	g <sub>2</sub>	g <sub>3</sub>	g <sub>4</sub>	g <sub>5</sub>	g <sub>6</sub>	g <sub>7</sub>
g <sub>1</sub>	g <sub>1</sub>	e	g <sub>5</sub>	g <sub>2</sub>	g <sub>6</sub>	g <sub>3</sub>	g <sub>7</sub>	g <sub>4</sub>
g <sub>2</sub>	g <sub>2</sub>	g <sub>5</sub>	e	g <sub>6</sub>	g <sub>3</sub>	g <sub>7</sub>	g <sub>4</sub>	g <sub>1</sub>
g <sub>3</sub>	g <sub>3</sub>	g <sub>2</sub>	g <sub>6</sub>	e	g <sub>7</sub>	g <sub>4</sub>	g <sub>1</sub>	g <sub>5</sub>
g <sub>4</sub>	g <sub>4</sub>	g <sub>6</sub>	g <sub>3</sub>	g <sub>7</sub>	e	g <sub>1</sub>	g <sub>5</sub>	g <sub>2</sub>
g <sub>5</sub>	g <sub>5</sub>	g <sub>3</sub>	g <sub>7</sub>	g <sub>4</sub>	g <sub>1</sub>	e	g <sub>2</sub>	g <sub>6</sub>
g <sub>6</sub>	g <sub>6</sub>	g <sub>7</sub>	g <sub>4</sub>	g <sub>1</sub>	g <sub>5</sub>	g <sub>2</sub>	e	g <sub>3</sub>
g <sub>7</sub>	g <sub>7</sub>	g <sub>4</sub>	g <sub>1</sub>	g <sub>5</sub>	g <sub>2</sub>	g <sub>6</sub>	g <sub>3</sub>	e

be the subset non associative semiring of the groupoid ring  $Z_{12}G$ .

$G$  is a Smarandache groupoid with  $e$  as its identity. Further we see  $S$  is a Smarandache subset non associative semiring.

We can define the notion of Smarandache subset non associative subsemiring and Smarandache subset non associative semiring ideal as in case of usual non associative semirings. We see the subset non associative semiring given in example 2.22 is commutative.

In view of all these examples we have the following theorems.

**THEOREM 2.3:** *Let  $S = \{ \text{Collection of all subsets of the groupoid ring } RG \text{ where } R \text{ is a ring and } G \text{ a groupoid} \}$  be the subset non associative semiring of the groupoid ring  $RG$ .*

*If  $G$  is a Smarandache groupoid then  $S$  is a Smarandache strong subset non associative semiring and conversely if  $S$  is a Smarandache strong subset non associative semiring then  $G$  is a Smarandache groupoid.*

Proof is direct and hence left as an exercise to the reader.

**THEOREM 2.4:** *Let*

*$S = \{ \text{Collection of all subsets of the groupoid semiring } PG \}$  be the subset non associative semiring of the groupoid semiring  $PG$ .  $S$  is a Smarandache subset non associative semiring if  $G$  has subset  $T$  such that  $T$  is a semigroup, then  $PT$  is a subset associative semiring and conversely if  $S$  is a Smarandache subset non associative semiring then  $G$  is a Smarandache groupoid if  $G$  has no identity.*

Proof is direct and hence is left as an exercise to the reader.

Let  $S$  be a subset non associative semiring we call a subset subring  $V$  of  $S$  to be a normal subset subring if

- (i)  $aV = Va$
- (ii)  $(Vx)y = V(xy)$
- (iii)  $y(xV) = (yx)V$  for all  $x, y, a \in V$ .

The subset non associative semiring is simple if it has no subset normal subrings.

The subset non associative semiring  $S$  is normal, if

- (i)  $xS = Sx$
- (ii)  $S(xy) = (Sx)y$
- (iii)  $y(xS) = (yx)S$  for all  $x, y \in S$ .

We define for the subset non associative semiring  $S$  the notion of centre.

Centre of  $S$ ,  $C(S) = \{x \in S \mid xa = ax \text{ for all } a \in S\}$ .

We give some examples of them.

**Example 2.23:** Let  $S = \{\text{Collection of all subsets of the groupoid ring } Z_{11}G \text{ where } G \text{ is the groupoid given by the following table;}$

*	$a_0$	$a_1$	$a_2$	$a_3$	$a_4$	$a_5$	$a_6$
$a_0$	$a_0$	$a_4$	$a_1$	$a_5$	$a_2$	$a_6$	$a_3$
$a_1$	$a_3$	$a_0$	$a_4$	$a_1$	$a_5$	$a_2$	$a_6$
$a_2$	$a_6$	$a_3$	$a_0$	$a_4$	$a_1$	$a_5$	$a_2$
$a_3$	$a_2$	$a_6$	$a_3$	$a_0$	$a_4$	$a_1$	$a_5$
$a_4$	$a_5$	$a_2$	$a_6$	$a_3$	$a_0$	$a_4$	$a_1$
$a_5$	$a_1$	$a_5$	$a_2$	$a_6$	$a_3$	$a_0$	$a_4$
$a_6$	$a_4$	$a_1$	$a_5$	$a_2$	$a_3$	$a_3$	$a_0$

be the subset non associative semiring of finite order.

We see  $G$  is a normal groupoid. If  $G$  is a normal groupoid then we define  $S$  to be a normal subset non associative semiring. Thus  $S$  in example 2.23 is normal subset non associative semiring.

**Example 2.24:** Let  $S = \{\text{Collection of all subsets of the groupoid ring } Z_2G \text{ where } G \text{ is given by the following table;}$

*	$a_0$	$a_1$	$a_2$	$a_3$	$a_4$	$a_5$	$a_6$	$a_7$	$a_8$	$a_9$
$a_0$	$a_0$	$a_2$	$a_4$	$a_0$	$a_8$	$a_0$	$a_2$	$a_4$	$a_6$	$a_8$
$a_1$	$a_1$	$a_3$	$a_5$	$a_1$	$a_9$	$a_1$	$a_3$	$a_5$	$a_7$	$a_9$
$a_2$	$a_2$	$a_4$	$a_6$	$a_2$	$a_0$	$a_2$	$a_4$	$a_6$	$a_8$	$a_0$
$a_3$	$a_3$	$a_5$	$a_7$	$a_3$	$a_1$	$a_3$	$a_5$	$a_7$	$a_9$	$a_1$
$a_4$	$a_4$	$a_6$	$a_8$	$a_4$	$a_2$	$a_4$	$a_6$	$a_8$	$a_0$	$a_2$
$a_5$	$a_5$	$a_7$	$a_9$	$a_5$	$a_3$	$a_5$	$a_7$	$a_9$	$a_1$	$a_3$
$a_6$	$a_6$	$a_8$	$a_0$	$a_6$	$a_4$	$a_6$	$a_8$	$a_0$	$a_2$	$a_4$
$a_7$	$a_7$	$a_9$	$a_1$	$a_7$	$a_5$	$a_7$	$a_9$	$a_1$	$a_3$	$a_5$
$a_8$	$a_8$	$a_0$	$a_2$	$a_8$	$a_6$	$a_8$	$a_0$	$a_2$	$a_4$	$a_6$
$a_9$	$a_9$	$a_1$	$a_3$	$a_9$	$a_7$	$a_9$	$a_1$	$a_3$	$a_5$	$a_7$

be the subset non associative semiring of the groupoid ring  $Z_2G$ . We see  $G$  is not a normal groupoid.

Thus the subset non associative semiring  $S$  is not a subset normal non associative semiring.

Now we can define conjugate subset non associative subsemirings of a subset non associative semiring of a groupoid ring (groupoid semiring).

We will first illustrate this situation by some examples.

**Example 2.25:** Let  $S = \{\text{Collection of all subsets of the groupoid ring } Z_4G \text{ where } G \text{ is given by the following table;}$



*	a <sub>0</sub>	a <sub>1</sub>	a <sub>2</sub>	a <sub>3</sub>	a <sub>4</sub>	a <sub>5</sub>	a <sub>6</sub>	a <sub>7</sub>	a <sub>8</sub>	a <sub>9</sub>	a <sub>10</sub>	a <sub>11</sub>
a <sub>0</sub>	a <sub>0</sub>	a <sub>3</sub>	a <sub>6</sub>	a <sub>9</sub>	a <sub>0</sub>	a <sub>3</sub>	a <sub>6</sub>	a <sub>9</sub>	a <sub>0</sub>	a <sub>3</sub>	a <sub>6</sub>	a <sub>9</sub>
a <sub>1</sub>	a <sub>1</sub>	a <sub>4</sub>	a <sub>7</sub>	a <sub>10</sub>	a <sub>1</sub>	a <sub>4</sub>	a <sub>7</sub>	a <sub>10</sub>	a <sub>1</sub>	a <sub>4</sub>	a <sub>7</sub>	a <sub>10</sub>
a <sub>2</sub>	a <sub>2</sub>	a <sub>5</sub>	a <sub>8</sub>	a <sub>11</sub>	a <sub>2</sub>	a <sub>5</sub>	a <sub>8</sub>	a <sub>11</sub>	a <sub>2</sub>	a <sub>5</sub>	a <sub>8</sub>	a <sub>11</sub>
a <sub>3</sub>	a <sub>3</sub>	a <sub>6</sub>	a <sub>9</sub>	a <sub>0</sub>	a <sub>3</sub>	a <sub>6</sub>	a <sub>9</sub>	a <sub>0</sub>	a <sub>3</sub>	a <sub>6</sub>	a <sub>9</sub>	a <sub>0</sub>
a <sub>4</sub>	a <sub>4</sub>	a <sub>7</sub>	a <sub>10</sub>	a <sub>1</sub>	a <sub>4</sub>	a <sub>7</sub>	a <sub>10</sub>	a <sub>1</sub>	a <sub>4</sub>	a <sub>7</sub>	a <sub>10</sub>	a <sub>1</sub>
a <sub>5</sub>	a <sub>5</sub>	a <sub>8</sub>	a <sub>11</sub>	a <sub>2</sub>	a <sub>5</sub>	a <sub>8</sub>	a <sub>11</sub>	a <sub>2</sub>	a <sub>5</sub>	a <sub>8</sub>	a <sub>11</sub>	a <sub>2</sub>
a <sub>6</sub>	a <sub>6</sub>	a <sub>9</sub>	a <sub>0</sub>	a <sub>3</sub>	a <sub>6</sub>	a <sub>9</sub>	a <sub>0</sub>	a <sub>3</sub>	a <sub>6</sub>	a <sub>9</sub>	a <sub>0</sub>	a <sub>3</sub>
a <sub>7</sub>	a <sub>7</sub>	a <sub>10</sub>	a <sub>1</sub>	a <sub>4</sub>	a <sub>7</sub>	a <sub>10</sub>	a <sub>1</sub>	a <sub>4</sub>	a <sub>7</sub>	a <sub>10</sub>	a <sub>1</sub>	a <sub>4</sub>
a <sub>8</sub>	a <sub>8</sub>	a <sub>11</sub>	a <sub>2</sub>	a <sub>5</sub>	a <sub>8</sub>	a <sub>11</sub>	a <sub>2</sub>	a <sub>5</sub>	a <sub>8</sub>	a <sub>11</sub>	a <sub>2</sub>	a <sub>5</sub>
a <sub>9</sub>	a <sub>9</sub>	a <sub>0</sub>	a <sub>3</sub>	a <sub>6</sub>	a <sub>9</sub>	a <sub>0</sub>	a <sub>3</sub>	a <sub>6</sub>	a <sub>9</sub>	a <sub>0</sub>	a <sub>3</sub>	a <sub>6</sub>
a <sub>10</sub>	a <sub>10</sub>	a <sub>1</sub>	a <sub>4</sub>	a <sub>7</sub>	a <sub>10</sub>	a <sub>1</sub>	a <sub>4</sub>	a <sub>7</sub>	a <sub>10</sub>	a <sub>1</sub>	a <sub>4</sub>	a <sub>7</sub>
a <sub>11</sub>	a <sub>11</sub>	a <sub>2</sub>	a <sub>5</sub>	a <sub>8</sub>	a <sub>11</sub>	a <sub>2</sub>	a <sub>5</sub>	a <sub>8</sub>	a <sub>11</sub>	a <sub>2</sub>	a <sub>5</sub>	a <sub>8</sub>

be the subset non associative semiring of the groupoid ring  $Z_4G$ .

Take  $M_1 = \{\text{Collection of all subsets of the subgroupoid ring } Z_4K \text{ where } K = \{a_0, a_3, a_6, a_9\} \subseteq G\} \subseteq S$  be the subset non associative subsemiring of  $S$ .

Let  $M_2 = \{\text{Collecton of all subsets of the subgroupoid ring } Z_4H \text{ where } H = \{a_2, a_5, a_8, a_{11}\} \subseteq G \text{ be the subgroupoid of } G\} \subseteq S$  be the subset non associative subsemiring of  $S$ .

We see  $M_1$  and  $M_2$  are conjugate subset non associative subsemirings of  $S$ .

For  $M_1 = xM_2$  or  $M_2x$  and  $M_1 \cap M_2 = \emptyset$  for some  $x \in M$ .

Thus we have the concept of conjugate subset non associative subsemirings.

We now as in case of any other non associative structure define in case of non associative subset semirings the notion of inner commutative.

We have seen examples of commutative subset non associative semiring.

**Example 2.26:** Let  $S = \{\text{Collection of all subsets of the groupoid ring } Z_{11}G \text{ where } G \text{ is given by the following table;}$

*	0	1	2	3	4
0	0	3	1	4	2
1	3	1	4	2	0
2	1	4	2	0	3
3	4	2	0	3	1
4	2	0	3	1	4

be the subset non associative semiring of finite order of the groupoid ring  $Z_{11}G$ .

Clearly  $SG$  is a commutative non associative subset semiring.

Now we see as in case of a non associative subset semiring  $S$  we define  $S$  to be inner commutative if  $S$  has atleast two commutative subset non associative subsemirings.

If it has only one commutative subset subsemiring then we call  $S$  to be weakly inner commutative.

We will give examples of this concept and discuss their related properties.

**Example 2.27:** Let  $S = \{\text{Collection of all subsets of the groupoid ring } ZG \text{ where } G \text{ is given by the following table;}$

*	a <sub>0</sub>	a <sub>1</sub>	a <sub>2</sub>	a <sub>3</sub>	a <sub>4</sub>	a <sub>5</sub>	a <sub>6</sub>	a <sub>7</sub>	a <sub>8</sub>	a <sub>9</sub>	a <sub>10</sub>	a <sub>11</sub>
a <sub>0</sub>	a <sub>0</sub>	a <sub>3</sub>	a <sub>6</sub>	a <sub>9</sub>	a <sub>0</sub>	a <sub>3</sub>	a <sub>6</sub>	a <sub>9</sub>	a <sub>0</sub>	a <sub>3</sub>	a <sub>6</sub>	a <sub>9</sub>
a <sub>1</sub>	a <sub>1</sub>	a <sub>4</sub>	a <sub>7</sub>	a <sub>10</sub>	a <sub>1</sub>	a <sub>4</sub>	a <sub>7</sub>	a <sub>10</sub>	a <sub>1</sub>	a <sub>4</sub>	a <sub>7</sub>	a <sub>10</sub>
a <sub>2</sub>	a <sub>2</sub>	a <sub>5</sub>	a <sub>8</sub>	a <sub>11</sub>	a <sub>2</sub>	a <sub>5</sub>	a <sub>8</sub>	a <sub>11</sub>	a <sub>2</sub>	a <sub>5</sub>	a <sub>8</sub>	a <sub>11</sub>
a <sub>3</sub>	a <sub>3</sub>	a <sub>6</sub>	a <sub>9</sub>	a <sub>0</sub>	a <sub>3</sub>	a <sub>6</sub>	a <sub>9</sub>	a <sub>0</sub>	a <sub>3</sub>	a <sub>6</sub>	a <sub>9</sub>	a <sub>0</sub>
a <sub>4</sub>	a <sub>4</sub>	a <sub>7</sub>	a <sub>10</sub>	a <sub>1</sub>	a <sub>4</sub>	a <sub>7</sub>	a <sub>10</sub>	a <sub>1</sub>	a <sub>4</sub>	a <sub>7</sub>	a <sub>10</sub>	a <sub>1</sub>
a <sub>5</sub>	a <sub>5</sub>	a <sub>8</sub>	a <sub>11</sub>	a <sub>2</sub>	a <sub>5</sub>	a <sub>8</sub>	a <sub>11</sub>	a <sub>2</sub>	a <sub>5</sub>	a <sub>8</sub>	a <sub>11</sub>	a <sub>2</sub>
a <sub>6</sub>	a <sub>6</sub>	a <sub>9</sub>	a <sub>0</sub>	a <sub>3</sub>	a <sub>6</sub>	a <sub>9</sub>	a <sub>0</sub>	a <sub>3</sub>	a <sub>6</sub>	a <sub>9</sub>	a <sub>0</sub>	a <sub>3</sub>
a <sub>7</sub>	a <sub>7</sub>	a <sub>10</sub>	a <sub>1</sub>	a <sub>4</sub>	a <sub>7</sub>	a <sub>10</sub>	a <sub>1</sub>	a <sub>4</sub>	a <sub>7</sub>	a <sub>10</sub>	a <sub>1</sub>	a <sub>4</sub>
a <sub>8</sub>	a <sub>8</sub>	a <sub>11</sub>	a <sub>2</sub>	a <sub>5</sub>	a <sub>8</sub>	a <sub>11</sub>	a <sub>2</sub>	a <sub>5</sub>	a <sub>8</sub>	a <sub>11</sub>	a <sub>2</sub>	a <sub>5</sub>
a <sub>9</sub>	a <sub>9</sub>	a <sub>0</sub>	a <sub>3</sub>	a <sub>6</sub>	a <sub>9</sub>	a <sub>0</sub>	a <sub>3</sub>	a <sub>6</sub>	a <sub>9</sub>	a <sub>0</sub>	a <sub>3</sub>	a <sub>6</sub>
a <sub>10</sub>	a <sub>10</sub>	a <sub>1</sub>	a <sub>4</sub>	a <sub>7</sub>	a <sub>10</sub>	a <sub>1</sub>	a <sub>4</sub>	a <sub>7</sub>	a <sub>10</sub>	a <sub>1</sub>	a <sub>4</sub>	a <sub>7</sub>
a <sub>11</sub>	a <sub>11</sub>	a <sub>2</sub>	a <sub>5</sub>	a <sub>8</sub>	a <sub>11</sub>	a <sub>2</sub>	a <sub>5</sub>	a <sub>8</sub>	a <sub>11</sub>	a <sub>2</sub>	a <sub>5</sub>	a <sub>8</sub>

be the subset non associative semiring.

This S is not commutative has subset non associative and non commutative subsemirings.

Let  $S_1 = \{\text{Collection of all subsets of the subgroupoid ring } ZH_1 \text{ where } H_1 = \{a_0, a_3, a_6, a_9\} \subseteq G \text{ given by the table;}$

*	a <sub>0</sub>	a <sub>3</sub>	a <sub>6</sub>	a <sub>9</sub>
a <sub>0</sub>	a <sub>0</sub>	a <sub>9</sub>	a <sub>6</sub>	a <sub>3</sub>
a <sub>3</sub>	a <sub>3</sub>	a <sub>0</sub>	a <sub>9</sub>	a <sub>6</sub>
a <sub>6</sub>	a <sub>6</sub>	a <sub>3</sub>	a <sub>0</sub>	a <sub>9</sub>
a <sub>9</sub>	a <sub>9</sub>	a <sub>6</sub>	a <sub>3</sub>	a <sub>0</sub>

be the subset non associative and non commutative subsemiring of S.

$S_2 = \{\text{Collection of all subsets of the subgroupoid ring } ZH_2 \text{ where } H_2 = \{a_2, a_5, a_8, a_{11}\} \text{ is given by the following table;}$

*	a <sub>2</sub>	a <sub>5</sub>	a <sub>8</sub>	a <sub>11</sub>
a <sub>2</sub>	a <sub>8</sub>	a <sub>5</sub>	a <sub>2</sub>	a <sub>11</sub>
a <sub>5</sub>	a <sub>11</sub>	a <sub>8</sub>	a <sub>5</sub>	a <sub>2</sub>
a <sub>8</sub>	a <sub>2</sub>	a <sub>11</sub>	a <sub>8</sub>	a <sub>5</sub>
a <sub>11</sub>	a <sub>5</sub>	a <sub>2</sub>	a <sub>11</sub>	a <sub>8</sub>

be the non commutative and non associative subset subsemiring of the subgroupoid ring ZH<sub>2</sub>.

Clearly ZH<sub>1</sub> ∩ ZH<sub>2</sub> = φ but both of them are of infinite order. Also S<sub>1</sub> ∩ S<sub>2</sub> = φ and S<sub>1</sub> and S<sub>2</sub> are infinite non commutative and non associative subset subsemirings of S.

Consider S<sub>3</sub> = {collection of all subsets of the subgroupoid ring ZH<sub>3</sub> where H<sub>3</sub> = {a<sub>1</sub>, a<sub>4</sub>, a<sub>7</sub>, a<sub>10</sub>} ⊆ G is given by the following table;

*	a <sub>1</sub>	a <sub>4</sub>	a <sub>7</sub>	a <sub>10</sub>
a <sub>1</sub>	a <sub>4</sub>	a <sub>1</sub>	a <sub>10</sub>	a <sub>7</sub>
a <sub>4</sub>	a <sub>7</sub>	a <sub>4</sub>	a <sub>1</sub>	a <sub>10</sub>
a <sub>7</sub>	a <sub>10</sub>	a <sub>7</sub>	a <sub>4</sub>	a <sub>1</sub>
a <sub>10</sub>	a <sub>1</sub>	a <sub>10</sub>	a <sub>7</sub>	a <sub>4</sub>

be the non associative non commutative subset subsemiring of the subgroupoid ring ZH<sub>3</sub>.

We see S<sub>3</sub> ∩ S<sub>1</sub> = {φ}. All the three subset subsemirings are non commutative and non associative and are disjoint. We see this subset semiring is not strictly non commutative;

for take A = {a<sub>6</sub>} and B = {a<sub>0</sub>} in S.

$$\begin{aligned}
 A * B &= \{a_6\} * \{a_0\} \\
 &= \{a_6 * a_0\} \\
 &= \{a_6\} \qquad \dots \qquad \text{I}
 \end{aligned}$$

$$\begin{aligned}
 \text{Consider } B^*A &= \{a_0\} * \{a_6\} \\
 &= \{a_0 * a_6\} \\
 &= \{a_6\} \qquad \dots \qquad \text{II}
 \end{aligned}$$

I and II are identical this S has elements A, B such that  $A*B = B*A$  so S is not a strictly non commutative subset semiring of ZG.

Hence  $S_1$  is also not a strictly non commutative subset subsemiring of S of the subgroupoid ring  $ZH_1$ .

Consider  $S_2$  we take  $A = \{a_2\}$  and  $B = \{a_8\} \in S_2$ .

$$\begin{aligned}
 \text{We see } A * B &= \{a_2\} * \{a_8\} \\
 &= \{a_2 * a_8\} \\
 &= \{a_2\} \qquad \dots \qquad \text{I}
 \end{aligned}$$

$$\begin{aligned}
 \text{But } B^*A &= \{a_8\} * \{a_2\} \\
 &= \{a_8 * a_2\} \\
 &= \{a_2\} \qquad \dots \qquad \text{II}
 \end{aligned}$$

We see I and II are identical so  $A*B = B*A$  in  $S_2$  so  $S_2$  is not a strictly non commutative subsemiring of the subgroupoid ring  $ZH_2$ .

Finally we study whether  $S_3$  is strictly non commutative.

Consider  $A = \{a_1\}$  and  $B = \{a_7\}$  in  $S_3$ .

Consider

$$\begin{aligned}
 A*B &= \{a_1\} * \{a_7\} \\
 &= \{a_1 * a_7\} \\
 &= \{a_{10}\} \qquad \dots \qquad \text{I}
 \end{aligned}$$

$$\begin{aligned}
 \text{Now } B^*A &= \{a_7\} * \{a_1\} \\
 &= \{a_7 * a_1\} \\
 &= \{a_{10}\} \qquad \dots \qquad \text{II}
 \end{aligned}$$

We see I and II are identical thus  $S_3$  is also not a strictly non commutative subset subsemiring of the subgroupoid ring  $ZH_3$ .

**Example 2.28:** Let  $S = \{\text{Collection of all subsets of the groupoid ring } Z_2G \text{ where } G \text{ is the groupoid given by the following table;}$

*	1	$a_0$	$a_1$	$a_2$
1	1	$a_0$	$a_1$	$a_2$
$a_0$	$a_0$	1	$a_2$	$a_1$
$a_1$	$a_1$	$a_2$	1	$a_0$
$a_2$	$a_2$	$a_1$	$a_0$	1

be the subset non associative semiring of finite order. Clearly  $S$  is a commutative semiring.

Let  $A = \{1 + a_0\} \in S$ .

We see

$$A * A = \{(1 + a_0) * (1 + a_0)\} = \{0\}$$

so  $S$  has subset nilpotent elements of order two.

In fact  $B = \{1 + a_1\}$  in  $S$  is such that

$$\begin{aligned} B * B &= \{1 + a_1\} * \{1 + a_1\} \\ &= \{(1 + a_1) * (1 + a_1)\} = \{0\}. \end{aligned}$$

$B$  is also a subset nilpotent element of  $S$ .

Consider  $D = \{1 + a_0 + a_1 + a_2\} \in S$

$D * D = \{0\}$  is a subset nilpotent element of  $S$ .

We see  $S$  has also subset units take  $P = \{1 + a_0 + a_1\} \in S$

$$\begin{aligned} P * P &= \{(1 + a_0 + a_1) * (1 + a_0 + a_1)\} \\ &= \{1 * 1 + 1 * a_0 + 1 * a_1 + a_0 * 1 + a_0 * a_0 + \\ &\quad a_0 * a_1 + a_1 * 1 + a_1 * a_0 + a_1 * a_1\} \\ &= \{1 + a_0 + a_1 + a_0 + a_1 + 1 + a_2 + a_2 + 1\} \\ &= \{1\}. \end{aligned}$$

Thus P is subset unit in S.

It is easily verified  $M = \{1 + a_1 + a_2\}$  in S is also a subset unit in S.

**Example 2.29:** Let  $S = \{\text{Collection of all subsets of the groupoid ring } Z_2G \text{ where } G \text{ is the groupoid given by the following table;}$

*	e	$a_0$	$a_1$	$a_2$	$a_3$	$a_4$
e	e	$a_0$	$a_1$	$a_2$	$a_3$	$a_4$
$a_0$	$a_0$	e	$a_2$	$a_4$	$a_1$	$a_3$
$a_1$	$a_1$	$a_2$	e	$a_1$	$a_3$	$a_0$
$a_2$	$a_2$	$a_4$	$a_1$	e	$a_0$	$a_2$
$a_3$	$a_3$	$a_1$	$a_3$	$a_0$	e	$a_4$
$a_4$	$a_4$	$a_3$	$a_0$	$a_2$	$a_4$	e

be the subset non associative semiring of the groupoid ring  $Z_2G$ .

We see  $A = \{\{e + a_0 + a_1 + a_2 + a_3 + a_4, 0\}\} \subseteq S$  is a subset semiring ideal of S.

We define for subset non associative semirings the notion of left semiring semiideal subset non associative semiring. A non empty subset  $B \subseteq S$  is a left semisubset semiring ideal of S if

- (i) B is a subset subsemiring.
- (ii)  $x^2b \in B$  for all  $x \in S$  and  $b \in B$ .

Similarly one can define the notion of subset right semiideal of a subset semiring S. We call B to be a subset semiideal if it is both a subset right semiideal as well as subset left semiideal.

Interested readers are requested to supply examples.

Now on similar lines we can define strong subset left semiideal and strong subset right semiideal of a subset semiring.

We say if in a subset non associative semiring  $S$  we have a closed subset  $A$  ( $A$  a subset of  $S$  which is closed under the operation  $*$  such that  $A$  is a subset subsemiring of  $S$ ).

We call  $A$  the strong subset semiring semiideal of  $S$  if  $(xy)s \in A$  ( $s(xy) \in A$ ) for every pair of subsets  $x$  and  $y$  in  $S$  and  $s$  in  $A$ .

We also expect the interested reader to provide examples of this notion [79].

Now we finally define the notion of Smarandache left semiideal of a subset non associative semiring (Smarandache right semiideal of the subset non associative semiring  $S$ ). Let  $S$  be a non associative subset semiring. A non empty subset  $A$  of  $S$  is said to be a Smarandache subset left semiideal of  $S$  if

(i)  $A$  is a  $S$ -subset subsemiring of  $S$  (That is  $A$  is a Smarandache subset subsemiring of  $S$ ).

(ii)  $x^2 s \in A$  for all  $x \in S$  and  $s \in A$ .

On similar lines we can define the notion of Smarandache subset right semiideal of the subset semiring. If  $A$  is both a subset left Smarandache semiideal as well as a subset right Smarandache semiideal we define  $A$  to be a Smarandache semiideal of the subset non associative semiring  $S$ .

**Example 2.30:** Let  $S = \{\text{collection of all subsets of the groupoid ring } LG \text{ where } L =$

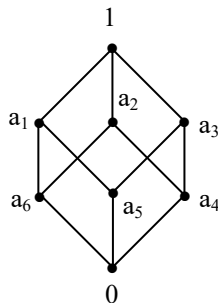



and  $G = \{Z_{12}, (3, 4), *\}$  be the non associative subset semiring. We can find substructures of S.

The reader is left with the task of finding subset units and subset zero divisors if any in S.

**Example 2.31:** Let  $S = \{\text{Collection of all subsets of the groupoid ring } Z_2G \text{ where } G \text{ is the groupoid given by the following table;}$

*	e	$a_0$	$a_1$	$a_2$
e	e	$a_0$	$a_1$	$a_2$
$a_0$	$a_0$	e	$a_2$	$a_1$
$a_1$	$a_1$	$a_2$	e	$a_0$
$a_2$	$a_2$	$a_1$	$a_0$	e

be the subset non associative semiring of the groupoid ring  $Z_2G$ .

Take  $A = \{1 + a_0 + a_1 + a_2\}$  and  $B = \{1 + a_0\} \in S$  we see  $A * B = \{0\}$ . Choose  $X = \{a_2 + a_0\}$  and  $Y = \{a_2 + a_1\} \in S$ . Further  $A * X = \{0\}$  and  $B * Y = \{0\}$ , but  $X * Y \neq \{0\}$ .

Thus we see S has subset S-zero divisors we just give the definition of the notion of Smarandache subset commutative pseudo pair S of a subset non commutative semiring of a groupoid ring (groupoid semiring).

Let  $A \subseteq S$  be a S-subset non associative subsemiring of S.

A pair of subsets  $X, Y \in A$  which are such that  $X * Y = Y * X$  is said to be a Smarandache subset pseudo commutative pair (S-pseudo commutative pair) of S if

$$X * (A_1 * Y) = Y * (A_1 * X) \text{ or } (Y * A_1) * X \text{ or } Y = Y * (Y * A_1) * X \text{ or } Y * (A_1 * X) \text{ for all } A_1 \in A.$$

If in the S-subset subsemiring A, every subset commutative pair happens to be a Smarandache pseudo subset commutative pair of A then A is said to be a Smarandache pseudo commutative subset semiring. We say a non empty subset of a subset non associative semiring P of the subset semiring S to be a closed net in S; if P is a closed set and P is generated by a single element.

**Example 2.32:** Let  $S = \{ \text{Collection of all subsets from the groupoid ring } Z_7G \text{ where } G \text{ is given by the following table;}$

*	a <sub>0</sub>	a <sub>1</sub>	a <sub>2</sub>	a <sub>3</sub>	a <sub>4</sub>
a <sub>0</sub>	a <sub>0</sub>	a <sub>4</sub>	a <sub>3</sub>	a <sub>2</sub>	a <sub>1</sub>
a <sub>1</sub>	a <sub>2</sub>	a <sub>1</sub>	a <sub>0</sub>	a <sub>4</sub>	a <sub>3</sub>
a <sub>2</sub>	a <sub>4</sub>	a <sub>3</sub>	a <sub>2</sub>	a <sub>1</sub>	a <sub>6</sub>
a <sub>3</sub>	a <sub>1</sub>	a <sub>0</sub>	a <sub>4</sub>	a <sub>3</sub>	a <sub>2</sub>
a <sub>4</sub>	a <sub>3</sub>	a <sub>2</sub>	a <sub>1</sub>	a <sub>0</sub>	a <sub>4</sub>

be the subset non associative semiring of the groupoid ring  $Z_7G$ .

Consider  $P = \{a_0 + a_1\} \in S$ ,

$$\begin{aligned}
 P^2 &= \{a_0 + a_1\} * \{a_0 + a_1\} \\
 &= \{(a_0 + a_1) * (a_0 + a_1)\} \\
 &= \{a_0 + a_1 + a_4 + a_2\} \in S.
 \end{aligned}$$

$$\begin{aligned}
 P^3 &= \{(a_0 + a_1) * (a_0 + a_1 + a_2 + a_4)\} \\
 &= \{a_0 + a_4 + a_3 + a_1 + a_2 + a_1 + a_0 + a_3\} \\
 &= \{2a_0 + 2a_3 + 2a_1 + a_2 + a_4\} \in S.
 \end{aligned}$$

$$\begin{aligned}
 P^4 &= \{\{2a_0 + 2a_3 + 2a_1 + a_2 + a_4\} * \{a_0 + a_4\}\} \\
 &= \{2a_0 + 2a_1 + 2a_2 + a_4 + a_3 + 2a_4 + 2a_0 \\
 &\quad + 2a_1 + a_4 + a_3\} \\
 &= \{4a_0 + 4a_4 + 4a_1 + 2a_3 + 2a_2\}.
 \end{aligned}$$

We see  $P \in S$  generates a subset non associative subsemiring and  $A = \{P, P^2, \dots, P^t\} \{t < \infty\}$  is a closed subset net of S.

Take  $M = \{a_0\}$ , then  $M$  itself is a closed subset net of  $S$ .  
 Each  $N_i = \{a_i\} \in S, 0 \leq i \leq 4$  are closed subset nets of  $S$ .

We say if for every  $A, B \in S$  ( $S$  a subset non associative semiring of a groupoid ring  $RG$ ) satisfies  $(A*B)^n = A*B$  for  $n = n(A, B) > 1$ , then we define  $S$  to be a strongly regular ring. Let  $S$  be a subset non associative semiring and  $P \subseteq S$  be a  $S$ -additive subset semigroup of  $S$ .  $P$  is called the Smarandache  $n$ -capacitor group of  $S$  if  $x^n P \subseteq P$  for every  $x \in S, n \geq 1$ .

**Example 2.33:** Let  $S = \{\text{Collection of all subsets of the groupoid ring } Z_2G \text{ where } G \text{ is given by the following table;}$

*	$a_0$	$a_1$	$a_2$	$a_3$	$a_4$	$a_5$
$a_0$	$a_0$	$a_2$	$a_4$	$a_0$	$a_2$	$a_4$
$a_1$	$a_2$	$a_4$	$a_0$	$a_2$	$a_4$	$a_0$
$a_2$	$a_4$	$a_0$	$a_2$	$a_4$	$a_0$	$a_2$
$a_3$	$a_0$	$a_2$	$a_4$	$a_0$	$a_2$	$a_4$
$a_4$	$a_2$	$a_4$	$a_0$	$a_2$	$a_4$	$a_0$
$a_5$	$a_4$	$a_0$	$a_2$	$a_4$	$a_0$	$a_2$

be the subset non associative semiring of the groupoid ring  $Z_2G$ .

Take  $P = \{\text{Collection of all subsets of the subgroupoid ring } Z_2H \text{ where } H = \{a_0, a_2, a_4\} \text{ is a subgroupoid of } G \text{ given by the following table;}$

*	$a_0$	$a_2$	$a_4$
$a_0$	$a_0$	$a_4$	$a_2$
$a_2$	$a_4$	$a_2$	$a_0$
$a_4$	$a_2$	$a_0$	$a_4$

be the subset non associative subsemiring of  $S$ .

Clearly  $P$  is a Smarandache subset semigroup and  $x^n P \subseteq P$  for every  $x \in S$ . Hence  $P$  is the Smarandache subset  $n$ -capacitor group of  $S$ .

Let  $S$  be a subset non associative semiring of a groupoid ring  $RG$ . A subset  $P$  of  $S$  is a radical if

- (i)  $P$  is a subset ideal of  $S$ .
- (ii)  $P$  is a nil subset ideal.
- (iii)  $T/P$  where ( $T = \{\text{Collection of all subsets of } R\}$ ) has no subset non zero nilpotent subset right ideals.

We can define similarly the notion of Smarandache radical subset semiring ideal of  $S$ .

We now proceed onto describe subset subring left link and subset subring right link of a subset non associative semiring of a groupoid ring.

Let  $S$  be a subset non associative semiring of a groupoid ring  $RG$ . We say a pair  $A, B \in S$  has a weakly subset subsemiring link with a subset subsemiring  $P$  in  $S \setminus \{A, B\}$  if either  $A \in P*B$  or  $B \in P*A$  or used in the strict sense and we have a subset subsemiring;

$$Q \subseteq S \quad Q \neq P \text{ such that} \\ B = Q*A \text{ (or } A = Q*B).$$

We say pair  $A, B \in S$  is one way weakly subset subsemiring link related, if we have a subset subsemiring  $P \subseteq S \setminus \{A, B\}$  such that for no subset subsemiring;

$$W \subseteq S \setminus \{A, B\} \text{ we have } B = S * A.$$

We define for a pair  $A, B \in S$  to have a Smarandache subset subsemiring link relation ( $S$ -subset subsemiring left link relation) if there exists a  $S$ -subset subsemiring  $P$  in  $S \setminus \{A, B\}$  such that  $A \in P*B$  and  $Y \in P*A$ .

If it has both a Smarandache subset left and subset right link relation for the same S-subset subsemiring P then we say A and B have a Smarandache subset subsemiring link (S-subset subsemiring link).

We say  $A, B \in S$  is a Smarandache weak subset subsemiring link (S-weak subset subsemiring link) with a S-subset subsemiring P in  $S \setminus \{A, B\}$  if either  $A \in P*B$  or  $B \in P*A$  (or used in strictly mutually exclusive sense) we have a S-subset subsemiring  $Q \neq P$  such that  $B = Q*A$  (or  $A = Q*B$ ).

We say a pair  $A, B \in S$  is said to be Smarandache oneway weakly subset subsemiring link related (S-oneway subset weakly link related) if we have a S-subset subsemiring  $P \subseteq S \setminus \{A, B\}$  such that  $A = P*B$  and for no subset subsemiring  $Q \subseteq S \setminus \{A, B\}$  we have  $B = Q*A$ .

Let S be a subset non associative semiring of a groupoid ring. A Smarandache subset subsemiring X of S is said to be Smarandache essential subset subsemiring (S-essential subset subsemiring) of S if the intersection of X with any other S-subset subsemiring is zero. If every S-subset subsemiring of S is a Smarandache essential subset subsemiring of S then we call S to be a Smarandache essential subset subsemiring.

**Example 2.34:** Let  $S = \{\text{Collection of all subsets of the groupoid ring } Z_2G \text{ where } G \text{ is given by the following table};$

*	$a_0$	$a_1$	$a_2$	$a_3$
$a_0$	$a_0$	$a_2$	$a_0$	$a_2$
$a_1$	$a_2$	$a_0$	$a_2$	$a_0$
$a_2$	$a_0$	$a_2$	$a_0$	$a_2$
$a_3$	$a_2$	$a_0$	$a_2$	$a_0$

be the non associative semiring of the groupoid ring  $Z_2G$ .

We see

$P_1 = \{\text{Collection of all subsets of the groupoid ring } Z_2[a_0]\}$   
 be the subset subsemiring of S.  $P_2 = \{\text{Collection of all subsets of the subgroupoid ring } Z_2[a_0, a_1] \subseteq Z_2[a_0, a_1, a_2, a_3]\}$  be the subset subsemiring of S.  $P_3 = \{\text{Collection of all subsets of the subgroupoid ring } Z_2[a_2, a_3, a_0] \subseteq Z_2[a_0, a_1, a_2, a_3]\}$  be the subset subsemiring of S.  $P_4 = \{\text{Collection of all subsets of the subgroupoid ring } Z_2[a_0, a_1, a_2] \subseteq Z_2[a_0, a_1, a_2, a_3]\}$  be the subset subsemiring of S.

We see S is not a essential subset semiring or S does not contain even a single essential subset subsemiring.

Several of the results when we study for subset non associative semirings S may not be true for every element in S how ever if we have subset subsemiring in which the results hold good we accept it to be Smarandache special subset semiring for that result.

In most cases we see the subsets of S behave in an hap hazard way. Finally we are interested in defining topologies of these subset non associative semiring of a groupoid ring.

In first case if we define on  $S = \{\text{Collection of all subsets of a groupoid ring } RG\}$  the subset non associative semiring then  $T = \{S', \cup, \cap\}$ , usual union ‘ $\cup$ ’ of sets and intersection ‘ $\cap$ ’ of sets; T is the usual topological space of subset semirings.

However we can define new special topology on S with  $\cup_n$  and  $\cap_n$ .

For  $A, B \in S$ ,  $A \cup_n B = \{a + b \mid a \in A \text{ and } b \in B\}$  and  $A \cap_n B = \{a * b \mid a \in A \text{ and } b \in B\}$  then  $T_n = \{S, \cup_n, \cap_n\}$  is a special subset semiring topological space where  $A \cap_n B \neq B \cap_n A$  and  $(A \cap_n B) \cap_n C \neq A \cap_n (B \cap_n C)$  for  $A, B, C \in T_n$ .

Further  $A \cup A = A$  and  $A \cap A = A$  in T.

But in  $T_n$ ;  $A \cup_n A \neq A$  and  $A \cap_n A \neq A$  in general. Thus we get two topologies on  $S$ .

We will first illustrate this situation by some examples.

**Example 2.35:** Let  $S = \{\text{Collection of all subsets of the groupoid ring } Z_2G \text{ where } G \text{ is given by the following table;}$

*	a	b	c	d
a	a	c	a	c
b	a	c	a	c
c	a	c	a	c
d	a	c	a	c

be the subset non associative semiring.

Let  $A = \{b + a + c, a + c + da, a + d\}$   
 and  $B = \{a + c, a + d, c + b\} \in S$ .

$A \cup B = \{a + b + c, a + c + d, a, a + d, a + c, c + b\}$  and  
 $A \cup_n B = \{b, d, c, c + d, b + c + d, 0, a, a + b + c, b + d\}$ .

We see  $A \cup B \neq A \cup_n B$  for  $A, B \in S$  in general.

Now consider  $A \cap B = \{a + d\}$  but

$A \cap_n B = \{(b + a + c) * a + c, (a + c + d) * (a + c) a^*(a + 1),$   
 $(a+d) * (a+c), (b+a+c) * a+d,$   
 $(a+c+d) * (a+d), a * (a+d) (a+d) * (a+d),$   
 $(b+a+c) * (c+b) (a+c+d) * (c+b),$   
 $a * (c+b) (a+d) * (c+b)\}$

$= \{c + a + a + a + a + a, a + a + a + a + a + a, a + a,$   
 $a + a + a + a, a + a + a + c + c + c, a + a + a + c +$   
 $c + c, a + c, a + c + c + a, a + c + a + c + a + c,$   
 $a + c + a + c + a + c, a + c, a + c + c + a\}$

$= \{c + a, 0\}$ .

We see  $A \cap B \neq A \cap_n B$ .

Thus  $(T, \cup, \cap)$  is the usual topology of subset non associative semirings and  $\{T_n, \cup_n, \cap_n\}$  is the new non associative special topology on subset non associative semiring S. We see both have same basic set S except in T we take  $S' = S \cup \{\phi\}$  but are different topologies on S.

**Example 2.36:** Let  $S = \{\text{Collection of all subsets of the groupoid lattice LG where L is the lattice}$

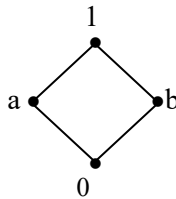

and G is the groupoid given by the following table;

*	0	1	2	3
0	0	3	2	1
1	2	1	0	3
2	0	3	2	1
3	2	1	0	3

be the subset non associative semiring of the groupoid lattice LG.

**Example 2.37:** Let  $S = \{\text{Collection of all subsets of the groupoid lattice LG where L is a chain lattice given below;}$





and the groupoid  $G$  is given by the following table;

*	$g_0$	$g_1$	$g_2$	$g_3$
$g_0$	$g_0$	$g_3$	$g_2$	$g_1$
$g_1$	$g_2$	$g_1$	$g_0$	$g_3$
$g_2$	$0$	$g_3$	$g_2$	$g_1$
$g_3$	$g_2$	$g_1$	$g_0$	$g_3$

be the subset non associative semiring.

$$\text{Let } A = \{a_1g_2 + a_3g_1 + g_0 + a_3g_3, g_2\} \text{ and}$$

$$B = \{a_1g_1 + a_2g_2 + a_3g_3 + a_0\} \in S.$$

$$\text{We find } A \cup A = A$$

$$= \{a_1g_2 + a_3g_1 + g_0 + a_3g_3, g_2\}.$$

and

$$A \cap A = \{a_1g_2 + a_3g_1 + g_0 + a_3g_3, g_2\} = A.$$

Consider

$$A \cup_n A = \{g_2 + a_3g_1 + g_0 + a_3g_3, a_1g_2 + a_3g_1 + a_3g_3 + g_0, g_2\}$$

$$\neq A.$$

$$A \cap_n A = \{g_2, a_1g_2 + a_3g_0 + g_2, (a_1g_2 + a_3g_1 + g_0 + a_3g_3)^*$$

$$(a_1g_2 + a_3g_1 + g_0 + a_3g_3)\}$$

$$= \{g_2, g_2 + g_3g_0, a_1g_2^* g_2 + a_3.a_1, g_1^* g_2, 1.a_1,$$

$$g_0^* g_2 + a_3. a_1 g_3^* a_2 + a_1.a_3 g_2^* g_1 + a_3.a_3$$

$$g_1^*g_1 + a_3. 1 g_0^* g_1 + a_3. a_3 g_3^* g_1 + a_1 g_2^* g_0 +$$

$$a_3.1 g_1^* g_0 + g_0^* g_0 + a_3. 1 g_3^* g_0 + a_1.a_3$$

$$g_2^*g_3 a_3.a_3 g_1^* g_3 + 1. a_3 g_0^* g_3 + a_3 . a_3 g_3^* g_3\}$$

$$= \{g_2, g_2 + a_3g_0, a_1g_2 + a_3g_0 + a_1g_2 + a_3g_0 + a_3g_3 +$$

$$a_3g_1 + a_3g_3 + a_1g_0 + a_3g_2 + a_3g_1 + g_0 + a_3g_2 +$$

$$a_3g_1 + a_3g_3 + a_3g_1 + a_3g_3\}$$

$$= \{g_2, g_2 + a_3g_0, a_1g_2 + a_3g_0 + a_3g_3 + a_3g_1 + g_0 + a_3g_2 + a_1g_0\} \neq A.$$

Thus we see  $\{T, \cup, \cap\}$  and  $\{T_n, \cup_n, \cap_n\}$  are distinct subset non associative semiring topologies of finite order.

**Example 2.38:** Let  $S = \{\text{Collection of all subsets of the groupoid ring } ZG \text{ where } G \text{ is the groupoid given by the following table;}$

*	$g_0$	$g_1$	$g_2$	$g_3$	$g_4$	$g_5$	$g_6$	$g_7$
$g_0$	$g_0$	$g_6$	$g_4$	$g_2$	$g_0$	$g_6$	$g_4$	$g_2$
$g_1$	$g_2$	$g_0$	$g_6$	$g_4$	$g_2$	$g_0$	$g_6$	$g_4$
$g_2$	$g_4$	$g_2$	$g_0$	$g_6$	$g_4$	$g_2$	$g_0$	$g_6$
$g_3$	$g_6$	$g_4$	$g_2$	$g_0$	$g_6$	$g_4$	$g_2$	$g_0$
$g_4$	$g_0$	$g_6$	$g_4$	$g_2$	$g_0$	$g_6$	$g_4$	$g_2$
$g_5$	$g_2$	$g_0$	$g_6$	$g_4$	$g_2$	$g_0$	$g_6$	$g_4$
$g_6$	$g_4$	$g_2$	$g_0$	$g_6$	$g_4$	$g_2$	$g_0$	$g_6$
$g_7$	$g_6$	$g_4$	$g_2$	$g_0$	$g_6$	$g_4$	$g_2$	$g_0$

be the subset non associative semiring of  $ZG$  of infinite order.  $\{T, \cup, \cap\}$  and  $\{T_n, \cup_n, \cap_n\}$  ( $T = T_n$ ) are two subset non associative semiring topologies of infinite order.

We see if  $A = \{g_0 + g_3 + 5g_2, 4g_1 + 7g_3 + 2g_4 + 3g_7\} \in S$

then  $A \cup A = A$  and  $A \cap A = A$  but

$$A \cup_n A = \{g_0 + 8g_3 + 5g_1 + 4g_1 + 2g_4 + 3g_7\} \neq A.$$

$$A \cap_n A = \{(g_0 + g_3 + 5g_2) * (g_0 + g_3 + 5g_2), (g_0 + g_3 + 5g_2) * (4g_1 + 7g_3 + 2g_4 + 3g_7), (4g_1 + 7g_3 + 2g_4 + 3g_7) * (g_0 + g_3 + 5g_2), (4g_1 + 7g_3 + 2g_4 + 3g_7) * (4g_1 + 7g_3 + 2g_4 + 3g_7)\} \neq A.$$

Thus we see the two topological spaces are different.

Infact  $A \cap_n A \neq A$  and  $(A \cap_n B) \cap_n C \neq A \cap_n (B \cap_n C)$  for  $A, B, C \in S$  in  $(T_n, \cup_n, \cap_n)$ .

**Example 2.39:** Let  $S = \{\text{Collection of all subsets of the groupoid semiring } (Z^+ \cup \{0\}) G \text{ where } G \text{ is a groupoid given by the following table;}$

*	$g_0$	$g_1$	$g_2$	$g_3$	$g_4$	$g_5$	$g_6$	$g_7$	$g_8$	$g_9$
$g_0$	$g_0$	$g_6$	$g_2$	$g_8$	$g_4$	$g_0$	$g_6$	$g_2$	$g_8$	$g_4$
$g_1$	$g_5$	$g_1$	$g_7$	$g_3$	$g_9$	$g_5$	$g_1$	$g_7$	$g_3$	$g_9$
$g_2$	$g_0$	$g_6$	$g_2$	$g_8$	$g_4$	$g_0$	$g_6$	$g_2$	$g_8$	$g_4$
$g_3$	$g_5$	$g_1$	$g_7$	$g_3$	$g_9$	$g_5$	$g_1$	$g_7$	$g_3$	$g_9$
$g_4$	$g_0$	$g_6$	$g_2$	$g_8$	$g_4$	$g_0$	$g_6$	$g_2$	$g_8$	$g_4$
$g_5$	$g_5$	$g_1$	$g_7$	$g_3$	$g_9$	$g_5$	$g_1$	$g_7$	$g_3$	$g_9$
$g_6$	$g_0$	$g_6$	$g_2$	$g_8$	$g_4$	$g_0$	$g_6$	$g_2$	$g_8$	$g_4$
$g_7$	$g_5$	$g_1$	$g_7$	$g_3$	$g_9$	$g_5$	$g_1$	$g_7$	$g_3$	$g_9$
$g_8$	$g_0$	$g_6$	$g_2$	$g_8$	$g_4$	$g_0$	$g_6$	$g_2$	$g_8$	$g_4$
$g_9$	$g_5$	$g_1$	$g_7$	$g_3$	$g_9$	$g_5$	$g_1$	$g_7$	$g_3$	$g_9$

be the subset non associative semiring of the groupoid semiring  $(Z^+ \cup \{0\}) G$ . We see both the topological spaces associated with  $\{T, \cup, \cap\}$  and  $\{T_n, \cup_n, \cap_n\}$  are unique and distinct.

Further we see if  $A = \{5g_0 + 6g_3 + 8g_4, 2g_9 + g_3 + g_7\}$  and  $B = \{2g_1 + g_8\} \in S$  then  $A \cup A = A$  and

$$A \cap A = A.$$

$$A \cup B = \{2g_1 + g_8, 5g_0 + 6g_3 + 8g_4, 2g_9 + g_3 + g_7\}.$$

Now

$$A \cap_n B = \{(5g_0 + 6g_3 + 8g_4) * (2g_1 + g_8), (2g_9 + g_3 + g_7) * (2g_1 + g_8)\}$$

$$\begin{aligned}
 &= \{10g_0 * g_1 + 12g_3 * g_1 + 16g_4 * g_1 + 5g_0 * g_8 + \\
 &\quad 6g_3 * g_8 + 8g_4 * g_8, 4g_9 * g_1 + 2g_3 * g_1 + 2g_7 * g_1 \\
 &\quad + 2g_9 * g_8 + g_3 * g_8 + g_7 * g_8\} \\
 &= \{10g_6 + 12g_1 + 16g_6 + 5g_8 + 6g_3 + 8g_8, 4g_1 + \\
 &\quad 2g_1 + 2g_3 + g_3 + g_3\} \\
 &= \{26g_6 + 12g_1 + 13g_8 + 6g_3, 8g_1 + 4g_3\}.
 \end{aligned}$$

$$A \cup_n B = \{5g_0 + 6g_3 + 8g_4 + 2g_1 + g_8, 2g_9 + g_3 + g_7 + \\
 g_8 + 2g_1\}.$$

Thus we get two distinct subset non associative semiring topological spaces of infinite order.

Now we can for any subset non associative semiring  $S$  take the collection of all subset semiring ideals. On the subset ideals we can define a topology with usual ' $\cup$ ' and ' $\cap$ '. Of course  $A \cup B$  for any two subset semiring ideals results in a ideal generated by  $A$  and  $B$ .

We know  $A \cap B$  is an subset semiring ideal. Thus if  $P$  denotes the collection of all subset ideals of  $S$ .  $\{P', \cup, \cap\}$  is a subset semiring ideal topological subset semiring space.

Nothing prevents us from building another new subset ideal topological space  $\{P, \cup_n, \cap_n\}$  where  $A \cup_n B$  generates a subset ideal of  $S$ . We see  $\{P, \cup_n, \cap_n\}$  is also a new subset ideal nonassociative topological space of the subset semiring.

Interested reader is expected to construct examples of these. Thus so far with a given subset semiring we are in a position to associate four distinct topological spaces.

We can also for a subset non associative semiring  $S$ , consider the collection of all subset subsemiring of  $S$  and if  $M = \{\text{Collection of all subset subsemirings of } S\}$  then we can give two different topologies on  $M$ .

$\{M', \cup, \cap\}$  where  $A \cup B$  for  $A, B \in M$  is defined as the subset subsemiring generated by  $A$  and  $B$ . Thus  $\{M, \cup, \cap\}$  is defined as the subset subsemiring topological space of the subset non associative semiring  $S$ .

Now if we define on  $M$ ;  $\cup_n$  and  $\cap_n$  then we assume  $A \cup_n B$  generates a subset subsemiring and  $A \cap_n B$  also generates a subset subsemiring and  $\{M, \cup_n, \cap_n\}$  gives a new subset subsemiring topological space of the subset semiring  $S$  of a groupoid ring.

Hence we have defined 6 distinct topologies on  $S$ .

Now we can have several topologies on  $S$  by defining the concept of set subset semiring ideals of a subset semiring of a groupoid ring.

To this end we just define the notion of set subset semiring ideals of a subset semiring of a groupoid ring.

**DEFINITION 2.2:** *Let  $S$  be the subset non associative semiring of a groupoid ring (groupoid semiring). Let  $P \subseteq S$  be a proper subset of  $S$ . Let  $M \subseteq S$  be a subset subsemiring of  $S$ .*

*We say  $P$  is a set subset semiring left ideal of  $S$  over the subset subsemiring  $M$  of  $S$  if for all  $p \in P$  and  $m \in M$ ,  $mp \in P$ .*

*On similar lines we can define set subset semiring right ideal of  $S$  over the subset subsemiring. If  $P$  is both a set subset semiring right ideal of  $S$  over  $M$  as well as set subset semiring left ideal of  $S$  over  $M$  then we define  $P$  to be a set subset semiring ideal of  $S$  over the subset subsemiring  $M$  of  $S$ .*

We first give some examples of them.

**Example 2.40:** Let  $S = \{\text{Collection of all subsets of a groupoid ring } Z_6G \text{ where } G \text{ is a groupoid given by the following table};$

*	$g_0$	$g_1$	$g_2$	$g_3$
$g_0$	$g_0$	$g_3$	$g_2$	$g_1$
$g_1$	$g_2$	$g_1$	$g_0$	$g_3$
$g_2$	$g_0$	$g_3$	$g_2$	$g_1$
$g_3$	$g_2$	$g_1$	$g_0$	$g_3$

be the subset non associative subset semiring of the groupoid ring  $Z_6G$ .

Let  $M = \{\{3g_0\}, \{3g_1\}, \{3g_2\}, \{3g_3\}, \{3g_4\}, \{0\}\} \cup \{3g_0 + 3g_1\}, \{3g_0 + 3g_2\}, \dots, \{3g_3 + 3g_4\}, \dots, \{3g_0 + 3g_1 + 3g_2 + 3g_3 + 3g_4\} \subseteq S$ .

Take the set

$P = \{\{2g_0\}, 0, \{2g_4\}, \{2g_1 + 2g_3\}, \{2g_0 + 2g_1 + 2g_2 + 2g_3\}\} \subseteq S$ .

$P$  is a set subset semiring ideal of the subset semiring  $S$  over the subset subsemiring  $M$  of  $S$ .

**Example 2.41:** Let

$S = \{\text{Collection of all subsets of the groupoid ring } ZG\}$  be the subset non associative semiring of the groupoid ring  $ZG$  where the table for the groupoid  $G$  is as follows:

*	$g_0$	$g_1$	$g_2$	$g_3$	$g_4$	$g_5$
$g_0$	$g_0$	$g_3$	$g_0$	$g_3$	$g_0$	$g_3$
$g_1$	$g_4$	$g_1$	$g_4$	$g_1$	$g_4$	$g_1$
$g_2$	$g_2$	$g_5$	$g_2$	$g_5$	$g_2$	$g_5$
$g_3$	$g_0$	$g_3$	$g_0$	$g_3$	$g_0$	$g_3$
$g_4$	$g_4$	$g_1$	$g_4$	$g_1$	$g_4$	$g_1$
$g_5$	$g_2$	$g_5$	$g_2$	$g_5$	$g_2$	$g_5$

Take  $M = \{\text{Collection of all subsets of the groupoid ring } Z(g_0, g_2, g_4)\} \subseteq ZG$  given by the table:

$$\left. \begin{array}{c|c|c|c} * & g_0 & g_2 & g_4 \\ \hline g_0 & g_0 & g_0 & g_0 \\ \hline g_2 & g_2 & g_2 & g_2 \\ \hline g_4 & g_4 & g_4 & g_4 \end{array} \right\}$$

be the subset subsemiring S.

$P = \{ \text{Collection of all subsets of } 2Z(g_0, g_2, g_4), 5Z(g_0, g_2, g_4), 7Z(g_0, g_2, g_4) \}$  be the set subset semiring ideal of the subset semiring S over the subset subsemigroup M.

$P_1 = \{ \text{Collection of all subsets of } 19Z(g_0, g_2, g_4), 23Z(g_0, g_2, g_4) \} \subseteq S$ ,  $P_1$  is again a set subset semiring ideal of the subset semiring S over the subset subsemigroup M of S.

Consider  $P_2 = \{ \text{Collection of all subsets of } 43Z(g_0, g_2, g_4), 53Z(g_0, g_2, g_4) \} \subseteq S$  is also a set subset semiring ideal of the subset semiring S over the subset subsemiring M of S.

Thus it is pertinent to keep on record that we can for a given subset subsemigroup M of S have several set semiring ideal subset semirings of S over that subset subsemigroup M of S. Infact there are infinite number of subset set semiring ideals of S over M.

In view of this example we define  $W = \{ \text{Collection of all set subset semiring ideals of S over a fixed subset subsemiring M of S} \}$ .

We can on W give two topologies one usual topology with  $\cup$  and  $\cap$  and another a new topology  $\cup_n$  and  $\cap_n$ .

Thus we have two distinct topologies on W.

**Example 2.42:** Let  $S = \{ \text{Collection of all subsets of the groupoid ring } Z_4G \text{ where } G \text{ is a groupoid given by the following table;} \}$

*	$g_0$	$g_1$	$g_2$	$g_3$	$g_4$	$g_5$
$g_0$	$g_0$	$g_0$	$g_0$	$g_0$	$g_0$	$g_0$
$g_1$	$g_3$	$g_3$	$g_3$	$g_3$	$g_3$	$g_3$
$g_2$	$g_0$	$g_0$	$g_0$	$g_0$	$g_0$	$g_0$
$g_3$	$g_3$	$g_3$	$g_3$	$g_3$	$g_3$	$g_3$
$g_4$	$g_0$	$g_0$	$g_0$	$g_0$	$g_0$	$g_0$
$g_5$	$g_3$	$g_3$	$g_3$	$g_3$	$g_3$	$g_3$

be the subset non associative semiring. Clearly S is of finite order.

Take  $M = \{ \text{Collection of all subsets of the groupoid ring } Z_4\{g_0, g_3\} \subseteq Z_4G \subseteq S; M \text{ is a subset subsemiring of } S.$

Now  $P = \{ \text{Collection of all subsets of } Z_4\{g_0, g_3\}, Z_4\{g_1, g_2\}, Z_4\{g_2, g_5\} \} \subseteq S; P \text{ is only a subset of the subset semiring } S.$

Clearly P is a set ideal subset semiring of the subset semiring S over the subset subsemiring M of S.

$W = \{ \text{Collection of all subset set semiring ideals of } S \text{ over the subset subsemiring } M \text{ of } S \}.$

On W we can give two distinct topologies viz  $\{W', \cup, \cap\}$  and  $\{W, \cup_n, \cap_n\}$  they are the usual set subset semiring ideal topological spaces of the subset semiring S over the subset subsemiring M of S and new subset semiring set ideal topological space of the subset subsemiring M of S respectively.

**Example 2.43:** Let  $S = \{ \text{Collection of all subsets of the groupoid ring } Z_6G \text{ where } G \text{ is given by the following table;} \}$



*	$g_0$	$g_1$	$g_2$	$g_3$	$g_4$	$g_5$	$g_6$	$g_7$
$g_0$	$g_0$	$g_0$	$g_0$	$g_0$	$g_0$	$g_0$	$g_0$	$g_0$
$g_1$	$g_2$	$g_2$	$g_2$	$g_2$	$g_2$	$g_2$	$g_2$	$g_2$
$g_2$	$g_4$	$g_4$	$g_4$	$g_4$	$g_4$	$g_4$	$g_4$	$g_4$
$g_3$	$g_6$	$g_6$	$g_6$	$g_6$	$g_6$	$g_6$	$g_6$	$g_6$
$g_4$	$g_0$	$g_0$	$g_0$	$g_0$	$g_0$	$g_0$	$g_0$	$g_0$
$g_5$	$g_2$	$g_2$	$g_2$	$g_2$	$g_2$	$g_2$	$g_2$	$g_2$
$g_6$	$g_4$	$g_4$	$g_4$	$g_4$	$g_4$	$g_4$	$g_4$	$g_4$
$g_7$	$g_6$	$g_6$	$g_6$	$g_6$	$g_6$	$g_6$	$g_6$	$g_6$

be the subset non associative semiring of the groupoid ring  $Z_6G$ .

Take  $M = \{ \text{Collection of all subsets of the groupoid subring } \{0, 3\}G \subseteq G; M \text{ is a subset subsemiring of the groupoid subring } \{0, 3\}G \text{ of the subset semiring } S.$

Take

$P_1 = \{ \text{Subsets of } \{0, 2, 4\} \{g_3, g_1\}, \{0, 2, 4\} \{g_5, g_7\} \} \subseteq S; P_1$  is a subset set ideal of  $S$  over the subset subsemiring  $M$  of  $S$ .

We have several such set ideals over  $M$  but they are only finite in number.

Consider  $W = \{ \text{Collection of all set subset ideal of the subset semiring } S \text{ over the subset subsemiring } M \text{ of } S \} \subseteq S;$  we can give two distinct topologies on  $W; (W, \cup, \cap)$  and  $\{W, \cup_n, \cap_n\}.$

Thus by varying the subset subsemiring  $M$  of  $S$  we can get several such topological spaces defined over  $M$ .

By this method we can get several distinct topological spaces.

Interested reader can study them.

**Example 2.44:** Let  $S = \{\text{Collection of all subsets of the groupoid lattice } LG \text{ where } L \text{ is a lattice given by}$

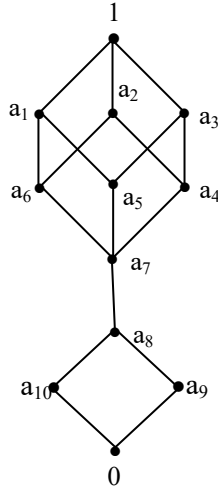

and the groupoid  $G$  is given by the following table;

*	0	1	2	3	4	5	6	7	8	9
0	0	4	8	2	6	0	4	8	2	6
1	2	6	0	4	8	2	6	0	4	8
2	4	8	2	6	0	4	8	2	6	0
3	6	0	4	8	2	6	0	4	8	2
4	8	2	6	0	4	8	2	6	0	4
5	0	4	8	2	6	0	4	8	2	6
6	2	6	0	4	8	2	6	0	4	8
7	4	8	2	6	0	4	8	2	6	0
8	6	0	4	8	2	6	0	4	8	2
9	8	2	6	0	4	8	2	6	0	4

be the subset non associative subsemiring of  $S$  over the groupoid lattice  $LG$ .

Take  $M = \{\text{Collection of all subsets of the subgroupoid lattice LH where } H = \{0, 4\} \subseteq S \text{ be the subset subsemiring of } S\}.$

$P = \{\text{subsets from } \{0, a_8, a_{10}, a_9\} \{g_0, g_2\}\}, L\{g_4, g_6\}, L\{g_6, g_8\} \subseteq S \text{ is a set subset semiring ideal of the subset semiring over the subset subsemiring } M \text{ of } S. \text{ (Here } g_i = i \text{ for } i = 0, 1, 2, \dots, 9).$

**Example 2.45:** Let  $S = \{\text{Collection of all subsets of the groupoid lattice};$

LG where L is



and G is a groupoid given by the following table;

*	$g_0$	$g_1$	$g_2$	$g_3$
$g_0$	$g_0$	$g_2$	$g_0$	$g_2$
$g_1$	$g_1$	$g_3$	$g_1$	$g_3$
$g_2$	$g_2$	$g_0$	$g_2$	$g_0$
$g_3$	$g_3$	$g_1$	$g_3$	$g_1$

be the subset non associative semiring of the groupoid lattice LG.

Take  $M = \{\text{Subsets of the subgroupoid lattice LH where } H = \{a_0, a_2\} \subseteq S \text{ to be a subset non associative subsemiring of } S.$

$P = \{\text{subsets of the } \{a_4, 0, a_3\}G\} = \{\sum a_i g_i \mid a_i \in \{0, a_4, a_3\} g_i \in G\} \subseteq S$  be a subset of S.

P is a set subset ideal of S over the subset subsemiring.

**Example 2.46:** Let  $S = \{\text{Collection of all subsets of the groupoid semiring } (Z^+ \cup \{0\})G \text{ where } G \text{ is the groupoid given by the following table;}$

*	$a_0$	$a_1$	$a_2$	$a_3$	$a_4$	$a_5$	$a_6$
$a_0$	$a_0$	$a_4$	$a_1$	$a_5$	$a_2$	$a_6$	$a_3$
$a_1$	$a_3$	$a_0$	$a_4$	$a_1$	$a_5$	$a_2$	$a_6$
$a_2$	$a_6$	$a_3$	$a_0$	$a_4$	$a_4$	$a_5$	$a_2$
$a_3$	$a_2$	$a_6$	$a_3$	$a_0$	$a_4$	$a_1$	$a_5$
$a_4$	$a_5$	$a_2$	$a_6$	$a_3$	$a_0$	$a_4$	$a_1$
$a_5$	$a_1$	$a_5$	$a_2$	$a_6$	$a_3$	$a_0$	$a_4$
$a_6$	$a_4$	$a_1$	$a_5$	$a_2$	$a_6$	$a_3$	$a_0$

be the subset non associative semiring.

Let  $M = \{\text{collection of all subsets of the groupoid semiring } (3Z^+ \cup \{0\})G\} \subseteq S$  be the subset non associative subsemiring.

$P = \{\text{Subsets of } (2Z^+ \cup \{0\})G, (7Z^+ \cup \{0\})G, (23Z^+ \cup \{0\})G\} \subseteq S$  is a subset semiring set ideal of the subset non associative semiring over the subset subsemiring M of S.

Now we have seen examples of subset semiring set ideal topological spaces of subset semirings over a subset subsemiring over S.

The advantage of defining subset semiring ideal topological spaces is that we can have several subset semiring ideal topological spaces for a given subset semiring depending on the subset subsemiring.

We suggest the following problems for this chapter.

**Problems:**

1. Find some special properties enjoyed by subset non associative semirings.
2. Let  $S = \{ \text{Collection of all subsets of the groupoid ring } Z_{15}G \text{ where } G \text{ is the groupoid given by the following table;}$

*	0	$g_1$	$g_2$	$g_3$	$g_4$	$g_5$	$g_6$	$g_7$	$g_8$
0	0	$g_4$	$g_8$	$g_3$	$g_7$	$g_2$	$g_6$	$g_1$	$g_5$
$g_1$	$g_4$	$g_8$	$g_3$	$g_7$	$g_2$	$g_6$	$g_1$	$g_5$	0
$g_2$	$g_8$	$g_3$	$g_7$	$g_2$	$g_6$	$g_1$	$g_5$	0	$g_4$
$g_3$	$g_3$	$g_7$	$g_2$	$g_6$	$g_1$	$g_5$	0	$g_4$	$g_8$
$g_4$	$g_7$	$g_2$	$g_6$	$g_1$	$g_5$	0	$g_4$	$g_8$	$g_3$
$g_5$	$g_2$	$g_6$	$g_1$	$g_5$	0	$g_4$	$g_8$	$g_3$	$g_7$
$g_6$	$g_6$	$g_1$	$g_5$	0	$g_4$	$g_8$	$g_3$	$g_7$	$g_2$
$g_7$	$g_1$	$g_5$	0	$g_4$	$g_8$	$g_3$	$g_7$	$g_2$	$g_6$
$g_8$	$g_5$	0	$g_4$	$g_8$	$g_3$	$g_7$	$g_2$	$g_6$	$g_1$

be the subset semiring of the groupoid ring  $Z_{15}G$ .

- (i) Find  $o(S)$ .
- (ii) Can  $S$  have subset zero divisors?
- (iii) Can  $S$  have subset idempotents?
- (iv) Can  $S$  have subset  $S$ -zero divisors?
- (v) Can  $S$  have subset  $S$ -idempotents?
- (vi) Is  $S$  commutative?
- (vii) Can this  $S$  be inner commutative?

3. Let  $S = \{\text{Collection of all subsets of the groupoid ring } Z_{11}G$  where  $G$  is given by the following table;

*	$g_0$	$g_1$	$g_2$	$g_3$	$g_4$	$g_5$	$g_6$	$g_7$
$g_0$	$g_0$	$g_1$	$g_2$	$g_3$	$g_4$	$g_5$	$g_6$	$g_7$
$g_1$	$g_1$	$g_0$	$g_5$	$g_2$	$g_6$	$g_3$	$g_7$	$g_4$
$g_2$	$g_2$	$g_5$	$g_0$	$g_6$	$g_3$	$g_7$	$g_4$	$g_1$
$g_3$	$g_3$	$g_2$	$g_6$	$g_0$	$g_7$	$g_4$	$g_1$	$g_5$
$g_4$	$g_4$	$g_6$	$g_3$	$g_7$	$g_0$	$g_1$	$g_5$	$g_2$
$g_5$	$g_5$	$g_3$	$g_7$	$g_4$	$g_1$	$g_0$	$g_2$	$g_6$
$g_6$	$g_6$	$g_7$	$g_4$	$g_1$	$g_5$	$g_2$	$g_0$	$g_3$
$g_7$	$g_7$	$g_4$	$g_1$	$g_5$	$g_2$	$g_6$	$g_3$	$g_0$

be the subset semiring of  $Z_{11}G$ .

Study questions (i) to (vii) of problem 2 for this  $S$ .

4. Let  $S = \{\text{Collection of all subsets of the groupoid ring } PG$  where  $P =$

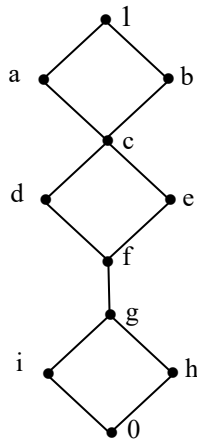

and  $G$  is given by the following table;

*	0	g <sub>1</sub>	g <sub>2</sub>	g <sub>3</sub>	g <sub>4</sub>	g <sub>5</sub>
0	0	g <sub>5</sub>	g <sub>4</sub>	g <sub>3</sub>	g <sub>2</sub>	g <sub>1</sub>
g <sub>1</sub>	g <sub>5</sub>	g <sub>4</sub>	g <sub>3</sub>	g <sub>2</sub>	g <sub>1</sub>	0
g <sub>2</sub>	g <sub>4</sub>	g <sub>3</sub>	g <sub>2</sub>	g <sub>1</sub>	0	g <sub>5</sub>
g <sub>3</sub>	g <sub>3</sub>	g <sub>2</sub>	g <sub>1</sub>	0	g <sub>5</sub>	g <sub>4</sub>
g <sub>4</sub>	g <sub>2</sub>	g <sub>1</sub>	0	g <sub>5</sub>	g <sub>4</sub>	g <sub>3</sub>
g <sub>5</sub>	g <sub>1</sub>	0	g <sub>5</sub>	g <sub>4</sub>	g <sub>3</sub>	g <sub>2</sub>

be the subset semiring of the groupoid lattice LG.

- (i) Find subset zero divisors in S?
  - (ii) Can S have subset idempotents?
  - (iii) Can S have subset semiring left ideals which are not subset right semiring ideals?
  - (iv) Does S contain subset right ideals which are not left subset semiring ideals?
  - (v) Does S contain subset subsemirings which are not Subset semiring ideals?
  - (vi) Is  $o(S) < \infty$ ?
  - (vii) Can S have subset nilpotent elements?
5. Let  $S = \{\text{collection of all subsets from the groupoid ring } RG \text{ where } G \text{ is a groupoid as in problem 4 and } R \text{ is the ring } Z_{42}\}$  be the subset semiring of  $Z_{42}G$ .

Study questions (i) to (vii) of problem 4 for this S.

6. Let  $S_1 = \{\text{Collection of all subsets from the groupoid lattice ring } LG; G \text{ is the groupoid given in problem 4 and } L \text{ is a chain lattice which is as follows:}$

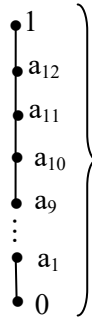

be the subset semiring of LG.

Study questions (i) to (vii) problem of 4 for this  $S_1$ .

7. Let  $S_2 = \{ \text{Collection of all subsets of the groupoid semiring LG where L is as follows and G is given in problem 3; } \}$

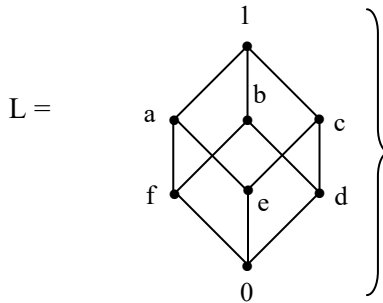

be the subset semiring of LG.

Study questions (i) to (vii) of problem 4 for this  $S_2$ .

8. Let  $S_3 = \{ \text{Collection of all subsets of the groupoid ring } Z_{11}G \text{ where G is given by the following table; } \}$



*	0	$g_1$	$g_2$	$g_3$	$g_4$	$g_5$	$g_6$	$g_7$
0	0	$g_6$	$g_4$	$g_2$	0	$g_6$	$g_4$	$g_2$
$g_1$	$g_2$	0	$g_6$	$g_4$	$g_2$	0	$g_6$	$g_4$
$g_2$	$g_4$	$g_2$	0	$g_6$	$g_4$	$g_2$	0	$g_6$
$g_3$	$g_6$	$g_4$	$g_2$	0	$g_6$	$g_4$	$g_2$	0
$g_4$	0	$g_6$	$g_4$	$g_2$	0	$g_6$	$g_4$	$g_2$
$g_5$	$g_2$	0	$g_6$	$g_4$	$g_2$	0	$g_6$	$g_4$
$g_6$	$g_4$	$g_2$	0	$g_6$	$g_4$	$g_2$	0	$g_6$
$g_7$	$g_6$	$g_4$	$g_2$	0	$g_6$	$g_4$	$g_2$	0

be the subset semiring of the groupoid ring  $Z_{11}G$ .  
 Study questions (i) to (vii) of problem 4 for this  $S_3$ .

9. Let  $S = \{\text{Collection of all subsets of the groupoid ring } Z_{48}G \text{ where } G \text{ is an in problem (8)}\}$  be the subset semiring of the groupoid ring  $Z_{48}G$ .

- (i) Study questions (i) to (vii) of problem four of this S.
- (ii) Find S semiring ideals if any in S.

10. Let  $S = \{\text{Collection of all subsets of the groupoid lattice } LG \text{ where } G \text{ is as in problem 8 and } L \text{ is the given in the following};$

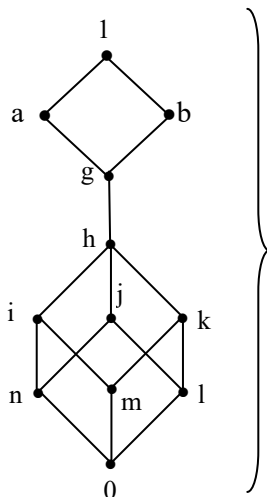

be the subset semiring of the groupoid lattice LG.  
 Study questions (i) to (vii) of problem 4 for this S.

11. Let  $S = \{\text{collection of all subsets of the lattice groupoid LG where } L = L_1 \times L_2 \text{ where}$

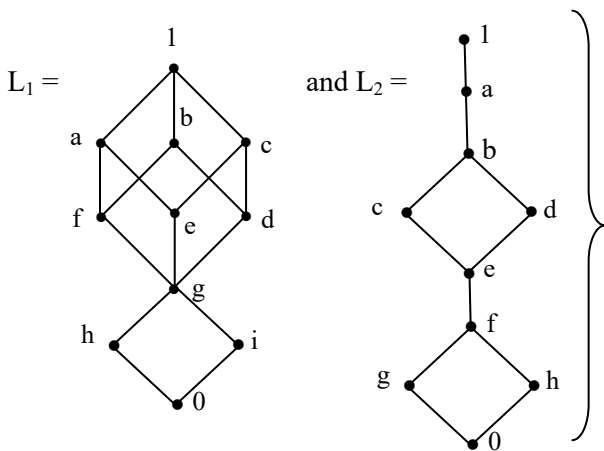

and G is the groupoid given in the following;

*	0	$g_1$	$g_2$	$g_3$	$g_4$	$g_5$	$g_6$	$g_7$	$g_8$	$g_9$
0	0	$g_5$	0	$g_5$	0	$g_5$	0	$g_5$	0	$g_5$
$g_1$	$g_1$	$g_6$	$g_1$	$g_6$	$g_1$	$g_6$	$g_1$	$g_6$	$g_1$	$g_6$
$g_2$	$g_2$	$g_7$	$g_2$	$g_7$	$g_2$	$g_7$	$g_2$	$g_7$	$g_2$	$g_7$
$g_3$	$g_3$	$g_8$	$g_3$	$g_8$	$g_3$	$g_8$	$g_3$	$g_8$	$g_3$	$g_8$
$g_4$	$g_4$	$g_9$	$g_4$	$g_9$	$g_4$	$g_9$	$g_4$	$g_9$	$g_4$	$g_9$
$g_5$	$g_5$	0	$g_5$	0	$g_5$	0	$g_5$	0	$g_5$	0
$g_6$	$g_6$	$g_1$	$g_6$	$g_1$	$g_6$	$g_1$	$g_6$	$g_1$	$g_6$	$g_1$
$g_7$	$g_7$	$g_2$	$g_7$	$g_2$	$g_7$	$g_2$	$g_7$	$g_2$	$g_7$	$g_2$
$g_8$	$g_8$	$g_3$	$g_8$	$g_3$	$g_8$	$g_3$	$g_8$	$g_3$	$g_8$	$g_3$
$g_9$	$g_9$	$g_4$	$g_9$	$g_4$	$g_9$	$g_4$	$g_9$	$g_4$	$g_9$	$g_4$

be the subset non associative semiring of the lattice groupoid LG.

- (i) Find  $o(S)$ .
- (ii) Find subset zero divisors in  $S$ .
- (iii) Find subset idempotents in  $S$ .
- (iv) Can  $S$  have  $S$ -subset zero divisors?
- (v) Can  $S$  have subset  $S$ -ideals?
- (vi) Can  $S$  have  $S$ -subset subsemirings which are not subset  $S$ -ideals?
- (vii) Can  $S$  have only  $S$ -subset left semiring ideals which are not subset semiring right ideals?
- (viii) Give a subset  $S$ -right semiring ideal which is not a subset left semiring ideal.

12. Let  $S = \{\text{Collection of all subsets of the groupoid ring } (Z_3 \times Z_9)G \text{ where } G \text{ is given in problem 11}\}$  be the subset semiring.

Study questions (i) to (viii) of problem 11 for this  $S$ .

13. Let  $S = \{\text{Collection of all subsets of the groupoid ring } (Z_5 \times Z_7 \times Z_{19})G, \text{ where } G \text{ is a groupoid given in problem 11}\}$  be the subset semiring.

Study questions (i) to (viii) of problems 11 for this  $S$ .

14. Let  $S = \{\text{Collection of all subsets of the groupoid semiring } (Z^+ \cup \{0\})G, \text{ where } G \text{ is the groupoid given in problem 11}\}$  be the subset semiring of the groupoid semiring  $(Z^+ \cup \{0\})G$ .

- (i) Is  $S$  commutative?
- (ii) Can  $S$  be a  $S$ -subset semiring?
- (iii) Can  $S$  have subset zero divisors?
- (iv) Can  $S$  have subset zero divisors which are not subset  $S$ -zero divisors?
- (v) Can  $S$  have subset  $S$ -idempotents?
- (vi) Can  $S$  have subset  $S$ -subset ideals?
- (vii) Is it possible for  $S$  to have right  $S$ -subset semiring ideals which are not subset semiring left ideals?

- (viii) Can  $S$  have subset semiring ideals which are not  $S$ -subset semiring ideals?
- (ix) Give a  $S$ -subset subsemiring which is not a  $S$ -subset semiring ideal.

15. Let  $S = \{\text{Collection of all subsets of the groupoid ring } ZG \text{ for } G \text{ given in problem (11)}\}$  be the subset semiring.

Study questions (i) to (ix) of problems 14 for this  $S$ .

16. Let  $S = \{\text{Collection of all subsets of the groupoid ring } Z_{10}G \text{ where } G = G_1 \times G_2 \text{ groupoid given below the table of } G_1;\}$

*	X <sub>0</sub>	X <sub>1</sub>	X <sub>2</sub>	X <sub>3</sub>	X <sub>4</sub>	X <sub>5</sub>	X <sub>6</sub>	X <sub>7</sub>
X <sub>0</sub>	X <sub>0</sub>	X <sub>6</sub>	X <sub>4</sub>	X <sub>2</sub>	X <sub>0</sub>	X <sub>6</sub>	X <sub>4</sub>	X <sub>2</sub>
X <sub>1</sub>	X <sub>2</sub>	X <sub>0</sub>	X <sub>6</sub>	X <sub>4</sub>	X <sub>2</sub>	X <sub>0</sub>	X <sub>6</sub>	X <sub>4</sub>
X <sub>2</sub>	X <sub>4</sub>	X <sub>2</sub>	X <sub>0</sub>	X <sub>6</sub>	X <sub>4</sub>	X <sub>2</sub>	X <sub>0</sub>	X <sub>6</sub>
X <sub>3</sub>	X <sub>6</sub>	X <sub>4</sub>	X <sub>2</sub>	X <sub>0</sub>	X <sub>6</sub>	X <sub>4</sub>	X <sub>2</sub>	X <sub>0</sub>
X <sub>4</sub>	X <sub>0</sub>	X <sub>6</sub>	X <sub>4</sub>	X <sub>2</sub>	X <sub>0</sub>	X <sub>6</sub>	X <sub>4</sub>	X <sub>2</sub>
X <sub>5</sub>	X <sub>2</sub>	X <sub>0</sub>	X <sub>6</sub>	X <sub>4</sub>	X <sub>2</sub>	X <sub>0</sub>	X <sub>6</sub>	X <sub>4</sub>
X <sub>6</sub>	X <sub>4</sub>	X <sub>2</sub>	X <sub>0</sub>	X <sub>6</sub>	X <sub>4</sub>	X <sub>2</sub>	X <sub>0</sub>	X <sub>6</sub>
X <sub>7</sub>	X <sub>6</sub>	X <sub>4</sub>	X <sub>2</sub>	X <sub>0</sub>	X <sub>0</sub>	X <sub>4</sub>	X <sub>2</sub>	X <sub>0</sub>

and the table of  $G_2$  is as follows:

*	0	g <sub>1</sub>	g <sub>2</sub>	g <sub>3</sub>	g <sub>4</sub>	g <sub>5</sub>
0	0	g <sub>5</sub>	g <sub>4</sub>	g <sub>3</sub>	g <sub>2</sub>	g <sub>1</sub>
g <sub>1</sub>	g <sub>2</sub>	g <sub>1</sub>	0	g <sub>5</sub>	g <sub>4</sub>	g <sub>3</sub>
g <sub>2</sub>	g <sub>4</sub>	g <sub>3</sub>	g <sub>2</sub>	g <sub>1</sub>	0	g <sub>5</sub>
g <sub>3</sub>	0	g <sub>5</sub>	g <sub>4</sub>	g <sub>3</sub>	g <sub>2</sub>	g <sub>1</sub>
g <sub>4</sub>	g <sub>2</sub>	g <sub>1</sub>	0	g <sub>5</sub>	g <sub>4</sub>	g <sub>3</sub>
g <sub>5</sub>	g <sub>4</sub>	g <sub>3</sub>	g <sub>2</sub>	g <sub>1</sub>	0	g <sub>5</sub>

be the subset semiring.

- (i) Prove  $S$  is non associative.
- (ii) Is  $S$  non commutative?
- (iii) Find subset zero divisors if any in  $S$ .
- (iv) Can  $S$  have  $S$  subset ideals?
- (v) Find  $o(S)$ .
- (vi) Can  $S$  have  $S$ -subset subsemirings which are not subset semiring ideals of  $S$ ?
- (vii) Is  $S$  a  $S$ -subset semiring?
- (viii) Obtain any other special feature enjoyed by  $S$ .

17. Let  $S = \{\text{Collection of all subsets of the groupoid ring } (Z_{19} \times Z_3 \times Z_8) (G_1 \times G_2); G_1 \times G_2 \text{ given in problem 16}\}$  be the subset semiring.

- (i) Find the special features enjoyed by  $S$ .
- (ii) Study questions (i) to (viii) of problem 16 for this  $S$ .

18. Let  $S = \{\text{Collection of all subsets of the groupoid semiring } L(G_1 \times G_2) \text{ where } L \text{ is the distributive lattice given by}$

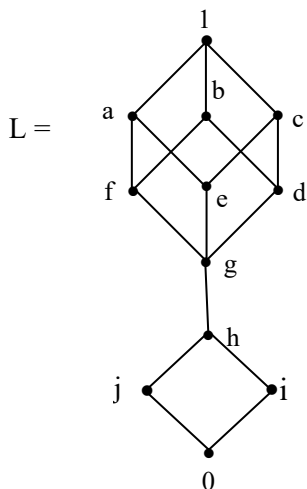

and  $G$  is the groupoid given in problem 16}.

Study questions (i) to (viii) of problem 16 for this  $S$ .

19. Does there exist a special subset non associative semifield?
20. Does there exist a subset non associative semiring  $S$  which has no subset zero divisors but only subset idempotents?
21. Does there exist a subset non associative semiring which has only subset idempotents but no subset zero divisors?
22. Find a subset non associative semiring which has only right subset semiring ideals and no left subset semiring ideals.
23. Does there exist a subset non associative semiring  $S$  in which  $S$  has only left subset semiring ideals and no right subset semiring ideals?
24. Give an example of a subset non associative semiring  $S$  which has only subset ideals and does not contain subset semiring right ideals or subset semiring left ideals. ( $S$  is a non commutative subset semiring).
25. Does there exist a subset non associative semiring which is not a Smarandache subset semiring?
26. Does there exist a Smarandache subset non associative semiring which has none of its subset subsemiring to be Smarandache?
27. Does there exist a Smarandache subset non associative semiring  $S$  which has subset semiring ideals but none of the subset semiring ideals of  $S$  is Smarandache?
28. Does there exist a Smarandache subset non associative semiring  $S$  in which every subset semiring ideal is Smarandache?

29. Give an example of subset non associative semiring which has subset  $S$ -zero divisors?
30. Does there exist a non associative subset Smarandache semiring in which every subset zero divisor is a subset  $S$ -zero divisor?
31. Does there exist a subset non associative semiring in which no subset zero divisor is a subset  $S$ -zero divisor?
32. Give an example of a subset non associative semiring which has subset  $S$ -idempotents?
33. Does there exist a subset non associative semiring in which every subset idempotent is a Smarandache subset idempotent?
34. Give an example of a subset non associative semiring of finite order which is not Smarandache.
35. Give an example of a non associative semiring of infinite order in which;
  - (i) All subset idempotents are subset  $S$ -idempotents.
  - (ii) All subset zero divisors are subset  $S$ -zero divisors.
36. Does there exist a subset non associative semiring of order 143?
37. Can a subset non associative semiring contain a proper subset field?
38. Give an example of a finite subset non associative semiring in which every element is a subset idempotent.
39. Does there exist a subset non associative semiring such that every element is subset nilpotent?

40. Give an example of a subset non associative semiring which satisfies the subset right alternative law but not the subset left alternative law.
41. Give an example of a subset non associative semiring which satisfies the Bol identity.
42. Give an example of a subset non associative semiring which satisfies the Moufang identity.
43. Does there exist a subset non associative semiring which does not satisfy any of the standard identities?
44. If  $G$  is a Moufang groupoid will  $ZG$  be a Moufang groupoid ring?
45. Can one say the subset  $S$  of a groupoid ring  $ZG$  where  $G$  is a Bol groupoid be a subset non alternative semiring?
46. Give an example of a subset non associative semiring which satisfies left alternative identity but not the right alternative identity.
47. Does there exist a subset non associative semiring which satisfies all the three identities viz., Moufang, Bol and alternative?
48. Give an example of a subset non associative semiring  $S$  in which no subset subsemiring is a  $S$ -right ideal of  $S$ .
49. Let  $S = \{\text{Collection of all subsets of the groupoid lattice } LG \text{ where } G = \{Z_{40}, *, (3, 10)\}\}$  be the subset non associative semiring of the groupoid lattice  $LG$ . The lattice  $L$  is as follows:



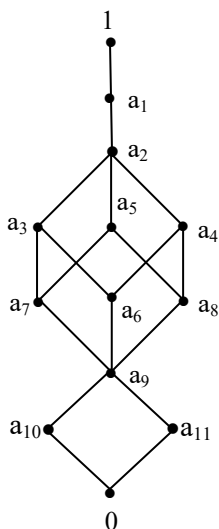

- (i) Find  $o(S)$ ?
- (ii) Is  $S$  a Smarandache subset semiring?
- (iii) Prove  $S$  has subset zero divisors?
- (iv) Can  $S$  have subset idempotents?
- (v) Prove  $S$  has subset subsemiring which is not a  $S$ -subset semiring ideal.
- (vi) Can  $S$  have a subset semiring ideal which is not a  $S$ -subset semiring ideal?
- (vii) Can  $S$  have subset subsemirings which are not  $S$ -subset subsemirings?

50. Let  $S$  be a subset non associative semiring of the groupoid ring  $Z_{18}G$  where  $G = \{Z_{24}, *, (8, 3)\}$ .

Study question (i) to (vii) of problem (49) in case of this  $S$ .

51. Let  $S = \{\text{Collection of all subset of the groupoid ring } LG \text{ where } L \text{ is the lattice}\}$

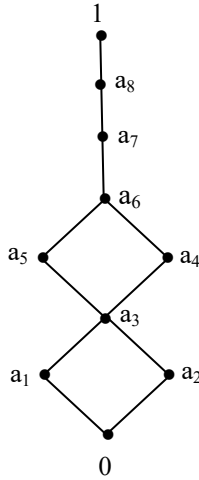

and  $G = \{Z_{48}, *, (2, 0)\}$  be the subset non associative semiring of LG.

Study questions (i) to (viii) of problem (49) in case of this S.

52. Let  $S = \{\text{Collection of all subsets of the groupoid ring LG where } L =$

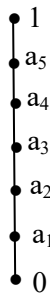

and  $G = \{Z_{19}, *, (1,2)\}$  be subset semiring of the groupoid lattice LG.

Study questions (i) to (vii) of problem 49 in case of this S.

53. Let  $S = \{\text{Collection of all subsets of the groupoid ring } Z_{41}G \text{ where } G = \{Z_{43}, *, (0, 13)\}\}$  be the subset semiring of the groupoid ring  $Z_{41}G$ .

Study questions (i) to (vii) of problem 49 in case of this  $S$ .

54. Compare the subset non associative semirings given in problems 52 and 53.
55. Let  $S = \{\text{Collection of all subsets of the groupoid ring } LG \text{ where } L =$

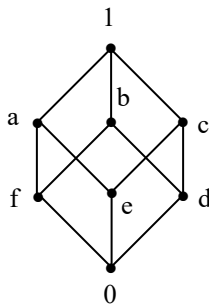

and  $G = \{Z_{12}, *, (4, 2)\}$  be the subset semiring.

Study questions (i) to (vii) of problem 49 in case of this  $S$ .

56. If  $L$  in problem 55 is replaced by  $R = Z_{42}$  study questions (i) to (vii) of problem 49 and compare both the subset semirings.
57. Let  $S = \{\text{Collection of all subsets of the groupoid lattice } LG \text{ where } L =$

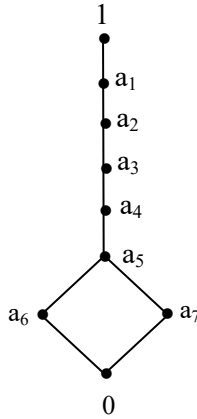

and  $G = \{Z_{12}, *, (4, 3)\}$  be the groupoid} be the subset non associative semiring of the groupoid lattice LG.

- (i) Can S have subset semiring ideals?
  - (ii) Can S have subset S-right semiring ideals which are not subset semiring left ideals?
  - (iii) Can S have S-subset semiring ideals?
  - (iv) Can S have S-subset left semiring semiideals which are not S-subset semiring right semiideals?
  - (v) Can S have S-strong semiring left semiideals?
58. Does there exist a subset non associative semiring which has no subset left or right subset semiring semiideals.
59. Give an example of a subset semiring which has only left subset semiring semiideal and no right subset semiring semiideals.
60. Give an example of a subset non associative semiring in which every left subset semiring semiideal which is also a right subset semiring semiideal.
61. Distinguish between the subset non associative semirings which has subset semiring semiideal and those that subset semirings which has no strong subset semiring semiideals.

62. Obtain some special features enjoyed by the subset non associative semirings which has no strong subset semiring right or subset semiring left semiideals.
63. Give some distinct features enjoyed by subset non associative semiring and subset non associative semifield.
64. Characterize those subset non associative semirings which has no S-subset semiring semiideals (right or left).
65. Does their exist a subset non associative semiring which has Smarandache strong subset semiring right semiideals but does not contain any Smarandache strong subset semiring left semiideals?
66. Give an example of a Smarandache strong semiideal of a non associative subset semiring S. Let  $S = \{\text{Collection of all subsets of the groupoid semiring } LG \text{ where } L =$

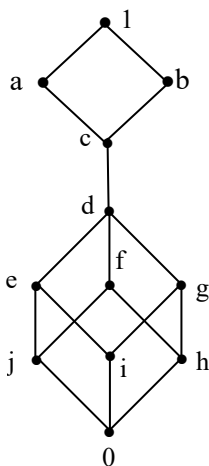

and G is a groupoid given by the following table;

*	e	g <sub>1</sub>	g <sub>2</sub>	g <sub>3</sub>	g <sub>4</sub>	g <sub>5</sub>	g <sub>6</sub>
e	e	g <sub>1</sub>	g <sub>2</sub>	g <sub>3</sub>	g <sub>4</sub>	g <sub>5</sub>	g <sub>6</sub>
g <sub>1</sub>	g <sub>1</sub>	e	g <sub>4</sub>	g <sub>2</sub>	g <sub>1</sub>	g <sub>4</sub>	g <sub>2</sub>
g <sub>2</sub>	g <sub>2</sub>	g <sub>3</sub>	e	g <sub>5</sub>	g <sub>4</sub>	g <sub>2</sub>	g <sub>1</sub>
g <sub>3</sub>	g <sub>3</sub>	g <sub>4</sub>	g <sub>1</sub>	e	g <sub>5</sub>	g <sub>6</sub>	g <sub>2</sub>
g <sub>4</sub>	g <sub>4</sub>	g <sub>3</sub>	g <sub>5</sub>	g <sub>1</sub>	e	g <sub>2</sub>	g <sub>6</sub>
g <sub>5</sub>	g <sub>5</sub>	g <sub>4</sub>	g <sub>2</sub>	g <sub>6</sub>	g <sub>3</sub>	e	g <sub>1</sub>
g <sub>6</sub>	g <sub>6</sub>	g <sub>1</sub>	g <sub>2</sub>	g <sub>5</sub>	g <sub>5</sub>	g <sub>4</sub>	e

be the subset non associative semiring.

- (i) Can S have S-left subset semiring semiideals?
- (ii) Can S have S right subset semiring semiideals?
- (iii) Can S have right subset semiring ideals which are not S-subset semiring semiideals?
- (iv) Can S have strong left semiring subset semiring semiideals?
- (v) Can S have S-subset semiring left or right semiring semiideals?

67. Let  $S = \{\text{Collection of all subsets of the groupoid ring } Z_4G \text{ where } G = \{Z_{20}, *, (10, 3)\}\}$  be the subset non associative semiring of the groupoid ring  $Z_4G$ .

Study questions (i) to (v) of problem 66 for this S.

68. Let  $S = \{\text{Collection of all subsets of the groupoid lattice; } LG \text{ where } L =$

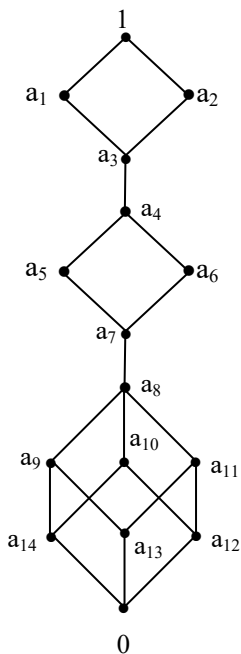

and  $G = \{Z_6, *, (3, 0)\}$  be the groupoid} be the subset non associative semiring of the lattice groupoid LG.

Study questions (i) to (v) of problem 66 for this S.

69. Is S given in problem 68 a S-strong subset regular semiring?
70. Can S given in problem 68 be S-quasi commutative?
71. Give an example of a subset Smarandache commutative subset semiring.
72. Give an example of a subset non associative semiring S which is a Smarandache subset semi normal subring of S.

73. Give an example of a Smarandache strongly commutative subset non commutative semiring.
74. Give an example of a Smarandache generalized subset left semiring semiideal of a subset non associative semiring.
75. Give an example of a strong subset left semiring semiideal of the subset non associative semiring.
76. Let  $S$  be the subset non associative semiring.  
Can  $S$  be a subset  $J$ -semiring.
77. Does there exist a subset non associative semiring which is a subset  $Lin$  semiring?
78. Does there exist a subset non associative semiring which is a subset pre  $J$ -semiring?
79. Does there exist a subset non associative semiring which is a subset  $E$  semiring?
80. Can  $S$  the subset non associative semiring be a  $S$ -zero square subset semiring?
81. Does there exist a subset non associative semiring  $S$  which is a zero square subset semiring?
82. Find a subset non associative semiring  $S$  in which every element generates a subset closed net.
83. Does there exist a subset non associative semiring which is a subset  $Lin$  semiring?
84. Describe the special features enjoyed by the subset non associative semiring which is a subset pre  $J$ -ring.



85. Give an example of a subset non associative semiring which is a subset pre J-ring.
86. Give an example of a subset non associative semiring which is a Smarandache subset pre J-ring.
87. Compare the subset non associative semirings given in problems 86 and 85.
88. Give an example of subset non associative semiring which is a S- subset E-semiring.
89. Does there exists a subset non associative semiring which is a subset E-semiring?
90. Enumerate the special features associated with subst non associative semiring which is a subset E-semiring.
91. What are the special properties enjoyed by a subset non associative semiring which is a subset P-ring?
92. Give an example of a subset non associative semiring which is a subset zero square ring.
93. Give an example of a subset non associative semiring which is a subset S-zero square ring.
94. Give an example of a subset non associative semiring which is a subset  $\gamma_n$ -ring.
95. What are the special properties associated with a subset non associative semiring which is a subset  $\gamma_n$ -ring?
96. If the subset non associative semiring of a groupoid ring RG is a subset  $\gamma_n$ -ring, can G be a Moufang groupoid?
97. Give an example of a subset non associative semiring of a groupoid ring which is a subset strong regular ring.



be the subset semiring of the groupoid ring  $Z_6G$ .

- (i) Let  $P = \{\text{Collection of all subset ideals of } S\}$ . Prove  $\{P, \cup, \cap\}$  and  $\{P, \cup_n, \cap_n\}$  are two distinct subset topological semiring ideal spaces of the subset semiring.
- (ii) Let  $M = \{\text{Collection of all subset of the groupoid lattice } LG \text{ where } L \text{ is lattice which is as follows:}$

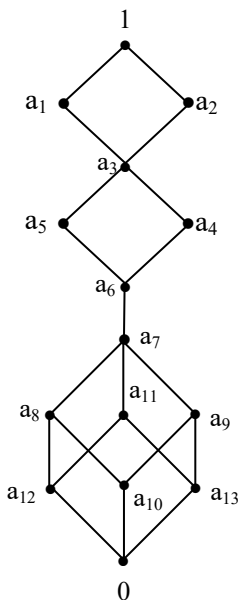

and  $G = \{Z_{12}, *, (4, 3)\}$  be the groupoid} be the subset non associative semiring.

- (i) Let  $P = \{\text{Collection of all subset subsemiring of } S\}$ ; find  $(P', \cup, \cap)$  and  $(P, \cup_n, \cap_n)$ .
- (ii) Find  $o(P)$ .
- (iii)  $M = \{\text{Collection of all subset ideals of } S\}$ ; find  $(M', \cup, \cap)$  and  $(M, \cup_n, \cap_n)$  and find  $o(M)$ .
- (iv) Compare  $M$  and  $P$ .

103. Let  $S = \{\text{Collection of all subsets of the groupoid ring } Z_7G \text{ where } G = \{Z_8, *, (4, 6)\}\}$  be the subset semiring.

- (i) Let  $M = \{\text{Collection of all subset subsemirings of } S\}$ . Find  $o(M)$  and show  $(M', \cup, \cap)$  and  $(M, \cup_n, \cap_n)$  are two different subset topological spaces of subset subsemirings of  $S$ .
- (ii)  $P = \{\text{Collection of all subset ideals of } S\}$ . Find  $o(S)$  and show  $(P', \cup, \cap)$  and  $(P, \cup_n, \cap_n)$  are two distinct topological subset semiring ideal topological spaces of  $S$  ( $\cup$  and  $\cup_n$  generates the smallest subset ideals).
- (iii) Compare  $P$  and  $M$ .
- (iv) Is  $o(P) > o(M)$  or  $o(M) > o(P)$ ?

104. Let  $S = \{\text{Collection of all subsets of the groupoid lattice } LG \text{ where } L =$

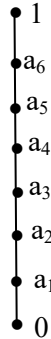

and  $G = \{Z_{16}, *, (4, 8)\}$  be the subset non associative subset semiring of the groupoid lattice  $LG$ .

- (i) Let  $P = \{\text{Collection of all subset subsemiring of } S\}$ . Find  $o(P)$  and find the subset topological subset subsemiring spaces of  $S$ ,  $(P', \cup, \cap)$  and  $(P, \cup_n, \cap_n)$  and compare  $(P, \cup_n, \cap_n)$  with  $(P', \cup, \cap)$ .

- (ii) Let  $M = \{\text{Collection of all subset semiring ideals of the subset semiring } S\}$ .
- (iii) Find  $o(M)$ . Compare the two subset semiring ideal topological spaces of the subset semiring  $S$ .
- (iv) Find  $o(M)$ . Compare  $(M, \cup, \cap)$  and  $(M, \cup_n, \cap_n)$ .

105. Let  $S = \{\text{Collection of all subsets of the groupoid ring } Z_{12}G \text{ where } G \text{ is given by } G = \{Z_{10}, *, (5, 0)\}\}$  be the subset semiring of the group ring  $Z_{12}G$ .

Study questions (i) and (iv) of problem 104 for this  $S$ .

106. Let  $S = \{\text{Collection of all subsets of the groupoid ring } Z_{15}G \text{ where } G \text{ is the groupoid } \{Z_7, *, (3, 1)\}\}$  be the subset semiring of the groupoid ring  $Z_{15}G$ .

- (i) Find  $o(S)$ .
- (ii) Find all subset subsemirings  $M$  of  $S$ .
- (iii) Find set subset semiring ideals of  $S$  over the subset subsemiring  $M_i \in M$ .

107. Let  $S = \{\text{Collection of all subsets of the groupoid lattice } LG \text{ where } L =$

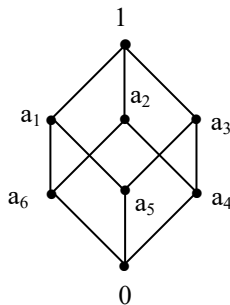

and  $G = \{Z_{18}, *, (9, 2)\}$  be the subset semiring of the groupoid lattice  $LG$ .

- (i) Find all the subset subsemiring  $M$  of  $S$ ; find  $o(M)$ .
- (ii) Find all set subset semiring ideal of  $S$  over  $M_i \in M$ .  
If  $P_i = \{\text{Collection of all set subset ideal semiring of } S \text{ over } M_i\}$  find  $o(P_i)$  for every  $i$ .
- (iii) Is  $(P_i, \cup, \cap)$  a set ideal semiring subset topological space of subset semirings of  $S$  over the subset semiring  $M_i$ ?
- (iv) Is  $(P_i, \cup_n, \cap_n)$  a subset set new semiring ideal topological space of subset semiring of  $S$  over  $M_i$ ?
- (v) Compare  $(P'_i, \cup, \cap)$  with  $(P_i, \cup_n, \cap_n)$ .

108. Let  $S = \{\text{Collection of all subsets of the groupoid lattice } LG \text{ of the lattice } L =$

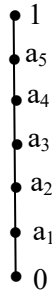

and  $G = \{Z_{12}, *, (4, 3)\}$  be the subset semiring of the groupoid lattice  $LG$ .

Study questions (i) to (v) of problem 107 for this  $S$ .

109. Let  $S = \{\text{Collection of all subsets of the groupoid semiring } (Z^+ \cup \{0\})G \text{ where } G = \{Z_{14}, *, (0, 7)\}\}$  be the subset semiring of the groupoid semiring  $(Z^+ \cup \{0\})G$ .

Study questions (i) to (v) of problem 107 for this  $S$ .

110. Let  $S = \{\text{Collection of all subsets of the groupoid ring } ZG\}$  be the subset semiring of the groupoid ring  $ZG$  where  $G = \{Z_{19}, *, (3, 0)\}$ .

Study questions (i) to (v) of problem 107 for this  $S$ .

111. Let  $S = \{\text{Collection of all subsets of the groupoid lattice } LG\}$  where  $L$  is a lattice given in the following and  $G = \{Z_{20}, *, (5, 0)\}$  where  $L =$

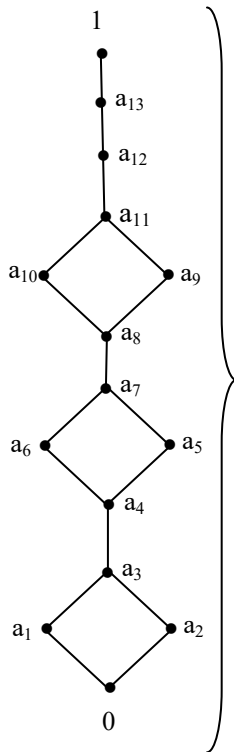

be the subset semiring of the groupoid lattice  $LG$ .

Study questions (i) to (v) of problem (107) for this  $S$ .

112. Let  $S = \{\text{Collection of all subsets of the groupoid ring } ZG \text{ where } G \text{ is the groupoid given by the following table};$

*	$\mathfrak{g}_0$	$\mathfrak{g}_1$	$\mathfrak{g}_2$	$\mathfrak{g}_3$	$\mathfrak{g}_4$	$\mathfrak{g}_5$	$\mathfrak{g}_6$	$\mathfrak{g}_7$	$\mathfrak{g}_8$	$\mathfrak{g}_9$	$\mathfrak{g}_{10}$	$\mathfrak{g}_{11}$
$\mathfrak{g}_0$	$\mathfrak{g}_0$	$\mathfrak{g}_4$	$\mathfrak{g}_8$	$\mathfrak{g}_0$	$\mathfrak{g}_4$	$\mathfrak{g}_8$	$\mathfrak{g}_0$	$\mathfrak{g}_4$	$\mathfrak{g}_8$	$\mathfrak{g}_0$	$\mathfrak{g}_4$	$\mathfrak{g}_8$
$\mathfrak{g}_1$	$\mathfrak{g}_3$	$\mathfrak{g}_7$	$\mathfrak{g}_{11}$	$\mathfrak{g}_3$	$\mathfrak{g}_7$	$\mathfrak{g}_{11}$	$\mathfrak{g}_3$	$\mathfrak{g}_7$	$\mathfrak{g}_{11}$	$\mathfrak{g}_3$	$\mathfrak{g}_7$	$\mathfrak{g}_{11}$
$\mathfrak{g}_2$	$\mathfrak{g}_6$	$\mathfrak{g}_{10}$	$\mathfrak{g}_2$	$\mathfrak{g}_6$	$\mathfrak{g}_{10}$	$\mathfrak{g}_2$	$\mathfrak{g}_6$	$\mathfrak{g}_{10}$	$\mathfrak{g}_2$	$\mathfrak{g}_6$	$\mathfrak{g}_{10}$	$\mathfrak{g}_2$
$\mathfrak{g}_3$	$\mathfrak{g}_9$	$\mathfrak{g}_1$	$\mathfrak{g}_5$	$\mathfrak{g}_9$	$\mathfrak{g}_1$	$\mathfrak{g}_5$	$\mathfrak{g}_9$	$\mathfrak{g}_1$	$\mathfrak{g}_5$	$\mathfrak{g}_9$	$\mathfrak{g}_1$	$\mathfrak{g}_5$
$\mathfrak{g}_4$	$\mathfrak{g}_0$	$\mathfrak{g}_4$	$\mathfrak{g}_8$	$\mathfrak{g}_0$	$\mathfrak{g}_4$	$\mathfrak{g}_8$	$\mathfrak{g}_0$	$\mathfrak{g}_4$	$\mathfrak{g}_8$	$\mathfrak{g}_0$	$\mathfrak{g}_4$	$\mathfrak{g}_8$
$\mathfrak{g}_5$	$\mathfrak{g}_3$	$\mathfrak{g}_7$	$\mathfrak{g}_{11}$	$\mathfrak{g}_3$	$\mathfrak{g}_7$	$\mathfrak{g}_{11}$	$\mathfrak{g}_3$	$\mathfrak{g}_7$	$\mathfrak{g}_{11}$	$\mathfrak{g}_3$	$\mathfrak{g}_7$	$\mathfrak{g}_{11}$
$\mathfrak{g}_6$	$\mathfrak{g}_6$	$\mathfrak{g}_{10}$	$\mathfrak{g}_2$	$\mathfrak{g}_6$	$\mathfrak{g}_{10}$	$\mathfrak{g}_2$	$\mathfrak{g}_6$	$\mathfrak{g}_{10}$	$\mathfrak{g}_2$	$\mathfrak{g}_6$	$\mathfrak{g}_{10}$	$\mathfrak{g}_2$
$\mathfrak{g}_7$	$\mathfrak{g}_9$	$\mathfrak{g}_1$	$\mathfrak{g}_5$	$\mathfrak{g}_9$	$\mathfrak{g}_1$	$\mathfrak{g}_5$	$\mathfrak{g}_9$	$\mathfrak{g}_1$	$\mathfrak{g}_5$	$\mathfrak{g}_9$	$\mathfrak{g}_1$	$\mathfrak{g}_5$
$\mathfrak{g}_8$	$\mathfrak{g}_0$	$\mathfrak{g}_4$	$\mathfrak{g}_8$	$\mathfrak{g}_0$	$\mathfrak{g}_4$	$\mathfrak{g}_8$	$\mathfrak{g}_0$	$\mathfrak{g}_4$	$\mathfrak{g}_8$	$\mathfrak{g}_0$	$\mathfrak{g}_4$	$\mathfrak{g}_8$
$\mathfrak{g}_9$	$\mathfrak{g}_3$	$\mathfrak{g}_7$	$\mathfrak{g}_{11}$	$\mathfrak{g}_3$	$\mathfrak{g}_7$	$\mathfrak{g}_{11}$	$\mathfrak{g}_3$	$\mathfrak{g}_7$	$\mathfrak{g}_{11}$	$\mathfrak{g}_3$	$\mathfrak{g}_7$	$\mathfrak{g}_{11}$
$\mathfrak{g}_{10}$	$\mathfrak{g}_6$	$\mathfrak{g}_{10}$	$\mathfrak{g}_2$	$\mathfrak{g}_6$	$\mathfrak{g}_{10}$	$\mathfrak{g}_2$	$\mathfrak{g}_6$	$\mathfrak{g}_{10}$	$\mathfrak{g}_2$	$\mathfrak{g}_6$	$\mathfrak{g}_{10}$	$\mathfrak{g}_2$
$\mathfrak{g}_{11}$	$\mathfrak{g}_9$	$\mathfrak{g}_1$	$\mathfrak{g}_5$	$\mathfrak{g}_9$	$\mathfrak{g}_1$	$\mathfrak{g}_5$	$\mathfrak{g}_9$	$\mathfrak{g}_1$	$\mathfrak{g}_5$	$\mathfrak{g}_9$	$\mathfrak{g}_1$	$\mathfrak{g}_5$

be the subset non associative semiring of the groupoid ring.

Study problem (i) to (v) of problem (107) for this S.

113. Let  $S = \{\text{Collection of all subset of the groupoid semiring } RG \text{ where } G = \{C(Z_{10}), *, (5, 2)\} \text{ and } R =$

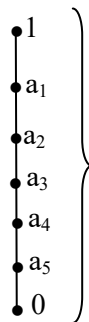



be the subset semiring of the groupoid semiring (lattice groupoid).

Study questions (i) to (v) of problem (107) for this S.

114. Let  $S = \{\text{Collection of all subsets of the groupoid ring } ZG \text{ where } G = \{C(Z_7)(g), *, (6g, 6i_F); g^2 = \{0\}\}$  be the complex modulo integer dual number groupoid} be the subset semiring.

Study questions (i) to (v) of problem (107) for this S.

115. Give an example of a subset semiring left semiideal of a subset non associative semiring.

116. Let  $S = \{\text{Collection of all subsets of the groupoid ring } Z_7G \text{ where } G = \{Z_6, *, (3, 0)\}$  be the subset semiring.

Does S contain S-generalized subset semiring semiideals?

## Chapter Three

# SUBSET NON ASSOCIATIVE SEMIRINGS USING LOOPS

In this chapter we introduce another special class of subset non associative semirings using loop rings. Study of this new type of subset non associative semirings is carried out in this chapter.

**DEFINITION 3.1:** *Let  $S = \{ \text{Collection of all subsets of the loop ring } RL \text{ of the loop } L \text{ over the ring } R \}$ .*

- (i) *Define for every  $A, B \in S$ ;  $A + B = \{a + b \mid a \in A, b \in B\}$ . Clearly  $A + B \in S$ .*
- (ii) *For every  $A, B \in S$  define  $A * B = \{a * b \mid a \in A \text{ and } b \in B \text{ and } * \text{ is a binary operation of } RL\}$ . We see  $A * B \in S$ .*
- (iii) *It is easily verified  $(A * B) * C \neq A * (B * C)$  in general for all  $A, B, C \in S$ .*

*Thus  $S$  is a non associative subset semiring of the loop ring  $RL$ .*

We will first illustrate this situation by some examples.

**Example 3.1:** Let

$S = \{\text{Collection of all subsets of the loop ring } Z_2L_5(3)\}$  be the subset non associative semiring of the loop ring  $Z_2L_5(3)$ . The loop associated with the loop ring  $Z_2L_5(3)$  is as follows:

*	e	g <sub>1</sub>	g <sub>2</sub>	g <sub>3</sub>	g <sub>4</sub>	g <sub>5</sub>
e	e	g <sub>1</sub>	g <sub>2</sub>	g <sub>3</sub>	g <sub>4</sub>	g <sub>5</sub>
g <sub>1</sub>	g <sub>1</sub>	e	g <sub>4</sub>	g <sub>2</sub>	g <sub>5</sub>	g <sub>3</sub>
g <sub>2</sub>	g <sub>2</sub>	g <sub>4</sub>	e	g <sub>5</sub>	g <sub>3</sub>	g <sub>1</sub>
g <sub>3</sub>	g <sub>3</sub>	g <sub>2</sub>	g <sub>5</sub>	e	g <sub>1</sub>	g <sub>4</sub>
g <sub>4</sub>	g <sub>4</sub>	g <sub>5</sub>	g <sub>3</sub>	g <sub>1</sub>	e	g <sub>2</sub>
g <sub>5</sub>	g <sub>5</sub>	g <sub>3</sub>	g <sub>1</sub>	g <sub>4</sub>	g <sub>2</sub>	e

Clearly this subset semiring of  $Z_2L_5(3)$  has subset units and subset zero divisors.

Take  $\{1 + g_2\} = A \in S$ . We see  $A^2 = \{0\}$  thus S has subset zero divisors.

Consider  $A_1 = \{1 + g_5\} \in S$ ; we have  $A_1^2 = \{0\}$  so is a subset zero divisor. Take  $A_2 = \{1 + g_1 + g_2 + g_3 + g_4 + g_5\} \in S$  we see  $A_2^2 = \{0\}$ .

This subset non associative semiring is commutative.

We take  $A = \{1 + g_1\}$  and  $B = \{1 + g_2\} \in S$  we see

$$\begin{aligned} A * B &= \{1 + g_1\} * \{1 + g_2\} \\ &= \{1 + g_1 + g_2 + g_1g_2\} \\ &= \{1 + g_1 + g_2 + g_4\}. \end{aligned}$$

Take  $C = \{1 + g_3\} \in S$ .

$$\begin{aligned} (A * B) * C &= \{1 + g_1 + g_2 + g_4\} * \{1 + g_3\} \\ &= \{1 + g_1 + g_2 + g_4 + g_3 + g_2 + g_5 + g_1\} \\ &= \{1 + g_4 + g_3 + g_5\} \quad \dots \quad I \end{aligned}$$

$$\begin{aligned}
 A * (B * C) &= A * (\{1 + g_2\} * \{1 + g_3\}) \\
 &= A * \{1 + g_2 + g_3 + g_5\} \\
 &= \{1 + g_1\} * \{1 + g_2 + g_3 + g_5\} \\
 &= \{1 + g_2 + g_3 + g_5 + g_1 + g_4 + g_2 + g_3\} \\
 &= \{1 + g_1 + g_4 + g_5\} \dots \quad \text{II}
 \end{aligned}$$

We see I and II are distinct so  $(A * B) * C \neq A * (B * C)$  for  $A, B, C \in S$ .

Let  $A = \{g_1 + g_2 + g_3 + g_4 + g_5\}$  and  $B = \{g_1 + g_2\} \in S$ .

$$\begin{aligned}
 A * B &= \{g_1 * g_1 + g_2 * g_1 + g_3 * g_1 + g_4 * g_1 + g_5 * g_1 + \\
 &\quad g_1 * g_2 + g_2 * g_2 + g_3 * g_2 + g_4 * g_2 + g_5 * g_2\} \\
 &= \{e + g_4 + g_2 + g_5 + g_3 + g_4 + e + g_5 + g_3 + g_1\} \\
 &= \{g_1 + g_2\} \\
 &= B \in S.
 \end{aligned}$$

**Example 3.2:** Let  $S = \{\text{Collection of all subsets of the loop ring ZL where L is the loop given by the following table;}$

*		e	a	b	c	d
e		e	a	b	c	d
a		a	e	c	d	b
b		b	d	a	e	c
c		c	b	d	a	e
d		d	c	e	b	a

be the non associative semiring of the loop ring ZL.

Clearly  $S$  is not a commutative subset subsemiring.

Further if  $A = \{e + c\}$  and  $B = \{e + a + b + c + d\} \in S$ .

$$\begin{aligned}
 \text{We find } A * B &= \{e * c\} * \{e + a + b + c + d\} \\
 &= \{e * e + e * a + e * b + e * c + e * d + c * e + c * a + \\
 &\quad c * b + c * c + c * d\}
 \end{aligned}$$

$$= \{e + a + b + c + d + c + b + d + a + e\}$$

$$= \{2(e + a + b + c + d)\} \in S.$$

**Example 3.3:** Let

$S = \{\text{Collection of all subsets of the loop ring } Z_2L_{21}(5)\}$  be the subset non associative semiring of the loop ring  $Z_2L_{21}(5)$ .

Let  $M_1 = \{\text{Collection of all subsets of the subloop ring } Z_2H_1(7) = Z_2\{e, 1, 8, 15\}\} \subseteq S$ ;  $M_1$  is a subset non associative subsemiring of  $S$ .

Let  $M_2 = \{\text{Collection of all subsets of the subloop ring } Z_2H_2(3) = Z_2\{e, 2, 5, 8, 11, 14, 17, 20\}\} \subseteq S$  be the subset subsemiring of  $S$ .

$M_3 = \{\text{Collection of all subsets of the subloop ring } Z_2H_3(3) = Z_2\{e, 3, 6, 9, 12, 15, 18, 21\}\} \subseteq S$  be the subset subsemiring of  $S$ .

$P_1 = \{\text{Collection of all subsets of the subloop ring } Z_2H_3(7) = Z_2\{e, 3, 10, 17\}\} \subseteq S$  be the subset subsemiring of  $S$ .

We have atleast 10 subset subsemirings for  $S$ .

Now having seen an example of a subset subsemiring we now proceed onto describe and define subset subsemiring.

**DEFINITION 3.2:** Let  $S = \{\text{Collection of all subsets of a loop ring } RL \text{ of a loop } L \text{ over a ring } R\}$  be the subset non associative semiring of the loop ring  $RL$ . Let  $P$  be a proper subset of  $S$ , if  $P$  under the operations of  $L$  is a subset semiring then we define  $P$  to be a subset subsemiring of  $S$ .

We will give some more examples of this concept.

**Example 3.4:** Let

$S = \{\text{Collection of all subsets of the loop ring } ZL_{15}(8)\}$  be the subset non associative semiring of the loop ring  $ZL_{15}(8)$ .

Let  $M_1 = \{\text{Collection of all subsets of the subloop ring } ZH_2(5) = Z\{e, 2, 7, 12\}\} \subseteq S$  be a subset subsemiring of  $S$ .

$$W = \{\{0\}, n\{e + g_1 + g_2 + \dots + g_{15}\} \text{ where } n \in Z^+\} \subseteq S.$$

$W$  is a subset subsemiring of  $S$ .

$P_1 = \{\text{Collection of all subsets of the subloop ring } ZH_1(3) = Z\{e, 1, 4, 7, 10, 13\}\} \subseteq S$  be the subset subsemiring of  $S$ .

**Example 3.5:** Let  $S = \{\text{Collection of all subsets of the loop ring } ZL_{17}(3) \text{ of the loop } L_{17}(3) \text{ over the ring } Z\}$  be the subset semiring of the loop ring.

$W = \{\{0\}, n\left(e + \sum_{i=1}^{17} g_i\right) \mid n \in Z^+\} \subseteq S$  is a subset subsemiring of  $S$ .

**Example 3.6:** Let  $S = \{\text{Collection of all subsets of the loop ring } Z_{18}L_{21}(11) \text{ of the loop } L_{21}(11) \text{ over the ring } Z_{18}\}$  be the subset semiring of the loop ring  $Z_{18}L_{21}(11)$ .

We see  $P_i = \{\text{Collection of all subsets of the subloop ring } Z_{18}H_i(7) \text{ of the subloop } H_i(7) \text{ over the ring } Z_{18}\}$  is the subset subsemiring of the loop subring  $Z_{18}H_i(7)$ ;  $1 \leq i \leq 7$ .

$M_j = \{\text{Collection of all subsets of the subloop subring } Z_{18}H_i(3)\}$  be the subset subsemiring of the loop subring  $Z_{18}H_i(3)$ ,  $1 \leq j \leq 3$ .

$W = \{\{0\}, n\left(e + \sum_{i=1}^{18} g_i\right) \mid n \in Z_{18}\} \subseteq S$  is also a subset subsemiring of  $S$ .

Thus S has atleast 11 subset subsemirings.

In view of these examples we have the following theorem.

**THEOREM 3.1:** *Let  $S = \{ \text{Collection of all subsets of the loop ring } ZL_n(m) \text{ of the loop } L_n(m) \text{ over the ring } Z \}$  be the subset semiring of the loop ring  $ZL_n(m)$ ,  $n = pqr$  where  $p, q$  and  $r$  are primes.  $S$  has atleast  $p + q + r + 1$  number of subset subsemirings.*

The proof is direct and hence left as an exercise to the reader.

However we say  $H_i(p)$ ,  $1 \leq i \leq p$ ,  $H_j(q)$ ,  $1 \leq j \leq q$  and  $H_k(r)$ ;  $1 \leq k \leq r$  give way to  $p + q + r$  subset subsemirings associated with these subloop ring.

Further  $W = \{ \{0\}, n \left( e + \sum_{i=1}^n g_i \right) \mid n \in Z^+ \} \subseteq S$  is also a subset subsemiring of S.

We see the subset semiring S has atleast  $p + q + r + 1$  number of subset subsemirings.

**Example 3.7:** Let  $S = \{ \text{Collection of all subsets of the loop ring } Z_9L_{105}(23) \text{ of the loop } L_{105}(23) \text{ over the ring } Z_9 \}$  be the subset semiring of the loop ring  $Z_9L_{105}(23)$ ,

$H_4(35) = \{e, 4, 39, 74\} \subseteq L_{105}(23)$  is a subloop of the loop  $L_{105}(23)$ .

$H_4(21) = \{e, 4, 25, 46, 67, 88\} \subseteq L_{105}(23)$  is a subloop of the loop  $L_{105}(23)$ .

$H_4(7) = \{e, 4, 11, 18, 25, 32, 39, 46, 53, 60, 67, 74, 81, 88, 95, 102\} \subseteq L_{105}(23)$  is a subloop of the loop  $L_{105}(23)$ .

$P_4 = \{ \text{Collection of all subsets the subloop ring } Z_9H_4(7) \} \subseteq S$  is a subset subsemiring of S.

$M_4 = \{\text{Collection of all subsets of the subloop ring } Z_9H_4(35)\} \subseteq S$  is a subset subsemiring of  $S$ .

$N_4 = \{\text{Collection of all subsets of the subloop ring } Z_9H_4(21)\} \subseteq S$  is a subset subsemiring of the subloop ring  $Z_9H_4(21)$ .

We see we have lots of subset subsemirings and has more than  $3 + 5 + 7 + 1 = 16$  subset subsemirings.

For  $P_4$ ,  $M_4$  and  $N_4$  are also subset subsemirings we have now  $21 + 35 = 56$  number of subset subsemirings.

**Example 3.8:** Let

$S = \{\text{Collection of all subsets of the loop ring } Z_5L_{45}(14)\}$  be the subset semiring of the loop ring  $Z_5L_{45}(14)$ .

The subloops of  $L_{45}(14)$  are as follows:

$H_1(3) = \{e, 1, 4, 7, 10, 13, 16, 19, 22, 25, 28, 31, 34, 37, 40, 43\}$  and we have  $H_2(3)$  and  $H_3(3)$  to be also subloops of  $L_{45}(14)$ .

$H_1(9) = \{e, 1, 10, 19, 28, 37\}$ ,  $H_2(9)$ ,  $H_3(9)$ , ...,  $H_9(9)$  are also subloops of  $L_{45}(14)$ .  $H_1(15) = \{e, 1, 16, 31\}$ ,  $H_2(15)$ , ...,  $H_{15}(15)$  are all subloops of  $L_{45}(14)$ .

This corresponds to each of the  $3 + 5 + 9 + 15 = 32$  subloops associated with each of them; we can have subset subsemirings of  $S$ .

Thus if we have many divisors of the integer  $n$  of the loop  $L_n(m)$  we have many subset subsemirings.

**Example 3.9:** Let  $S = \{\text{Collection of all subsets of the loop ring } Z_{11}L_{231}(20) \text{ of the loop } L_{231}(20) \text{ over the field } Z_{11}\}$  be the subset semiring of the loop ring  $Z_{11}L_{231}(20)$ .

We can have  $3 + 11 + 7 + 77 + 33 + 21 = 152$  number of subset subsemirings of  $S$ .



**Example 3.10:** Let

$S = \{\text{Collection of all subsets of the loop ring } Z_{13}L_{39}(8)\}$  be the subset semiring of the loop ring  $Z_{13}L_{39}(8)$ .

We have atleast  $13 + 3 = 16$  subset subsemirings.

Now having seen examples of subset subsemirings we proceed onto describe more properties about these subset semirings.

One of the specialities of loop rings are right quasi regular elements and left quasi regular elements. So we study how the subset loop semirings behave. We describe a subset semiring  $S$  of a loop ring  $RL$  to be Smarandache subset left (right) quasi regular if the loop ring  $RL$  has left (right) quasi regular elements.

We do not demand the whole of  $RL$  or  $S$  to be quasi regular.

We will illustrate this situation first by some examples.

Recall, we say if  $x, y \in RL$  (the loop ring of the loop  $L$  over  $R$ ) and  $y$  is the right quasi inverse of  $x$  then  $x + y - xy = 0$ . We just see then  $S$  the subset semiring of the loop ring  $RL$  has subset right (left) quasi regular elements.

**Example 3.11:** Let  $S = \{\text{Collection of all subsets of the loop ring } RL \text{ where } R \text{ is any commutative ring of characteristic zero and } L \text{ is the loop given by the following table;}$

*	e	a	b	c	d
e	e	a	b	c	d
a	a	e	c	d	b
b	b	d	a	e	c
c	c	b	d	a	e
d	d	c	e	b	a

be the subset semiring. Suppose  $R = Z$  is taken in the example.

Take  $A = \{e + b\} \in S$ ,  $B = \{(e + c)\} \in S$  to be the right subset quasi inverse of  $A$  in  $S$ ; for

$$\begin{aligned}
 A \circ B &= \{e + b\} \circ \{e + c\} \\
 &= \{(e + b) \circ (e + c)\} \\
 &= \{(e + b) + (e + c) - (e + b)(e + c)\} \\
 &= \{e + b + e + c - e - b - c - e\} \\
 &= \{0\} \in S.
 \end{aligned}$$

We see  $B = \{e + c\} \in S$  is the subset right quasi inverse of  $A = \{e + b\}$  in  $S$ . Take  $C = \{e + d\} \in S$ ;  $C$  is the subset left quasi inverse of  $A = \{e + b\} \in S$ . For consider

$$\begin{aligned}
 C \circ A &= \{e + d\} \circ \{e + b\} \\
 &= \{(e + d) \circ (e + b)\} \\
 &= \{e + d + e + b - e - d - b - e\} \\
 &= \{0\} \in S.
 \end{aligned}$$

We see  $C \neq B$  and these subsets in  $S$  are distinct.

Consider

$$\begin{aligned}
 B \circ A &= \{e + c\} \circ \{e + b\} \\
 &= \{(e + c) \circ (e + b)\} \\
 &= \{(e + c) + (e + b) - (e + c)(e + b)\} \\
 &= \{e + c + e + b - e - b - c - e\} \\
 &= \{0\}
 \end{aligned}$$

so  $B$  is the subset right quasi inverse of  $A = \{e + b\} \in S$ .

Clearly  $C = \{e + d\} \in S$  is the subset left quasi inverse of  $A = \{e + b\}$ . Note  $C \neq B$ .

Now consider  $B = \{e + c\}$  and  $A = \{e + b\} \in S$ .

$$\begin{aligned}
 B \circ A &= \{e + c\} \circ \{e + b\} \\
 &= \{(e + c) \circ (e + b)\} \\
 &= \{e + c + e + b - e - b - c - d\} \\
 &= \{e - d\} \neq \{0\}.
 \end{aligned}$$

$$\begin{aligned}
 A \circ C &= \{e + b\} \circ \{e + d\} \\
 &= \{(e + b) \circ (e + d)\} \\
 &= \{e + b + e + d - e - b - d - c\} \\
 &= \{e - c\} \neq \{0\}.
 \end{aligned}$$

So  $B \in S$  is not subset left quasi inverse of  $A = \{e + b\}$  and  $C = \{e + d\}$  is not a subset right quasi inverse of  $A = \{e + b\} \in S$ .

Thus the subset left quasi inverse and subset right quasi inverse of an element in  $S$  need not be the same.

Now another important feature which we wish to discuss and keep on record is that if  $S$  is any subset semiring of a loop ring and if  $A, B \in S$  then  $A \circ B$  or  $B \circ A$  in general need not be in  $S$ . That is  $S$  under the circle operation in general is not closed.

**Example 3.12:** Let  $S = \{\text{Collection of all subsets of the loop ring ZL of the loop L given in the following table};$

	*	e	a	b	c	d	}
e	e	a	b	c	d		
a	a	e	c	d	b		
b	b	d	a	e	c		
c	c	b	d	a	e		
d	d	c	e	b	a		

be the subset semiring of the loop ring ZL.

$$\begin{aligned}
 \text{Let } A &= \{e + a\} \in S \text{ we see} \\
 A \circ A &= \{e + a\} \circ \{e + a\} \\
 &= \{(e + a) \circ (e + a)\} \\
 &= \{e + a + e + a - (e + a) * (e + a)\} \\
 &= \{e + a + e + a - e - a - a - e\} \\
 &= \{0\} \in S.
 \end{aligned}$$

So  $A = \{e + a\} \in S$  is a subset quasi regular element of  $S$  as  $A = \{e + a\}$  is left and right subset quasi regular.

Consider  $B = \{a - d\}$  and  $C = \{e + a - c + d\} \in S$ ; we see

$$\begin{aligned}
 B \circ C &= \{a - d\} \circ \{e + a - c + d\} \\
 &= \{(a - d) \circ (e + a - c + d)\} \\
 &= \{a - d\} + (e + a - c + d) - (a - d) * \\
 &\quad (e + a - c + d)\} \\
 &= \{(a - d + e + a - c + d) - \\
 &\quad (a + e - d + b - d - c + b - a)\} \\
 &= \{a - d + e + a - c + d - a - e + d - b + d + \\
 &\quad c - b + a\} \\
 &= \{(2a - c + e) - (e - 2d + 2b - c)\} \\
 &= \{2a + 2d - 2b\} \neq \{0\}.
 \end{aligned}$$

Consider

$$\begin{aligned}
 C \circ B &= \{e + a - c + d\} \circ \{a - d\} \\
 &= \{(e + a - c + d) \circ (a - d)\} \\
 &= \{(e + a - c + d + a - d) - (e + a - c + d) * (a - d)\} \\
 &= \{(2a + e - c) - (a + e - b + c - d - b + e - a)\} \\
 &= \{(2a + e - c) - (c + 2e - 2b - d)\} \neq \{0\}.
 \end{aligned}$$

Now we will show  $M = \{a + b\} \in S$  has no subset right quasi inverse and no subset left quasi inverse in  $S$ .

Suppose  $P = \{a_0e + a_1a + a_2b + a_3c + a_4d \mid a_i \in Z; e, a, b, c, d \in L; 0 \leq i \leq 4\} \in S$  be the right quasi inverse of  $M = \{a + b\}$ ; then we get

$$\begin{aligned}
 M \circ P &= \{a + b\} \circ (a_0e + a_1a + a_2b + a_3c + a_4d) \\
 &= \{(a + b + a_0e + a_1a + a_2b + a_3c + a_4d) - \\
 &\quad (a + b) * (a_0e + a_1a + a_2b + a_3c + a_4d)\}
 \end{aligned}$$

$$\begin{aligned}
 &= \{(a + b + a_0e + a_1a + a_2b + a_3c + a_4d) - \\
 &\quad (a_0a + a_1e + a_2c + a_3d + a_4b + a_0b + a_1d \\
 &\quad + a_2a + a_3e + a_4c)\} \\
 &= \{a + b + (a_0 - a_1 - a_3) e + (a_1 - a_0 - a_2) a + \\
 &\quad (a_2 - a_4 - a_0) b + (a_3 - a_2 - a_4) c + (a_4 - a_3 - a_1)d\} \\
 &= \{0\}.
 \end{aligned}$$

Equating the like terms we get

$$\begin{aligned}
 a_0 - a_1 - a_3 &= 0 \\
 1 + a_1 - a_0 - a_2 &= 0 \\
 1 + a_2 - a_4 - a_0 &= 0 \\
 a_3 - a_2 - a_4 &= 0 \text{ and} \\
 a_4 - a_3 - a_1 &= 0.
 \end{aligned}$$

Solving the above equations we get  $a_0 = 3/5$ ,  $a_1 = -1/5$ ,  $a_2 = 1/5$ ,  $a_3 = 4/5$ ,  $a_4 = 3/5$ . Thus  $a_i \notin Z$  for  $i = 0, 1, 2, 3, 4$ . Thus  $P \notin S$ .

Hence  $M = \{a + b\}$  has no subset right quasi inverse.

Similarly we can show  $M = \{a + b\}$  has no subset quasi left inverse. So  $\{a + b\} = M$  does not belong to the quasi inverse elements in  $S$ . Thus  $S$  in general is not closed under the ‘o’ operation.

Now we will study the subset semiring of loop ring  $RL$  where  $R$  is of finite characteristic and  $L$  a loop.

**Example 3.13:** Let  $S = \{\text{Collection of all subsets of the loop ring } Z_2L \text{ where } L \text{ is the loop given by the following table;}$

*	e	a	b	c	d
e	e	a	b	c	d
a	a	e	c	d	b
b	b	d	a	e	c
c	c	b	d	a	e
d	d	c	e	b	a



$$\begin{aligned}
 &= \{(b + c) \circ (e + a + b + c + d)\} \\
 &= \{b + c + e + a + b + c + d + (b + c) * (e + a + b + c + d)\} \\
 &= \{a + d + e + e + a + b + c + d + e + b + c + d\} \\
 &= \{a + d + e\} \neq \{0\}.
 \end{aligned}$$

Take  $A = \{e + a + b + c + d\} \in S$ . Clearly  $A \circ A = \{0\}$  is the subset quasi inverse element in  $S$ .

**Example 3.14:** Let  $S = \{\text{Collection of all subsets of the loop ring } Z_2L_7(4) \text{ where the table of the loop } L_7(4) \text{ is as follows:}$

*	e	g <sub>1</sub>	g <sub>2</sub>	g <sub>3</sub>	g <sub>4</sub>	g <sub>5</sub>	g <sub>6</sub>	g <sub>7</sub>
e	e	g <sub>1</sub>	g <sub>2</sub>	g <sub>3</sub>	g <sub>4</sub>	g <sub>5</sub>	g <sub>6</sub>	g <sub>7</sub>
g <sub>1</sub>	g <sub>1</sub>	e	g <sub>5</sub>	g <sub>2</sub>	g <sub>6</sub>	g <sub>3</sub>	g <sub>7</sub>	g <sub>4</sub>
g <sub>2</sub>	g <sub>2</sub>	g <sub>5</sub>	e	g <sub>6</sub>	g <sub>3</sub>	g <sub>7</sub>	g <sub>4</sub>	g <sub>1</sub>
g <sub>3</sub>	g <sub>3</sub>	g <sub>2</sub>	g <sub>6</sub>	e	g <sub>7</sub>	g <sub>4</sub>	g <sub>1</sub>	g <sub>5</sub>
g <sub>4</sub>	g <sub>4</sub>	g <sub>6</sub>	g <sub>3</sub>	g <sub>7</sub>	e	g <sub>2</sub>	g <sub>5</sub>	g <sub>2</sub>
g <sub>5</sub>	g <sub>5</sub>	g <sub>3</sub>	g <sub>7</sub>	g <sub>4</sub>	g <sub>1</sub>	e	g <sub>2</sub>	g <sub>6</sub>
g <sub>6</sub>	g <sub>6</sub>	g <sub>7</sub>	g <sub>4</sub>	g <sub>1</sub>	g <sub>5</sub>	g <sub>2</sub>	e	g <sub>3</sub>
g <sub>7</sub>	g <sub>7</sub>	g <sub>4</sub>	g <sub>1</sub>	g <sub>5</sub>	g <sub>2</sub>	g <sub>6</sub>	g <sub>3</sub>	e

be the subset semiring of the loop ring  $Z_2L_7(4)$ .

Take  $A = \{e + g_1 + g_2 + \dots + g_7\} \in S$  is a subset quasi inverse element as  $A \circ A = \{0\}$ .

Take  $A_1 = \{e + g_1\} \in S$  we see

$$\begin{aligned}
 A_1 \circ A_1 &= \{e + g_1\} \circ \{e + g_1\} \\
 &= \{(e + g_1) \circ (e + g_1)\} \\
 &= \{e + g_1 + e + g_1 + (e + g_1) * (e + g_1)\} \\
 &= \{0 + e + g_1 + g_1 + e\} \\
 &= \{0\}.
 \end{aligned}$$

Thus  $A_1$  is a subset quasi inverse element of  $S$ .

We see  $A_i = \{e + g_i\}$ ,  $1 \leq i \leq 7$  are all subset quasi inverse elements of  $S$  as  $A_i \circ A_i = \{0\}$ ;  $1 \leq i \leq 7$ .

Consider  $A = \{e + g_1 + g_2 + g_3\}$  and  $B = \{g_4 + g_5\} \in S$ .

We find  $A \circ B$  and  $B \circ A$ .

Now

$$\begin{aligned}
 A \circ B &= \{e + g_1 + g_2 + g_3\} \circ \{g_4 + g_5\} \\
 &= \{(e + g_1 + g_2 + g_3) \circ (g_4 + g_5)\} \\
 &= \{(e + g_1 + g_2 + g_3 + g_4 + g_5) + (e + g_1 + g_2 + g_3) \\
 &\quad * (g_4 + g_5)\} \\
 &= \{((e + g_1 + g_2 + g_3 + g_4 + g_5 + g_4 + g_6 + g_3 + g_7 \\
 &\quad + g_5 + g_3 + g_7 + g_4)\} \\
 &= \{e + g_1 + g_2 + g_3 + g_4 + g_6\} \neq \{0\}.
 \end{aligned}$$

Since  $L_7(4)$  is a commutative loop so  $S$  is also a commutative subset semiring, we see  $A \circ B = B \circ A \neq \{0\}$ .

So they are neither subset quasi left inverse nor subset quasi right inverse of each other.

Suppose  $A = \{1 + g_1\}$  and  $B = \{1 + g_2\} \in S$ .

Now we know  $A \circ B = B \circ A$ .

Consider

$$\begin{aligned}
 A \circ B &= \{1 + g_1\} \circ \{1 + g_2\} \\
 &= \{(1 + g_1) \circ (1 + g_2)\} \\
 &= \{1 + g_1 + 1 + g_2 + (1 + g_1) * (1 + g_2)\} \\
 &= \{g_1 + g_2 + 1 + g_1 + g_2 + g_5\} \\
 &= \{1 + g_5\} \neq \{0\}.
 \end{aligned}$$

So  $A$  and  $B$  are not subset quasi inverses of each other.

In view of these results we have the following theorem.



**THEOREM 3.2:** Let  $S = \{\text{Collection of all subsets of the loop ring } Z_2L_n(m) \text{ where } L_n(m) \in L_n\}$  be the subset semiring.  $S$  has atleast  $(n+1)$  subset quasi inverse elements.

**Proof:** Follows from the fact  $\{(e + g_i)\} = A_i$  in  $S$  is such that  $A_i \circ A_i = \{0\}$ ;  $1 \leq i \leq n$  which runs to  $n$  distinct subset quasi inverse elements.

Take  $A = \{e + g_1 + \dots + g_n\} \in S$  is such that  $A \circ A = \{0\}$ . Hence the claim of the theorem.

**Example 3.15:** Let  $S = \{\text{collection of all subsets of the loop ring } Z_4L_5(2) \text{ of the loop } L_5(2) \text{ over the ring } Z_4\}$  be the subset semiring of the loop ring. Consider  $A_1 = \{2e + 2g_1\} \in S$ .

$$\begin{aligned} A_1 \circ A_1 &= \{2e + 2g_1\} \circ \{2e + 2g_1\} \\ &= \{(2e + 2g_1) \circ (2e + 2g_1)\} \\ &= \{2e + 2g_1 + 2e + 2g_1 - (2e + 2g_1)(2e + 2g_1)\} \\ &= \{0\}. \end{aligned}$$

$A_1$  is a subset quasi inverse element of  $S$ .

Take  $A_i = \{2e + 2g_i\}$  ( $1 \leq i \leq 5$ )  $\in S$ .

Clearly  $A_i$ 's are subset quasi inverse elements of  $S$  as  $A_i \circ A_i = \{0\}$ ,  $1 \leq i \leq 5$ .

Now  $A = \{2e + 2g_1 + 2g_2 + 2g_3 + 2g_4 + 2g_5\} \in S$  is such that  $A \circ A = \{0\}$  so that  $A$  is a subset quasi inverse element of  $S$  for  $A \circ A = \{0\}$ .

Consider  $\{(e + g_1)\} = B$  we see

$$\begin{aligned} B \circ B &= \{e + g_1\} \circ \{e + g_1\} \\ &= \{(e + g_1) \circ (e + g_1)\} \\ &= \{e + g_1 + g_1 + e\} \\ &= \{2(e + g_1)\} \\ &\neq \{0\}. \end{aligned}$$

Consider  $A = \{2e + 2g_1\}$  and  
 $B = \{e + g_1 + g_2 + g_3 + g_4 + g_5\} \in S$ .

Take

$$\begin{aligned} A \circ B &= \{2e + 2g_1\} \circ \{e + g_1 + g_2 + g_3 + g_4 + g_5\} \\ &= \{(2e + 2g_1) \circ (e + g_1 + g_2 + g_3 + g_4 + g_5)\} \\ &= \{(2e + 2g_1 + e + g_1 + g_2 + g_3 + g_4 + g_5) - \\ &\quad \{2e + 2g_1\} * (e + g_1 + g_2 + g_3 + g_4 + g_5)\} \\ &= \{3e + 3g_1 + g_2 + g_3 + g_4 + g_5 - \{2e + 2g_1 + \\ &\quad 2g_2 + 2g_3 + 2g_4 + 2g_5 + 2g_1 + 2e + 2g_3 + \\ &\quad 2g_5 + 2g_2 + 2g_4\} \\ &= \{3e + 3g_1 + g_2 + g_3 + g_4 + g_5\} \neq \{0\}. \end{aligned}$$

We will give some more examples of them.

**Example 3.16:** Let  $S = \{\text{Collection of all subsets of the loop ring } Z_6L_9(5) \text{ of the loop } L_9(5) \text{ over the ring } Z_6\}$  be the subset semiring of the loop ring  $Z_6L_9(5)$ .

We see  $A = \{e + g_1 + g_2 + g_3 + g_4 + g_5 + \dots + g_9\} \in S$  is such that  $A \circ A = \{0\}$  that is  $A$  is the subset quasi inverse element of  $S$ .

Take  $B = \{3e + 3g_1 + 3g_2 + \dots + 3g_9\} \in S$  is such that  $B \circ B = \{0\} \in S$ .

We see  $S$  has some subset quasi inverse elements.

**Example 3.17:** Let  $S = \{\text{Collection of all subsets of the loop ring } Z_{10}L_9(5) \text{ of the loop } L_9(5) \text{ over the ring } Z_{10}\}$  be the subset semiring of the loop ring  $Z_9L_9(5)$ .

We see  $S$  contains subset quasi inverse elements.

Take  $A = \{e + g_1 + \dots + g_9\} \in S$ ,  $A \circ A = \{0\}$  so  $A$  is the quasi inverse subset of  $S$ .

Now  $\{e + g_1\} = B$  in  $S$  is such that

$$\begin{aligned} B \circ B &= \{e + g_1\} \circ \{e + g_1\} \\ &= \{(e + g_1) \circ (e + g_1)\} \\ &= \{e + g_1 + g_1 + e\} \\ &= \{2g_1 + 2e_1\} \\ &\neq \{0\}. \end{aligned}$$

Thus we can have subsets semirings which has subset

$$A = \{5e + 5g_1\} \text{ and } B = \{5e + 5g_1 + \dots + 5g_9\} \in S.$$

$$\begin{aligned} A \circ B &= \{5e + 5g_1\} \circ \{5e + 5g_1 + \dots + 5g_9\} \\ &= \{(5e + 5g_1) \circ (5e + 5g_1 + \dots + 5g_9)\} \\ &= \{5e + 5g_1 + 5e + 5g_1 + 5g_2 + \dots + 5g_9 + \\ &\quad (5e + 5g_1 + \dots + 5g_9) * (5e + 5g_1 + \dots + 5g_9)\} \\ &= \{5g_2 + \dots + 5g_2\} \\ &\neq \{0\}. \end{aligned}$$

So  $A$  and  $B$  are not subset quasi regular elements of each other.

**Example 3.18:** Let  $S = \{\text{Collection of all subsets of the loop ring } Z_{19}L_5(2) \text{ of the loop } L_5(2) \text{ over the field } Z_{19}\}$  be the subset semiring.

Find all the subset quasi regular elements of  $S$ .

Now we just define and describe the notion of augmentation ideal of a subset semiring  $S$  a loop ring  $RL$ .

**DEFINITION 3.3:** Let  $S$  be a subset semiring of a loop ring  $RL$ .

If  $W(S) = \{A \in S \mid A = \{\alpha_1 \dots \alpha_n\} \text{ and } \alpha_i = \sum \beta_i g_i \in RL \text{ with } \sum \beta_i = 0, 1 \leq i \leq n\}$ , then  $W(S)$  is defined as the augmentation subset semiring ideal of the subset loop semiring  $S$ .

We will first give some examples of this new concept before we discuss about the properties of  $W(S)$ .

**Example 3.19:** Let  $S = \{\text{Collection of all subsets of the loop ring } Z_4L_5(2) \text{ of the loop } L_5(2) \text{ over the ring } Z_4\}$  be the subset semiring of the loop ring.

Take  $A = \{2e + g_1 + g_3, g_1 + g_2 + g_3 + g_4, g_1 + g_2 + 2g_3, 2g_1 + g_3 + g_5\} \in S$ . We see  $A$  is such that sum of the support of each element of  $A$  is zero.

For if  $A = \{\alpha_1 = 2e + g_1 + g_3, \alpha_2 = g_1 + g_2 + g_3 + g_4, \alpha_3 = g_1 + g_2 + 2g_3 \text{ and } \alpha_4 = 2g_1 + g_3 + g_5\} \in S$ .

We see  $2 + 1 + 1 = 0$  for  $\alpha_1 \in A$

for  $\alpha_2; 1 + 1 + 1 + 1 \equiv 0 \pmod{4}$

for  $\alpha_3; 1 + 1 + 2 \equiv 0 \pmod{4}$  and

for  $\alpha_4; 2 + 1 + 1 \equiv 0 \pmod{4}$ .

So  $A \in W(S)$  and  $W(S) \neq \{0\}$ . Take  $B = \{3g_1, 2g_2\}$ . Clearly  $B \notin W(S)$ .

Take  $C = \{2g_1 + 2e, 2g_1 + 2g_2 + 2g_3 + 2e, 2g_1 + 2g_4, 2g_5 + 2e\} \in S$ .

Clearly  $C \in W(S)$ .

Thus we see  $S$  has elements  $A$  which are in  $W(S)$  and some of them are not in  $W(S)$ .

We have a collection of elements in  $S$  which are not in  $W(S)$ .

**Example 3.20:** Let  $S = \{\text{Collection of all subsets of the loop semiring } (Z^+ \cup \{0\})L_{21}(11) \text{ of the loop } L_{21}(11) \text{ over the semiring } Z^+ \cup \{0\}\}$  be the subset semiring of the loop semiring  $(Z^+ \cup \{0\})L_{21}(11)$ . Clearly  $W(S) = \{0\}$ .

**Example 3.21:** Let  $S = \{\text{Collection of all subsets of the loop lattice } LL_{23}(7), L_{23}(7) \text{ is a loop in } L_{23} \text{ where } L \text{ is the lattice}$

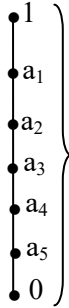

be the subset semiring of the loop lattice  $LL_{23}(7)$ .

Clearly  $W(S) = \{0\}$ .

**Example 3.22:** Let  $S = \{\text{Collection of all subsets of the loop semiring } LL_{29}(7)\}$  be the subset semiring of the loop semiring  $LL_{29}(7)$  where  $L$  is the lattice given by

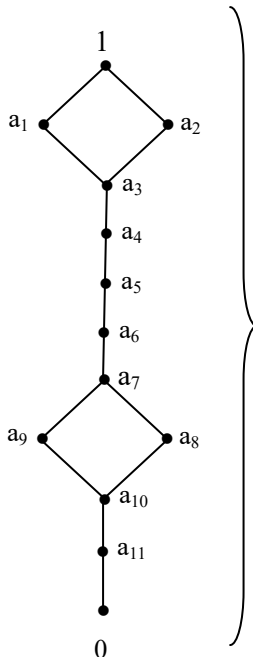

be the subset semiring .We see  $W(S) = \{0\}$ .

**Example 3.23:** Let

$S = \{\text{Collection of all subsets of the loop ring } Z_5(g)L_{23}(8)\}$  be the subset semiring of the loop ring.  $S$  has  $W(S) \neq \{0\}$ . For let  $A \in S$  if every element in  $A$  is such that sum of the coefficients of its elements is zero we see  $A \in W(S)$ .

$A_1 = \{e + g_1 + g_2 + g_3 + g_4\} \in W(S)$ ,  $A_2 = \{2a_1 + 3e, 4e + a_2\} \in W(S)$  and so on.

**Example 3.24:** Let

$S = \{\text{Collection of all subsets of the loop ring } ZL_{21}(5)\}$  be the subset semiring of the loop ring  $ZL_{21}(5)$ . Clearly  $W(S) \neq \{0\}$ . For take

$A = \{8e - 2g_1 - 6g_2, -7e + 3g_1 - 4g_2, 6e + g_1 - 4g_2 - g_3 - 2g_4\} \in S$ . We see  $A \in W(S)$ .

Thus  $W(S) \neq \{0\}$ .

**Example 3.25:** Let

$S = \{\text{Collection of all subsets of the loop ring } RL_m(n)\}$  be the subset semiring of the loop ring  $RL_m(n)$ .

Clearly  $W(S) \neq \{0\}$ .

**Example 3.26:** Let

$S = \{\text{Collection of all subsets of the loop ring } QL_{29}(7)\}$  be the subset semiring of the loop ring  $QL_{29}(7)$ .

$W(S) \neq \{0\}$ .

**Example 3.27:** Let  $S = \{\text{Collection of all subsets of the loop ring } Z(g)L_9(8) \text{ with } g^2 = 0\}$  be the subset semiring of the loop ring  $Z(g)L_9(8)$ .  $W(S) \neq \{0\}$ .

Take  $A = \{5ge - 5g_1, 8g_1 - 2g_2 - 4g_3 - g_4 - g_5\} \in S$  is such that  $A \in W(S)$ .

$B = \{4g_1 + 6g_2 - 3g_3 - 7g_4, 9g_1 - 8g_4 - g_2\} \in S$  is such that  $B \in W(S)$ . Thus  $W(S) \neq \{0\}$ .

In view of all these we have the following theorems.

**THEOREM 3.3:** *Let  $S = \{Collection\ of\ all\ subsets\ of\ the\ loop\ ring\ RL\ where\ R\ is\ a\ ring\ of\ characteristic\ zero\ or\ p\ and\ L\ any\ loop\}$  be the subset semiring of the loop ring  $RL$ ,  $W(S) \neq \{0\}$ .*

Proof is direct and hence left as an exercise to the reader.

**THEOREM 3.4:** *Let  $S = \{Collection\ of\ all\ subsets\ of\ the\ loop\ semiring\ PL_n(m); L_n(m) \in L_n; P\ a\ semiring\ R^+ \cup \{0\}\ or\ Q^+ \cup \{0\}\ or\ Z^+ \cup \{0\}\ or\ a\ lattice\}$  be the subset semiring of the loop semiring  $PL_n(m)$ . Then  $W(S) = \{0\}$ .*

Proof is direct as in  $P$  we cannot have  $a + b = 0$  ( $a \neq 0$  and  $b \neq 0, a, b \in P$ ).

Now we can give examples of these situations.

**Example 3.28:** Let  $S = \{Collection\ of\ all\ subsets\ of\ the\ group\ ring\ Z_2L_5(2)\}$  be the subset semiring of the loop ring.

$W(S) \neq \{0\}$ , infact  $W(S) = \{\{e + g_1\}, \{e + g_2\} \dots \{e + g_5\}, \{g_1 + g_2\}, \{g_1 + g_3\}, \dots, \{g_1 + g_5\}, \dots, \{g_4 + g_5\} \{e + g_1 + g_2 + g_3\} \{e + g_1 + g_2 + g_4\}, \dots, \{g_1 + g_2 + g_3 + g_4\}, \{0\}$  and all subsets got from these}.

That is  $A \in W(S)$  if and only if  $|\text{supp } \alpha| = 2$  or  $4$  or even for every element  $\alpha$  in  $A$ .

**Example 3.29:** Let  $S = \{Collection\ of\ all\ subsets\ of\ the\ loop\ ring\ Z_{16}L_{15}(8)\}$  be the subset semiring of the loop ring  $Z_{16}L_{15}(8)$ .

$W(S) \neq \{0\}$ .

Further if  $A \in W(S)$  then every element  $\alpha$  in  $A$  is such that sum of the coefficients of  $\alpha$  is 16.

For if  $\{\alpha = 4e + 8g_1 + 4g_2 + 8g_3 + 8g_2 + 12g_1 + 4g_4\} = A$  then  $A \in W(S)$ . Thus  $W(S) \neq \{0\}$ .

**Example 3.30:** Let  $S = \{\text{Collection of all subsets of the loop ring } Q(g_1, g_2)L_{17}(4)\}$  be the subset semiring of the loop ring. ( $g_1^2 = g_2^2 = g_1g_2 = g_2g_1 = 0$ ).

$W(S) \neq \{0\}$ . Infact  $o(W(S)) = \infty$ .

**Example 3.31:** Let  $S = \{\text{Collection of all subsets of the loop semiring } LL_9(8)\}$  where

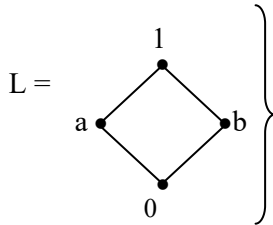

be the subset semiring of  $S$ .

We see  $W(S) = \{0\}$ . If  $L$  is replaced by  $R^+ \cup \{0\}$  or  $Q^+ \cup \{0\}$  or  $Z^+ \cup \{0\}$  or by any chain lattice still  $W(S) = \{0\}$ .

Next we study about the subset idempotents in subset non associative semiring of a loop ring.

We say  $A \in S$  is a subset idempotent if  $A * A = A$ .  $A \neq \{0\}$  or  $A \neq \{e\}$ .

We will first give examples of them.



**Example 3.32:** Let

$S = \{\text{Collection of all subsets of the loop ring } \text{RL}_{21}(11)\}$  be the subset semiring of the loop ring.

Take  $A = \left\{ \frac{1}{2} \{e + g_1\} \right\} \in S$  we see

$$\begin{aligned} A * A &= \left\{ \frac{1}{2} \{e + g_1\} \right\} * \left\{ \frac{1}{2} \{e + g_1\} \right\} \\ &= \left\{ \frac{1}{4} \{e + 2g_1 + g_1^2\} \right\} \\ &= \left\{ \frac{1}{4} \{e + 2g_1 + e\} \right\} \\ &= \left\{ \frac{1}{2} \{e + g_1\} \right\} = A. \end{aligned}$$

Thus  $A \in S$  is a subset idempotent of  $S$ . In fact  $S$  has atleast 21 subset idempotents.

$A_i = \left\{ \frac{1}{2} \{e + g_i\} \right\} \in S; 1 \leq i \leq 21$  are all subset idempotents of  $S$ .

Finally  $M = \left\{ \frac{1}{22} \{e + g_1 + \dots + g_{21}\} \right\} \in S$  is such that  $M * M = M$ .

Thus  $M$  is also a subset idempotent of  $S$ .

**Example 3.33:** Let  $S = \{\text{Collection of all subsets of the loop semiring } (Q^+ \cup \{0\})L_{19}(8)\}$  be the subset semiring of the loop ring  $(Q^+ \cup \{0\})L_{19}(8)$ .

$S$  has 20 non trivial subset idempotents given by

$$A_i = \left\{ \frac{1}{2} \{e + g_i\} \right\}, 1 \leq i \leq 19 \in S \text{ are such that } A_i * A_i = A_i.$$

Further  $M = \left\{ \frac{1}{20} \{e + g_1 + \dots + g_{19}\} \right\} \in S$  is such that  $M * M = M$ .

Thus  $S$  has atleast 20 non trivial subset idempotents.

**Example 3.34:** Let  $S = \{ \text{Collection of all subsets of the loop semiring } (Z^+ \cup \{0\})L_{23}(3) \}$  be the subset semiring of the loop semiring  $(Z^+ \cup \{0\})L_{23}(3)$ .

We see  $S$  has no nontrivial subset idempotents for  $A = \{0\} \in S$  is such that  $A * A = \{0\} = A$  and  $B = \{e\} \in S$  is such that  $B * B = \{e\} = B$ .

Apart from this the subset semiring of the loop ring has no subset idempotents.

**Example 3.35:** Let  $S = \{ \text{Collection of all subsets of the loop lattice } LL_{25}(8) \}$  be the subset semiring of the loop lattice  $LL_{25}(8)$  where  $L =$

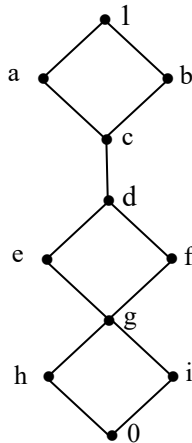

S has only subset idempotents of the form  $\{0\} = A_1, A_2 = \{e\}$  and  $\{ae\} = A_3, A_4 = \{be\}, A_5 = \{ce\}, \dots, A_{11} = \{ie\}$ .

Apart from this S has no nontrivial subset idempotents.

**Example 3.36:** Let

$S = \{\text{Collection of all subsets of the loop lattice } LL_{23}(7)\}$  be the subset semiring of the loop lattice  $LL_{23}(7)$  where  $L =$

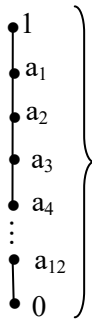

$A_i = \{a_i, e\} \in S$  are subset idempotents of S;  $1 \leq i \leq 12$ .

Apart from this  $A = \{0\}$  and  $B = \{e\}$  are also subset idempotents of S.

These are the only subset idempotents of S. S does not contain any other subset idempotents.

**Example 3.37:** Let

$S = \{\text{Collection of all subsets of the loop ring } Z_{12}L_5(2)\}$  be the subset semiring of the loop ring  $Z_{12}L_5(2)$ .

$$\{4e + 4g\} = A \in S.$$

$$\begin{aligned} \text{We see } A * A &= \{4e + 4g\} * \{4e + 4g\} \\ &= \{4e + 4e + 8g\} \\ &= \{8e + 8g\} \neq A. \end{aligned}$$

We see  $\{4e\} = A_i \in S$  are such that  $A_i * A_i = A_i$ .

**Example 3.38:** Let

$S = \{\text{Collection of all subsets of the loop ring } Z_6L_7(2)\}$  be the subset semiring of the loop ring  $Z_6L_7(2)$ .  $S$  has subset idempotents.

$$A = \{3e + 3g_1\} \in S.$$

$A * A = \{3e + 3\} \in S$  is not a subset idempotent in  $S$ .

$$A_2 = \{3e + 3g_2\} \in S \text{ is such that } A_2 * A_2 \neq A_2 = \{0\}.$$

Further  $B = \{3e + 3g_1 + 3g_2 + 3g_3 + 3g_4 + 3g_5 + 3g_6 + 3g_7\} \in S$  is such that  $B * B \neq B$  is not a subset idempotent of  $S$ .

**Example 3.39:** Let

$S = \{\text{Collection of all subsets of the loop ring } Z_{10}L_{11}(7)\}$  be the subset semiring of the loop ring  $Z_{10}L_{11}(7)$ .

$S$  has non trivial subset idempotents;  $A = \{5e + 5g_1\} \in S$  is such that

$$\begin{aligned} A * A &= \{5e + 5g_1\} * \{5e + 5g_1\} \\ &= \{5e + 5g_1\} = A \in S. \end{aligned}$$

So  $A$  is a subset idempotent of  $S$ .

$B = \{5e + 5g_1 + \dots + 5g_{11}\} \in S$  is such that  $B * B = B \in S$  is a subset idempotent of  $S$ .

**Example 3.40:** Let

$S = \{\text{Collection of all subsets of the loop ring } Z_{14}L_5(2)\}$  be the subset semiring of the loop ring  $A = \{7e + 7g_1\} \in S$  is such that  $A * A = A$  is a subset idempotent.

$$B = \{7e + 7g_1 + \dots + 7g_5\} \in S \text{ is such that } B * B = B.$$

Thus  $B$  is a subset idempotent.

In view of all these we have the following theorem which guarantees non trivial subset idempotents in  $S$ .

**THEOREM 3.5:** *Let  $S = \{\text{Collection of all subsets of the loop ring } Z_{2p}L_n(m) \text{ where } p \text{ is an odd prime}\}$  be the subset non associative semiring of the loop ring  $Z_{2p}L_n(m)$ , then  $S$  has atleast  $(n+2)$  subset idempotents.*

**Proof:** Follows from the simple fact if  $A_i = \{pe + pg_i\} \in S$  then  $A_i * A_i = A_i$  is not a subset idempotent for  $i = 1, 2, \dots, n$  which accounts for  $n$  subsets which are subset idempotents in  $S$ .

Now  $B = \{pe + pg_1 + \dots + pg_n\} \in S$  is such that  $B * B \neq B$  so  $B$  is a subset idempotent of  $S$ .

Further  $T = \{pe\}$  in  $S$  is such that  $T * T = T$  is a subset idempotent of  $S$  which accounts for atleast  $n + 2$  non trivial subset idempotents in  $S$ .  $P = \{e\} \in S$  is a trivial subset idempotent of  $S$ .

**Example 3.41:** Let

$S = \{\text{Collection of all subsets of the loop ring } Z_{15}L_7(3)\}$  be the subset semiring. Now  $\{(6e + 6g)\} = A \in S$  is a subset idempotent of  $A$  though  $6 \in Z_{15}$  is such that  $6^2 \equiv 36 \equiv 6 \pmod{15}$ . So  $A_1 = \{6e\} \in S$  is a subset idempotent.

**Example 3.42:** Let

$S = \{\text{Collection of all subsets of the loop ring } Z_{30}L_9(8)\}$  be the subset semiring of the loop ring  $Z_{30}L_9(8)$ .

Take  $\{(6e + 6g)\} = A \in S$ , we see

$$\begin{aligned} A^2 &= A * A \\ &= \{(6e + 6g) * (6e + 6g)\} \\ &= \{6e + 6e + 12g\} \\ &= \{12e + 12g\}. \end{aligned}$$

$$\begin{aligned} B &= (10g + 10e) \in S, \\ B * B &= \{10e + 10 + 20g\} \\ &= \{20e + 20g\} = T \end{aligned}$$

$$\begin{aligned}
 T * T &= \{400e + 400e + 400g + 400g\} \\
 &= \{10e + 10e + 10g + 10g\} \\
 &= \{20e + 20g\} \\
 &= T \in S.
 \end{aligned}$$

In view of all these we define a semipseudo subset idempotent in S.

Let  $A \in S$  if  $A * A \neq A$  thus  $A * A = B$  then  $B * B = B$  then we define A to be a semipseudo subset idempotent of S.

**Example 3.43:** Let  $S = \{\text{Collection of all subsets of the loop ring } Z_{30}L_{29}(7)\}$  be the subset semiring of the loop ring  $Z_{30}L_{29}(7)$ .

$$\begin{aligned}
 \text{Let } A &= \{10e + 10g\} \in S \\
 A * A &= \{10e + 10g\} * \{10e + 10g\} \\
 &= \{10e + 10e + 10g + 10g\} \\
 &= \{20e + 20g\} \in S.
 \end{aligned}$$

$$\text{Let } A * A = T, T * T = T.$$

So A is a semipseudo subset idempotent of S.

We will give one or two examples of semi pseudo subset idempotents before we proceed onto describe those subset semirings which contain subset idempotents.

**Example 3.44:** Let  $S = \{\text{Collection of all subsets of the loop ring } Z_{10}L_9(8)\}$  be the subset semiring of the loop ring  $Z_{10}L_9(8) \{(5e + 5g_2)\} = A \in S$ .

$$\begin{aligned}
 A * A &= \{5e + 5g_2\} * \{5e + 5g_2\} \\
 &= \{25e + 25e + 50g_2\} \\
 &= \{0\}.
 \end{aligned}$$

Thus S has atleast 9 subset nilpotents of order two.

Let  $B = \{2e + 2g_1\} \in S$

$$\begin{aligned} B * B &= \{2e + 2g_1\} * \{2e + 2g_1\} \\ &= \{4e + 4e + 8g_1\} \\ &= \{8e + 8g_1\} \\ &= T \end{aligned}$$

Now  $T * T = T$ . Thus  $B$  is a semipseudo subset idempotent of  $S$ .

Infact we have atleast nine semipseudo subset idempotents in  $S$ .

We see  $C = \{4e + 4g_1\} \in S$  is not a semipseudo subset idempotent of  $S$ .

**Example 3.45:** Let

$S = \{\text{Collection of all subsets of the loop ring } Z_{22}L_5(3)\}$  be the subset semiring of the loop ring  $Z_{22}L_5(3)$ .

Now we for  $A = \{11e + 11g_2\} \in S$

$$\begin{aligned} A * A &= \{121e + 121e + 2 \times 121g_2\} \\ &= \{22e + 22g\} \\ &= \{0\}. \end{aligned}$$

So we have atleast 5 subset nilpotent elements of order two.

Take  $B = \{2e + 2g_2\} \in S$ .

$$\begin{aligned} B * B &= \{2e + 2g_2\} * \{2e + 2g_2\} \\ &= \{4e + 4g_2 + 4g_2 + 4e\} \\ &= \{8e + 8g_2\} \in S. \end{aligned}$$

$B$  is not a semi pseudo subset idempotent of  $S$ .

$C = \{4e + 4g_1\} \in S$  is also not a pseudo subset semiidempotent of  $S$ .

We see a subset semiring of a loop ring  $Z_{2p}L_n(m)$  has always subset zero divisors only under certain conditions it has subset semipseudo idempotents and subset idempotents.

In view of all these we give the following theorem.

**THEOREM 3.6:** *Let*

$S = \{ \text{Collection of all subsets of the loop ring } Z_pL \}$  *be the subset semiring of the loop ring }  $Z_pL$ .*

$A = \{ ag_i + bg_j \} \in S$  *is a subset idempotent of }  $Z_pL$  if and only if }  $g_i = e, g_j^2 = e$  with }  $a = (p+1)/2$  and }  $b = (p-1)/2$ .*

Proof is direct and hence is left as an exercise to the reader.

**Corollary 3.1:** *If }  $Z_p$  is replaced by }  $Z$  in the above the theorem then }  $S$  has no subset idempotent.*

**THEOREM 3.7:** *Let }  $S = \{ \text{Collection of all subsets of the loop ring } Z_pL \text{ where } L = \{ h_1 = e, h_2, \dots, h_n \}, p \text{ a prime} \}$  be the subset semiring of the loop ring }  $Z_pL$ .*

*An element of the form }  $A = \{ x = m ( e + h_2 + \dots + h_n ) \} \in S$  ( }  $m \neq 0$ ) is a subset idempotent if and only if }  $mn = 1 \pmod{p}$ .*

**Proof:** Let }  $A = \{ m ( e + h_2 + \dots + h_n ) \} \in S$  be a subset idempotent of }  $S$ . For }  $A * A = A$  as }  $m^2n \equiv m \pmod{p}$  that is }  $mn \equiv 1 \pmod{p}$  as }  $0 \neq m \in Z_p$ .

Conversely if }  $mn = 1 \pmod{p}$  then }  $m^2n \equiv m \pmod{p}$  so }  $A * A = A$ . Thus }  $A$  is a subset idempotent of }  $S$ .

**THEOREM 3.8:** *Let }  $S = \{ \text{Collection of all subsets of the loop ring } Z_2L, \text{ where } L = \{ h_1 = e, h_2, \dots, h_n \} \text{ be a finite loop } h_i^2 = e, i = 1, 2, \dots, n \}$  be the subset semiring of the loop ring }  $Z_2L$ .*

*}  $A \in S$  is a subset idempotent then the following holds:*



(1)  $A = \{x\} \in S, x \in Z_2L$  is a subset idempotent then  $|Supp x|$  is even and  $e \in |Supp x|$ .

(2)  $|Supp x|$  is odd number and  $e \in |Supp x|$ .

If the subset semiring is commutative then S has only trivial subset idempotents.

We will illustrate these situations by an example or two.

**Example 3.46:** Let

$S = \{\text{Collection of all subsets of the loop ring } Z_2L_{21}(11)\}$  be the subset semiring of the loop ring  $Z_2L_{21}(11)$ .  $W(S) \neq \{0\}$ .

**Example 3.47:** Let

$S = \{\text{Collection of all subset of the loop ring } Z_2L_7(4)\}$  be the subset semiring of the loop ring  $Z_2L_7(4)$ .

$$A_i = \{g_i + e\} \in S; A_i * A_i = \{0\} \text{ for } i = 1, 2, \dots, 7.$$

$$B = \{e + g_1 + g_2 + \dots + g_7\} \in S \text{ such that } B * B = \{0\}$$

Interested reader can find subset idempotents in subset semiring.

We can now proceed onto describe Smarandache subset idempotent and Smarandache subset pseudo zero divisor.

We recall a subset semiring S to have Smarandache subset idempotents in S.

Let  $A \in S \setminus \{0\}$ , A is called a Smarandache subset idempotent (S-subset idempotent) of S if  $A * A = A$ .

There exist a  $B \in S \setminus \{A\}$  such that

- (i)  $B * B = A$ .
- (ii)  $A * B = B$  or  $B * A = B$  or used in mutually exclusive sense.

**Example 3.48:** Let

$S = \{\text{Collection of all subsets of the loop ring } Z_5L_5(3)\}$  be the subset semiring of the loop ring  $Z_5L_5(3)$ .

$$\begin{aligned} A &= \{1 + g_1 + \dots + g_5\} \in S \\ A * A &= A. \quad B = \{3 + 3g_1\} \in S. \\ B * B &= B; B * A = A. \end{aligned}$$

Take  $X = 4 + 4g_1 + 4g_2 + 4g_3 + 4g_4 + 4g_5 \in S$ ;

$$\begin{aligned} X * X &= A. \quad \text{Take } Y = 2 + 2g_1 \\ Y * Y &= B; B * Y = Y. \end{aligned}$$

Thus  $A$  is a Smarandache subset idempotent of  $S$ .

In view of this we have the following theorem.

**THEOREM 3.9:** Let

$S = \{\text{Collection of all subsets of the loop ring } Z_pL_n(m) \ (n = p)\}$  be the subset semiring.

Then  $A = \{1 + g_1 + \dots + g_p\}$  and

$B = \left\{ \frac{p+1}{2} + \left( \frac{p+1}{2} \right) g_i \right\} \in S$  are the  $S$ -subset idempotents of  $S$ .

Proof is obvious and hence left as an exercise to a reader.

Just we recall the notion of Smarandache subset zero divisor of the subset semiring.

Let  $S$  be a subset semiring which is non associative.

An element  $A \in S \setminus \{0\}$  is said to be a Smarandache subset zero divisor ( $S$ -subset zero divisor) if  $A * B = \{0\}$  for some  $B \neq \{0\}$  in  $S$  and there exist  $X, Y \in S \setminus \{0, A, B\}$ ;  $X \neq Y$  such that

- (i)  $A * X = \{0\}$  or  $X * A = \{0\}$
- (ii)  $B * Y = \{0\}$  or  $Y * B = \{0\}$
- (iii)  $X * Y = \{0\}$  or  $Y * X = \{0\}$ .

We define Smarandache subset pseudo zero divisor (S-subset pseudo zero divisor).

Let S be a subset semiring.

Let  $X \in S \setminus \{0\}$  is a zero divisor in S if there exist a  $Y \in S \setminus \{0\}$  with  $X * Y = \{0\}$ .

We say X is a Smarandache subset pseudo zero divisor (S-subset pseudo zero divisor) if there exist

$$A \in S \setminus \{X, Y, \{0\}\} \text{ with } A * Y = \{0\} \text{ or}$$

$$A * X = \{0\}. A * A = \{0\}.$$

We now proceed onto give examples of them.

**Example 3.49:** Let

$S = \{\text{Collection of all subsets of the loop ring } Z_2L_5(3)\}$  be the subset semiring of the loop ring  $Z_2L_5(3)$ .

Let  $X = \{1 + g_1\} \in S$ ,  $Y = \{1 + g_1 + g_2 + g_3 + g_4 + g_5\} \in S$  is such that  $X * Y = \{0\}$  and  $A = \{1 + g_2\}$  is such that  $A * Y = \{0\}$  with  $A * A = \{0\}$  so X is a S-subset pseudo zero divisor and not a S-subset zero divisor.

We have the following theorem.

**THEOREM 3.10:** *Let  $S = \{\text{Collection of all subsets of the loop ring } Z_{2p}L_n(m); p \text{ an odd prime}\}$  be the subset semiring of the loop ring  $Z_{2p}L_n(m)$ .  $X = \{p + pg_i\} \in S$  is a Smarandache subset pseudo zero divisor for all  $\{g_i\} \in S (g_i \in L_n(m))$ .*

The proof is direct and hence left as an exercise to the reader.

**Example 3.50:** Let

$S = \{\text{Collection of all subsets of the loop ring } Z_{14}L_{11}(3)\}$  be the subset semiring of the loop ring  $Z_{14}L_{11}(3)$ .

Take  $\{7e + 7g_i\} = A_i \in S$  and  $B = \{e + g_1 + g_2 + \dots + g_{11}\} \in S$ .

$$A_i * B = \{0\}, A_i * A_i = \{0\} \text{ for } i = 1, 2, \dots, 11.$$

In view of all this we see for  $S = \{\text{Collection of all subsets of the loop ring } Z_{2p}L_n(m); p \text{ is an odd prime}\}$  be the subset semiring of the loop ring  $Z_{2p}L_n(m)$ .

We see  $A_i = \{pe + pg_i\} \in S$  is a such that  $A_i * A_i = \{0\}; i = 1, 2, \dots, n$ .

We define the notion of Smarandache weak subset divisors of zero of a subset semiring  $S$ .

Let  $S = \{\text{Collection of all subsets of the loop ring } RL\}$  be the subset semiring of the loop ring  $RL$ .  $X \in S \setminus \{0\}$  is a Smarandache subset weak zero divisor ( $S$ -subset weak zero divisor) if there exists  $Y \in S \setminus \{0\}, X$  such that

$$\begin{aligned} X * Y &= \{0\} \text{ satisfies the following conditions;} \\ A * X &= \{0\} \text{ or } X * A = \{0\} \\ B * Y &= \{0\} \text{ or } Y * B = \{0\} \\ X * Y &= \{0\} \text{ or } Y * Y = \{0\}. \end{aligned}$$

We give some examples of them.

**Example 3.51:** Let  $K$  be a field and  $L$  a disassociative finite loop or a power associative finite loop.

$S = \{\text{Collection of all subsets of the loop ring } KL\}$  be the subset semiring.  $S$  has Smarandache subset weak divisors of zero.

$$\text{For } \{g\} = A \in S \text{ is such that } \{g\}^n = A^n = \{1\} (g \in L).$$

Let  $B = (1 + g + \dots + g^{n-1}) \in S$  where  $B$  is the subset in  $S$  and  $\{g, g^2, \dots, g^{n-1}, g^n=1\}$  is a subgroup of  $L$ .

We see  $X = \{1 - g\}$  and  $Y = \{1 + g + \dots + g^{n-1}\} \in S$  is such that  $X * Y = \{0\}$ .

Take  $A = \{1 - g^r\}$  ( $r \neq 0, r > 1$ ) in  $S$ .

$$A * Y = \{0\}.$$

Let  $B = \{3 + 3g + \dots + 3g^{n-1}\} \in S$  then  $B * X = \{0\}$ .

Thus  $S$  has  $S$ -subset weak divisors of zero we can as in case of usual non associative rings define in case of subset non associative ring  $S$ .

We just say a proper subset subsemiring  $P$  of the subset semiring.  $S$  is normal subset subsemiring with respect to a subset  $T$  of  $S$  if  $X * S = S * X$  for all  $X \in T$ .

$$X * (Y * S) = (X * Y) * S$$

$$(S * X) * Y = S * (X * Y) \text{ for all } X, Y \in T.$$

If  $T = S$  we say the subset subsemiring  $P$  is a normal subset subsemiring of  $S$ .

We will just give an example of a Smarandache subset ideal.

**Example 3.52:** Let  $S = \{\text{Collection of all subsets of the loop ring } Z_2L \text{ where } L \text{ is as follows:}$

*	e	g <sub>1</sub>	g <sub>2</sub>	g <sub>3</sub>	g <sub>4</sub>	g <sub>5</sub>
e	e	g <sub>1</sub>	g <sub>2</sub>	g <sub>3</sub>	g <sub>4</sub>	g <sub>5</sub>
g <sub>1</sub>	g <sub>1</sub>	e	g <sub>3</sub>	g <sub>5</sub>	g <sub>2</sub>	g <sub>4</sub>
g <sub>2</sub>	g <sub>2</sub>	g <sub>3</sub>	e	g <sub>4</sub>	g <sub>1</sub>	g <sub>3</sub>
g <sub>3</sub>	g <sub>3</sub>	g <sub>5</sub>	g <sub>4</sub>	e	g <sub>5</sub>	g <sub>2</sub>
g <sub>4</sub>	g <sub>4</sub>	g <sub>2</sub>	g <sub>1</sub>	g <sub>2</sub>	e	g <sub>1</sub>
g <sub>5</sub>	g <sub>5</sub>	g <sub>4</sub>	g <sub>3</sub>	g <sub>1</sub>	g <sub>3</sub>	e

be the subset semiring.

We see S has both S-subset semiring right ideal, right subset semiring ideals, subset semiring ideals and S-subset semiring ideals.

We just recall as in case of usual non associative ring in case of subset non associative semiring S define subset semiidempotents of S.

Let S be a subset non associative semiring of a loop ring RL. A subset  $A \in S \setminus \{0\}$  is said to be a subset semiidempotent if and only if A is not in the two sided subset semiring ideal of S generated by  $A * A - A$ , that is  $A \notin A * S * A$  or  $A * S * A = S$ .

We see A is a Smarandache subset idempotent of S if in S if the Smarandache subset semiring ideal generated  $A^2 - A$  does not contain A.

It is to be noted in a subset non associative semiring a Smarandache subset semiidempotent A of S is a subset semi idempotent but a subset semiidempotent in general is not a Smarandache subset semiidempotent.

**Example 3.53:** Let S = {Collection of all subsets of the loop ring RL where L is given by the following table;

*	1	a	b	c	d	e
1	1	a	b	c	d	e
a	a	1	d	b	e	c
b	b	d	1	e	c	a
c	c	b	e	1	a	d
d	d	e	c	a	1	b
e	e	c	a	d	b	1

be the subset loop semiring of the loop ring RL.

The subset loop semiring S has

$$A_1 = \left\{ \frac{3+a}{2} \right\}, A_2 = \left\{ \frac{3+b}{2} \right\}, A_3 = \left\{ \frac{3+c}{2} \right\},$$

$$A_4 = \left\{ \frac{3+d}{2} \right\} \text{ and } A_5 = \left\{ \frac{3+e}{2} \right\}$$

to be some of its subset idempotents.

Recall we say  $\{x\}$  is a subset unit in S if  $\{x\} * \{y\} = \{1\}$ .

In view of this we have the following theorem.

**THEOREM 3.11:** *Let  $S = \{ \text{Collection of all subsets of a loop ring } KL \text{ where } K \text{ is a field} \}$  be the subset loop semiring of the loop ring KL. If  $A \in S$  is a subset semiidempotent of S with  $|A| = 1$  then  $A - \{1\} = \{x-1\} \in S$  is not a subset unit of S.*

**Proof:** Given S is a subset loop semiring of the loop ring KL. Let  $A = \{x\} \in S$  be a subset semiidempotent in S then  $A - \{1\} = \{x - 1\}$  is not a subset unit in S. For if  $\{x - 1\}$  is a subset unit of S we see  $\{x - 1\} * \{y\} = \{1\}$  in S.

Thus we will have

$$\begin{aligned}
 A^2 - A &= \{x^2\} - \{x\} \\
 &= \{x^2 - x\} \\
 &= \{x(x-1)\} \\
 &= \{x\} * \{x-1\} \\
 &= \{A\} * \{B\} \quad (B = \{x-1\}).
 \end{aligned}$$

We have B to be a subset unit so there exist  $C = \{y\}$  in S with  $B * C = \{1\}$ .

Now the subset ideal generated by  $(A^2 - A) S \neq S$  as A is a subset semiidempotent and  $A \notin \{A^2 - A\}$ . So  $A - \{1\}$  is not a subset unit of S.

**Corollary 3.2:** In the above theorem the cardinality of the subset A in S is 1 is essential. For if  $|A| \neq 1$  then  $|A^2|$  will be greater than 1 and so we can even find units.

We however leave it as a open problem to analyse theorem if  $|A| = n \neq 1$  in S.

We just recall the definition of Smarandache subset semiidempotents of a subset loop semiring S of a loop ring KL.

Let S be a subset loop semiring of a loop ring RL. A subset  $A \in S$  which is a subset semiidempotent is called a Smarandache subset semiidempotent (S-subset semiidempotent) if in S the S-subset semiring ideal generated by  $A^2 - A$  does not contain A.

However we just give the following theorem without proof.

**THEOREM 3.12:** *Let S be a subset loop semiring of the loop ring. All S-subset semiidempotents in S are subset semiidempotents.*

The proof is direct and hence left as an exercise to the reader.



Let  $S$  be the subset loop semiring of a loop ring  $RL$ .

$L^* = 1 + U_S$  where  $U_S = \{A \in S \mid A = \{\alpha_1, \dots, \alpha_n\}$  where  $\alpha_i \in RL; \sum a_i = 0, \alpha_i = \sum_i a_i m_i, 1 \leq i \leq n\}$  is the subset mod  $p$  envelope of  $L$ .

We will first illustrate this by some examples.

**Example 3.54:** Let  $S = \{\text{Collection of all subsets of the loop ring } Z_2L \text{ where } L \text{ is a loop given by the following table};$

*		1		a		b		c		d
1		1		a		b		c		d
a		a		d		c		1		b
b		b		1		d		a		c
c		c		b		1		d		a
d		d		c		a		b		1

be the subset loop semiring of the loop ring  $Z_2L$ .

$S^* = 1 + U_S$  where  $U_S = \{\text{Collection of all subsets from the set } U = \{0, 1 + a, 1 + b, 1 + c, \dots, d + c, 1 + a + b + c, \dots, a + b + c + d\}\}; S^*$  is the subset mod  $p$  envelop of  $L$ .

**Example 3.55:** Let  $S = \{\text{Collection of all subsets of the loop ring } Z_4L_5(2)\}$  be the subset loop semiring of the loop ring  $Z_4L_5(2)$  ( $L_5(2) = \{a_1, a_2, a_3, a_4, a_5, e\}$ );  $S^* = 1 + U_S$  where  $U_S = \{\text{Collection of all subsets from } \{0, 3 + a_1, 3 + a_2, \dots, 2a_1 + 2a_2 + 3a_3 + 3a_4 + 2a_5 \text{ and so on}\}\}$ .

$S^*$  is the subset mod  $p$  envelope of the subset loop ring.

**Example 3.56:** Let  $S = \{\text{Collection of all subsets of the loop ring } Z_3L_{19}(7)\}$  be the subset loop semiring of the loop ring  $Z_3L_{19}(7)$ .

$S^* = 1 + U_S$  where  $U_S = \{ \text{Collection of all subsets from } \{0, 2e + a_1, a_1 + e, a_1 + a_2 + a_3, \dots, 2a_1 + a_2 + a_3 + 2a_4 \text{ and so on} \} \}$ .  $S^*$  is the subset mod p-envelope of the subset loop ring.

Now we give some of the related theorems.

**THEOREM 3.13:** *Let  $L$  be a commutative loop of order  $2n$  in which the square of every element is one and let  $K = \{0, 1\}$ .  $KL$  be the loop ring.  $S^*$  is a subset loop semiring such that every element in every subset  $S^*$  is one and order of  $S^*$  is  $2^{(2^{2n-1})}$ .*

The proof is left as an exercise to the reader.

**THEOREM 3.14:** *Let  $L$  be a loop of order  $2n + 1$ , commutative or otherwise;  $K = \{0, 1\}$  be the prime field of characteristic two,  $KL$  be the loop ring.  $S^* = 1 + U^*$  be the mod p-envelope of  $L$  is a groupoid.  $S^*$  is a subset groupoid of order  $2^{2^n}$ .*

This proof is also left as an exercise to the reader.

**THEOREM 3.15:** *Let  $L$  be a finite loop with an element  $x \in L$  such that  $x^2 = 1$ . Let  $Z_p$  be the prime field characteristic  $p, p > 2$ . Let  $S$  be the collection of all subsets of the loop ring  $Z_p L$ .*

*Then  $S^*$  is the subset groupoid with a nontrivial subset idempotent in it and order of  $S^*$  is  $2^{p^{n-1}}$  where  $|L| = n$ .*

This proof is also direct and hence left as an exercise to the reader.

Now we define the notion of Smarandache subset mod p-envelope of  $L$ .

Let  $L$  be a S-loop and  $K$  any field,  $KL$  the loop ring.

$S = \{ \text{Collection of all subsets of the loop ring } KL \}$  be the subset loop semiring of the loop ring  $KL$ .

A be a S-subloop of L.

The subset mod p-envelope of A of L denoted by  $S(S^*(A)) = SS^*(A)$  is defined as the Smarandache subset mod p-envelope in L. Infact S-subset mod p-envelope  $S(S^*(A))$  is not unique.

We have as many number of S-subloops in L. Further if L has no S-subloop then S-subset mod p-envelope is a empty set.

Other concepts like strongly right commutative subset loop semiring, subset orthogonal semiring ideals, S-subset orthogonal semiring ideals so on; can be defined in an analogous way with appropriate simple modifications.

Let  $S = \{\text{Collection of all subsets of the loop ring } ZL_n(m)\}$  be the subset non associative semiring of the loop ring  $ZL_n(m)$ . We see S is just a collection of subsets.

Thus we can define  $\cup$  and  $\cap$  on  $S'$  and  $T = (S', \cup, \cap)$  can be realized as a subset topological space and this topological space with this usual topology will be known as the usual subset semiring topological space of the subset semiring or the usual topological space associated with the subset semiring ( $S' = S \cup \{\phi\}$ ).

Now we see  $T = (S, \cup, \cap)$  is an infinite topological space and we of course adjoin with S the empty set  $\phi$  for if we have  $A = \{e + g_1 + g_2\}$  and  $B = \{\{0\}, 3e + g_2 + 5g_5 + 8g_9 - 4g_3\} \in S$  then  $A \cup B = \{e + g_1 + g_2, \{0\}, 3e + g_2 + 5g_5 + 8g_9 - 4g_3\} \in S$  by  $A \cap B = \{\phi\}$ . That is why we conditionally in T adjoin this empty set.

Thus we can realize  $S \cup \{\phi\} = P(ZL_n(m))$  that is the power set of the set  $ZL_n(m)$ .

Now we can also define on S a new subset topology  $T_n = (S, \cup_n, \cap_n)$  here we need not adjoin the element  $\phi$  to S, here for any  $A, B \in S, A \cup_n B = \{a + b \mid a \in A \text{ and } b \in B\}$  the usual addition in the loop ring is taken as the operation  $\cup_n$ .

Thus if  $A = \{8e - 9g_1 + 10g_2 + 5g_3 - g_6, 9e + 10g_5, 18e\}$  and  $B = \{e - 4g_7, 10e + g_5, g_2 + 4e\} \in S$ , then  $A \cup_n B = \{9e - 13g_1 + 10g_2 + 5g_3 - g_6, 10e - 4g_1 + 10g_5, 19e - 4g_1, 18e + g_5 - 9g_1 + 10g_2 + 5g_3 - g_6, 19e + 11g_5, 28e + g_5, 22e + g_2 + 13e + g_2 + 10g_5 + 12e - 9g_1 + 11g_2 + 5g_3 - g_6\} \in S$ .

In the first place it is interesting to observe that  $A \cup B \neq A \cup_n A$  thus the operation  $\cup$  and  $\cup_n$  are different not only that we have for ‘ $\cup$ ’ usual topology the empty set is adjoined.

Let  $A = \{5e + g_2\}$  and  $B = \{3e - g_1\} \in S$ .

We know  $A \cap B = \emptyset$ .

$$\begin{aligned} \text{But } A \cap_n B &= \{5e + g_2\} \cap_n \{3e - g_1\} \\ &= \{(5e - g_2) * (3e - g_1)\} \\ &= \{15e - 3g_2 - 5g_1 + g_1 * g_2\} \in S. \end{aligned}$$

Clearly  $A \cap B \neq A \cap_n B$ .

We denote by  $\cup_n$  and  $\cap_n$  the operations on  $S$  and  $T_n = \{S, \cup_n, \cap_n\}$  is a topological space defined as the new non associative subset topological semiring space of the subset non associative semiring.

We further wish to record that in general  $A \cup_n A \neq A$  and  $A \cap_n A \neq A$ .

For take  $A = \{3e - 4g_1 + 5g_2, 8e + 4g_3\} \in S$ .

We see  $A \cup_n A = \{6e - 4g_1 + 10g_2, 16e + 8g_3, 11e - 4g_1 + 5g_2 + 4g_3\} \neq A$ .

However  $A \cup A = A$ .

Consider

$$\begin{aligned} A \cap_n A &= \{(3e - 4g_1 + 5g_2) (3e - 4g_1 + 5g_2), \\ &\quad (8e + 4g_3) * (8e + 4g_3) (3e - 4g_1 + 5g_2) * (8e + 4g_3), \\ &\quad (8e + 4g_3) * (3e - 4g_1 + 5g_2)\} \end{aligned}$$

$$= \{(9e - 12g_1 + 15g_2 - 12g_1 + 16e - 20g_1 * g_2 + 15g_2 - 20g_1 * g_2 + 25e), (64 + 32g_3 + 3g_3 + 16e), (24e - 32g_1 + 40g_2 + 12g_3 - 16g_1 * g_3 + 20g_2 * g_3), (24e + 12g_3 - 32g_1 - 16g_3 * g_1 + 40g_2 + 20(g_3 * g_2))\} \neq A$$

and  $A \cap_n A \neq A \cap A$ .

Thus  $T_n = (S, \cup_n, \cap_n)$  gives a new non associative and non commutative topological space of subset non associative semiring. Infact  $T_n$  is both non associative and non commutative in general.

If the underlying loop ring is commutative then only  $T_n$  will be a commutative new topological space of subset semiring.

**Example 3.57:** Let

$S = \{\text{Collection of all subsets of the loop ring } Z_6L_5(2)\}$  be the subset loop semiring of the loop ring  $Z_6L_5(2)$ .

$(S', \cup, \cap)$  is a subset topological loop semiring space of  $S'$  where  $S' = S \cup \phi$ .  $(S, \cup_n, \cap_n)$  is a subset new non associative topological loop semiring space of  $S$ .

Both  $S$  and  $S'$  are of finite order.

**Example 3.58:** Let  $S = \{\text{Collection of all subsets of the loop semiring } (Z^+ \cup \{0\}) (L_{19}(3))\}$  be the subset loop semiring of the loop semiring  $(Z^+ \cup \{0\}) (L_{19}(3))$ .

$T = (S', \cup_n, \cap_n)$  is an infinite subset new non associative topological loop semiring space of  $S$ .

We see if  $A, B \in T$  then  $A \cap B = B \cap A, A \cup B = B \cup A, A \cap A = A$  and  $A \cup A = A$ .

However if  $A, B \in T_n$  then  $A \cap_n A \neq A$  in general  $B \cup_n B \neq B$  in general and  $A \cap_n B \neq B \cap_n A$ . This is the striking difference between the two spaces.

**Example 3.59:** Let  $S = \{\text{Collection of all subsets of the loop semiring } LL_9(8) \text{ where } L =$

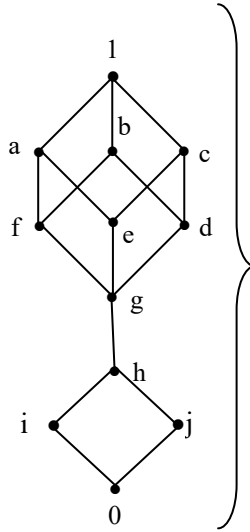

$T = \{S', \cup, \cap\}$  is a finite subset topological space of loop semiring.

$T_n = \{S, \cup_n, \cap_n\}$  is also a finite subset new non associative topological space of loop semiring.

In  $T_n$  ;  $A \cap_n A \neq A$ ,  $A \cap_n B \neq B \cap_n A$  and  $A \cup_n A \neq A$ .

**Example 3.60:** Let  $S = \{\text{Collection of all subsets of the loop ring } (Z_8 \times Z_6) (L_7(3) \times L_5(3)) \}$  be the subset loop semiring of the loop ring  $A$ .

$T = (S', \cup, \cap)$  be the subset topological space of loop semiring of finite order.

$T_n = (S, \cup_n, \cap_n)$  be the subset topological space of the loop semiring of finite order.

$A \cap_n A \neq A$ ,  $A \cup_n A \neq A$  and  $A \cap_n B \neq B \cap_n A$ . Both the subset topological spaces are of finite order.

**Example 3.61:** Let

$S = \{\text{Collection of all subsets of the loop semiring } LL_{27}(11)\}$  be the subset loop semiring of the loop semiring  $LL_{27}(11)$  where  $L =$

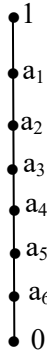

Let  $T = (S', \cup, \cap)$  is a finite subset topological semiring space.  $T_n = (S, \cup_n, \cap_n)$  is also a finite new subset non associative topological semiring space.

**Example 3.62:** Let  $S = \{\text{collection of all subsets of the loop semiring } (L_1 \times L_2) (L_{83}(12)) = M\}$  be the subset loop semiring of the loop semiring  $M = (L_1 \times L_2) L_{83}(12)$  where

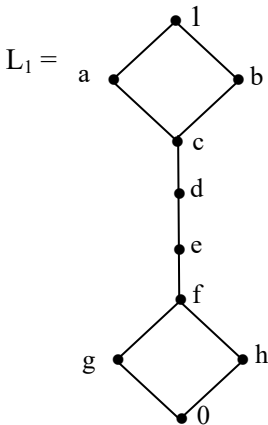

and  $L_2 =$

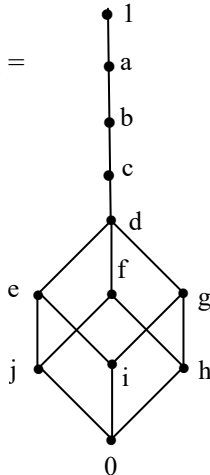

We see  $T = (S', \cup, \cap)$  is a subset topological loop semiring space of finite order. Also  $T_n = (S, \cup_n, \cap_n)$  is a subset new non associative topological loop semiring space of finite order. Both the topological spaces are distinct.

Now we see the subset topological space  $T = (S', \cup, \cap)$  of the subset loop semiring behaves just like the usual topology on subsets of a loop ring (or loop semiring), however the subset new topological space of the subset loop semiring  $S$  is very different for  $A \cap_n A \neq A$ ,  $A \cup_n A \neq A$ ,  $A \cup_n B = B \cup_n A$  but  $A \cap_n B \neq B \cap_n A$  and  $A \cap_n (B \cap_n C) \neq (A \cap_n B) \cap_n C$  for  $A, B, C \in S$ .

Now we can as in case of usual topological spaces find topological subspaces.

We will illustrate this situation in case of both the subset topologies  $T$  and  $T_n$ .

**Example 3.63:** Let

$S = \{\text{Collection of all subsets of the loop ring } Z_{11}L_{35}(9)\}$  be the subset loop semiring of the loop ring  $Z_{11}L_{35}(9)$ .

Now  $H_i(7) = \{e, i, 7 + i, i + 2 \times 7, i + 3 \times 7, i + 4 \times 7\}$  for  $i = 1$ , we get  $H_1(7) = \{e, 1, 8, 15, 22, 29\}$  true for  $1 \leq i \leq 7$ .

Let

$M_i = \{\text{Collection of all subsets of the subloop ring } Z_{11}H_i(7)\}$  be the subset subloop subsemiring of the subloop ring  $Z_{11}H_i(7)$ ,  $1 \leq i \leq 7$ .

Now  $T_i = \{M'_i, \cup, \cap\}$  is a subset subloop semiring topological subspace of  $T$  of  $M_i$ ,  $1 \leq i \leq 7$  where  $T = \{S', \cup, \cap\}$ . Thus now we have given seven subset topological loop semiring subspaces of  $T$ .



Consider the subloops  $M_i(5) = \{e, i, 5 + i, i + 2 \times 5, i + 3 \times 5, i + 4 \times 5, i + 5 \times 5, i + 6 \times 5\} \subseteq L_{35}(9)$ , for  $1 \leq i \leq 4$  are all subloop of  $L_{35}(9)$ .

For  $i = 2$  we have  $M_2(5) = \{e, 2, 7, 12, 17, 22, 27, 32\}$  is a subloop of  $L_{35}(9)$ .

Let

$V_i = \{\text{Collection of all subsets of the subloop semiring } Z_{11}M_i(5)\}; (1 \leq i \leq 5)$  be the subset loop subsemiring of  $S$ . Suppose  $B_i = \{V'_i, \cup, \cap\}$  be the subset topological subspace of subsemiring of  $T$ . We see we have 5 more subset topological loop subsemiring subspaces of  $T$ .

Now consider  $C_i = \{e, i\}$  where  $i \in L_{35}(9) \setminus \{e\}$ . We see  $Z_{11}C_i$  is a subloop ring in  $Z_{11}L_{35}(9)$ .

Take

$A_i = \{\text{Collection of all subsets of the subloop ring } Z_{11}C_i\}$  to be the subset loop subsemiring of  $S$ ;  $1 \leq i \leq 35$ . Suppose  $X_i = \{A'_i, \cup, \cap\}$ , then we see  $X_i$  are subset topological subspaces of  $S$  and there are 35 such subspaces in  $T$  using  $S$ . Thus we have atleast  $35 + 5 + 7 = 47$  subset topological subloop semiring subspaces of  $T = (S', \cup, \cap)$ .

Now what can be said about new subset topological loop semiring subspaces. We can say we have 47 subset new topological subloop semiring subspaces of which 35 of them are associative i.e.,  $(A \cap_n B) \cap_n C = A \cap_n (B \cap_n C)$  for all  $A, B, C \in A_i; 1 \leq i \leq 35$ .

Thus  $X_i^n = \{A_i, \cup_n, \cap_n\}$  are a collection of all subset new topological loop semiring subspaces which are associative with respect to the operation  $\cap_n, 1 \leq i \leq 35$ .

**Example 3.64:** Let

$S = \{\text{Collection of all subsets of the loop ring } Z_5L_7(6)\}$  be the subset loop semiring of the loop ring  $Z_5L_7(6)$ .

We see we have seven subloops all of them are subgroups given by  $V_i = \{\text{Collections of all subsets of the subloop ring } Z_5M_i \text{ where } M_i = \{e, i\}, i \in L_7(6) \setminus \{e\}\}$  is a subset loop subsemiring of  $S$ .  $T_i = \{V'_i, \cup, \cap\}$  is a subset topological loop semiring subspace of  $T = \{S', \cup, \cap\}, (V'_i = V_i \cup \{\phi\})$  we further see  $T_n = \{S, \cup_n, \cap_n\}$  is the subset new non associative topological space loop semiring.

We see  $\{V_i, \cap_n, \cup_n\} \subseteq T_n$  is a subset new topological subspace of  $T_n$  but all these  $\{V_i, \cap_n, \cup_n\}$  are associative with respect to  $\cap_n$  however  $A \cup_n A \neq A$  and  $A \cap_n A \neq A$  for all  $A \in V_i$ .

**Example 3.65:** Let

$S = \{\text{Collection of all subsets of the loop ring } Z_{12}L_5(3)\}$  be the subset loop semiring of the loop ring  $Z_{12}L_5(3)$ . We see we have more than 5 subset topological loop semiring subspaces of  $T = \{S', \cup, \cap\}$  and more than 5 subset new non associative topological loop semiring subspaces of  $T_n = \{S, \cup_n, \cap_n\}$ , however all of these new subset topological loop semiring subspaces are associative with respect to  $\cap_n$ .

The other possible subset topological loop semiring subspaces are;

$W_1 = \{\text{Collection of all subsets of the loop ring } 2Z_{12}L_5(3)\}$  be the subset loop subsemiring of  $S$ .

$W_2 = \{\text{Collection of all subsets of the loop ring } 3Z_{12}L_5(3)\}$  be the subset loop subsemiring of  $S$ .

$W_3 = \{\text{Collection of all subsets of the loop ring } 4Z_{12}L_{15}(3)\}$  be the subset loop subsemiring of  $S$ .

$W_4 = \{\text{Collection of all subsets of the loop ring } 6Z_{12}L_5(3)\}$  be the subset loop subsemiring of  $S$ .

Thus  $W_1, W_2, W_3$  are  $W_4$  are subset loop subsemiring of  $S$ . We see if  $Y_i = \{W'_i, \cup, \cap\} \subseteq T = \{S', \cup, \cap\}$ ,  $1 \leq i \leq p$  then they are subset loop topological subspaces of  $T$ .

$Z_i = \{W_i, \cup_n, \cap_n\}$  are all subset new non associative topological subspaces of the loop semiring of the subset new topological space  $T_n = \{S, \cup_n, \cap_n\}$ .

Here also it is pertinent to keep on record that none of these new non associative topological loop semiring subspaces are infact non associative with respect to the operation  $\cap_n$ .

Now let us consider  $D_i = \{\text{Collection of all subsets of the subloop ring } 2Z_{12}P_i, \text{ where } P_i = \{e, i\} \text{ and } i \in L_5(3) \setminus \{e\}\}$ ,  $1 \leq i \leq 5$ , the subset loop subsemiring of  $S$ .

Let  $E_i = \{D'_i, \cup, \cap\}$  be the subset topological loop semiring subspaces of  $T = \{S, \cup, \cap\}$ ;  $1 \leq i \leq 5$ .

$F_i = \{D_i, \cup_n, \cap_n\} \subseteq T_n = \{S, \cup_n, \cap_n\}$  are subset new topological non associative loop semiring subspaces of  $T_n$ .

We see all these  $F_i$ 's are associative new topological loop semiring subspaces of  $T$ .

**Example 3.66:** Let  $S = \{\text{Collection of all subsets of the loop ring } Z_{15}L_{19}(8)\}$  be the subset loop semiring of the loop ring  $Z_{15}L_{19}(8)$ .

We see  $L_{19}(8)$  has no subloops which are different from subgroups. Infact  $L_{19}(8)$  has 19 distinct subgroups which are subloops.

Further we see;

$A_1 = \{\text{all subsets of the loop subring } 3Z_{15}L_{19}(8)\}$  be the subset loop subsemiring of  $S$ .

Let  $A_2 = \{\text{all subsets of the loop subring } 5Z_{15}L_{19}(8)\}$  be the subset loop subsemiring of  $S$ .

$B_1 = \{A'_1, \cup, \cap\}$  and  $B_2 = \{A'_2, \cup, \cap\}$  are subset topological loop subsemiring subspaces of  $T = \{S, \cup, \cap\}$ .

$C_n^1 = \{A_1, \cup_n, \cap_n\}$  and  $C_n^2 = \{A_2, \cup_n, \cap_n\}$  are new subset topological loop subsemiring subspaces of  $T_n = \{S, \cup_n, \cap_n\}$ .

We see both the new subset spaces topological subspaces are non associative.

Consider

$G_1 = \{\text{Collection of all subsets of the loop subring } 3Z_{15}P_i\}$  ( $P_i = \{e, i\}; i \in L_{19}(8) \setminus \{e\}$ ) the subset loop subsemiring of  $S$ .  $H_i = (G'_i, \cap, \cup)$  is the subset topological loop semiring subspace of  $S; 1 \leq i \leq 19$ .

$J_i = \{G_i, \cup_n, \cap_n\} \subseteq S$  is the subset new topological loop subsemiring subspaces of  $(T_n, \cup_n, \cap_n), 1 \leq i \leq 19$ .

All these 19 subset new topological subspaces are associative with respect to the operation  $\cap_n$ .

However it is once again pertinent to keep on record that  $L_{19}(8)$  has no proper subloops which are different from subgroups.

**Example 3.67:** Let

$S = \{\text{Collection of all subsets of the loop ring } Z_{10}L_{35}(9)\}$  be the subset loop semiring of the loop ring  $Z_{10}L_{35}(9)$ .

Take  $P_i = \{\{e, i\} \subseteq L_{35}(9); i \in L_{35}(9) \setminus \{e\};$  be the subloops (which are subgroups of  $L_{35}(9)$ );  $1 \leq i \leq 35$ .

$B_i = \{\text{Collection of all subsets of the loop subring } L_{35}(9) P_i\}, 1 \leq i \leq 35.$   $C_i = \{B'_i, \cap, \cup\} \subseteq T = \{S', \cup, \cap\}$  are all subset topological loop semiring subspaces of  $T, 1 \leq i \leq 35$ .

Similarly  $D_i = \{B_i, \cap_n, \cup_n\} \subseteq T_n = \{S, \cup_n, \cap_n\}$  are all subset new topological loop semiring subspaces of  $T_n$ ;  $1 \leq i \leq 35$ .

None of these subset new topological loop semiring subspaces are non associative under  $\cap_n$ , infact all these 35 subspaces are associative under  $\cap_n$ .

Now consider  $G_i = \{\text{Collection of all subsets of the loop subring } 2Z_{10}P_i; 1 \leq i \leq 35\} \subseteq S$  be the subset loop subsemiring of  $S$ .

We have 35 such subset loop subsemirings.

$H_i = \{G'_i, \cup, \cap\} \subseteq T = \{S, \cup, \cap\}$ ,  $1 \leq i \leq 35$  are all subset topological loop semiring subspace of  $\{T, \cup, \cap\}$ .

$J_i = \{G_i, \cup_n, \cap_n\} \subseteq T_n = \{S, \cup_n, \cap_n\}$  are the subset new topological loop semiring subspaces of  $\{S, \cup_n, \cap_n\}$  and all of them are associative under the operation  $\cap_n$ .

Take  $K_i = \{\text{Collection of all subsets of the loop semiring } 5Z_{10}P_i\} \subseteq S$ , be the subset loop subsemiring of  $S$ .

$L_i = \{K'_i, \cap, \cup\} \subseteq T = \{S, \cup, \cap\}$  is a subset topological loop semiring subspace of  $T$ ;  $1 \leq i \leq n$ .

We have  $M_i = \{K_i, \cap_n, \cup_n\} \subseteq T_n = \{S, \cup_n, \cap_n\}$  is a subset non associative new topological loop semiring subspace of  $T_n$ . We have 35 in number and all of them are associative under the operation  $\cap_n$ .

Let  $N_i = \{\text{Collection of all subsets of the loop ring } Z_{10}H_i(7); 1 \leq i \leq 7\} \subseteq S$ ; be the subset loop subsemiring of  $S$ .

$O_i = \{N'_i, \cap, \cup\} \subseteq T = \{S', \cup, \cap\}$  is the subset topological loop semiring subspace of  $T$  and they are seven in number.

$P_i = \{N_i, \cap_n, \cup_n\} \subseteq T_n = \{S, \cup_n, \cap_n\}$  are subset new topological loop semiring subspaces all of which are non associative with respect to  $\cap_n$ .

Let  $Q_i = \{\text{Collection of all subsets of the loop subring } Z_{10}H_i(5); 1 \leq i \leq 5\} \subseteq S$  be the subset loop subsemiring of  $S$ .

$R_i = \{Q'_i, \cap, \cup\} \subseteq T = \{S', \cup, \cap\}$  are the subset topological loop semiring subspaces of  $T$ .

$T_i = \{Q_i, \cup_n, \cap_n\} \subseteq T_n = (S, \cup_n, \cap_n)$  are all subset new topological loop subsemiring subspaces of  $T_n$ .

All these 5 spaces are non associative with respect to  $\cap_n$ .

Let

$U_i = \{\text{collection of all subsets of the loop subring } 5Z_{10}H_i(5)\}$  be the subset loop subsemiring  $\subseteq S, 1 \leq i \leq 5$ .

Let  $V_i = \{U'_i, \cup, \cap\}$  be the subset topological loop semiring subspace of  $T = \{S', \cup, \cap\}$ .

We see  $W_i = \{U_i, \cap_n, \cup_n\} \subseteq T_n = \{S, \cap_n, \cup_n\}$  is a subset new topological loop subsemiring subspaces of  $T_n, 1 \leq i \leq 5$ .

$X_i = \{\text{Collection of all subsets of the loop subring } 5Z_{10}H_i(7)\} \subseteq S$  be the subset loop subsemiring of  $S$ .

$X^i = \{X'_i, \cup, \cap\} \subseteq T = \{S', \cup, \cap\}$  is a subset loop subsemiring topological subspaces of  $T; 1 \leq i \leq 5$ .

$X_n^i = \{X_i, \cap_n, \cup_n\} \subseteq T_n = \{S, \cup_n, \cap_n\}$  is a subset loop subsemiring new topological subspaces of  $T_n; 1 \leq i \leq 7$ .

$Y_i = \{\text{Collection of all subsets of the loop subsemiring } 2Z_{10}H_i(5)\} \subseteq S; 1 \leq i \leq 5$  is a subset loop subsemiring of  $S$ .

$Y_i = \{Y'_i, \cup, \cap\} \subseteq T = \{S', \cup, \cap\}$  is a subset topological loop subsemiring subspaces of  $T$ ,  $1 \leq i \leq 5$ .

$Y_n^i = \{Y_i, \cap_n, \cup_n\} \subseteq T_n = \{S, \cup_n, \cap_n\}$  is the subset new topological loop subsemiring subspaces of the subset new topological space  $T_n$ ,  $1 \leq i \leq 7$ . We see topological subspaces of the subset topological spaces  $T_n$  and  $T$ .

In view of all these we have the following theorems.

**THEOREM 3.16:** *Let  $S = \{Collection\ of\ all\ subsets\ of\ the\ loop\ ring\ } Z_p L_n(m)$ ;  $n$  an odd prime be the subset loop semiring of the loop ring  $Z_p L_n(m)$ ,  $p$  a prime.*

*$S$  has atleast  $n$ -subset topological loop semiring subspaces of  $T = \{S', \cup, \cap\}$  as well as  $n$ -subset new topological loop semiring subspaces of  $T_n = \{S, \cup_n, \cap_n\}$ .*

Proof follows from the simple fact that  $L_n(m)$  has no subloops as  $n$  is an odd prime and only subgroups  $P_i = \{e, i\}$  of order two,  $1 \leq i \leq n$ .

So associated with each  $P_i$  we have  $V_i = \{Collection\ of\ all\ subsets\ of\ the\ loop\ subring\ } Z_p P_i$ ;  $1 \leq i \leq n\} \subseteq S$ , the subset loop subsemiring and  $W_i = \{V'_i, \cup, \cap\} \subseteq T = \{S', \cup, \cap\}$  is a subset topological loop semiring subspace of  $T$ ,  $1 \leq i \leq n$ .

$X_i = \{V_i, \cap_n, \cup_n\} \subseteq T_n = \{S, \cup_n, \cap_n\}$  is a subset new topological loop semiring subspace of  $T_n$ ,  $1 \leq i \leq n$ .

Hence the claim.

It is left as an open problem to find other subset topological loop semiring subspaces and subset new topological loop semiring subspaces.

Further  $R = \{ \text{Collection of all subsets from } P = \left\{ t \sum_{i=1}^n l_i + e, \right.$   
 $l_i \in L_n(m); t = 0, 1, 2, \dots, p \}$  is a subset loop subsemiring of  $S$   
 and  $\{R', \cup, \cap\} = M$  is a subset topological loop semiring  
 subspace of  $T = \{S', \cup, \cap\}$ .  $R_n = \{R, \cup_n, \cap_n\}$  is a subset new  
 topological loop subsemiring of  $T_n = \{S, \cup_n, \cap_n\}$ .

Now we proceed onto describe the other theorems.

**THEOREM 3.17:** *Let  $S = \{ \text{Collection of all subsets of the loop ring } Z_n L_p(m), p \text{ a prime, } n \text{ a composite number} \}$  be the subset loop semiring of the loop ring  $Z_n L_p(m)$ .*

- (i)  *$S$  has atleast  $p + 1$  number of subset loop subsemirings.*
- (ii) *Corresponding to each of the subset loop subsemirings we have an associated subset topological loop semiring subspaces of  $T = \{S', \cup, \cap\}$  and an associated subset new non associative topological loop semiring subspaces of  $T_n = \{S, \cup_n, \cap_n\}$  which are each  $(p+1)$  in number.*
- (iii) *If  $Z_n$  has  $t$  number of subrings then  $T = \{S', \cup, \cap\}$  and  $T_n = (S, \cup_n, \cap_n)$  contains  $t(p+2)$  number of subset topological loop semiring subspaces of  $T$  and  $t(p+2)$  number of subset new topological loop semiring subspaces of  $T_n$  respectively.*

Proof is direct and hence is left as an exercise to the reader.

**THEOREM 3.18:** *Let  $S = \{ \text{Collection of all subsets of the loop ring } Z_t L_n(m), t \text{ a composite number } n \text{ a odd composite number} \}$  be the subset loop semiring of the loop ring  $Z_t L_n(m)$ .*

*If  $Z_t$  has  $s$  number of subring and if  $L_n(m)$  has  $r$  number of subloops including the  $n$  subloops.*

- (i) *Then  $Z_t L_n(m)$  has atleast  $sr$  number of loop subrings.*



- (ii) Associated with each loop subring;  $T = \{S', \cup, \cap\}$  has atleast  $sr$  number of subset topological loop semiring subspaces.
- (iii) Associated with each of the loop subring  $T_n = \{S, \cup_n, \cap_n\}$  has atleast  $sr$  number of subset new topological loop semiring subspaces.

Proof is left as an exercise to the reader.

Now having seen topological subspaces we just indicate we can have neutrosophic analogue in all cases. If we replace  $Z_n$  by  $\langle Z_n \cup I \rangle = \{a + bI \mid a, b \in Z_n, I^2 = I\}$  we get the corresponding subset loop neutrosophic semiring or neutrosophic subset loop semiring.

Similarly replacing  $Z$  by  $\langle Z \cup I \rangle$ ,  $Q$  by  $\langle Q \cup I \rangle$ ,  $R$  by  $\langle R \cup I \rangle$  and  $C$  by  $\langle C \cup I \rangle$  we can get neutrosophic loop ring using appropriate loops over these rings.

Further replacing  $Z^+ \cup \{0\}$  by  $\langle Z^+ \cup I \rangle \cup \{0\}$ ,  $Q^+ \cup \{0\}$  by  $\langle Q^+ \cup I \rangle \cup \{0\}$ ,  $R^+ \cup \{0\}$  by  $\langle R^+ \cup I \rangle \cup \{0\}$  we get neutrosophic loop semirings using appropriate loops over these semirings.

Finally replacing  $C(Z_n)$  by  $\langle C(Z_n) \cup I \rangle$  we get neutrosophic complex finite modulo integer loop semirings  $\langle C(Z_n) \cup I \rangle L$  where  $L$  is a loops.

All properties can be studied for these subset neutrosophic loop semirings which is treated as a matter of routine.

However we give some examples of them.

**Example 3.68:** Let  $S = \{\text{Collection of all subsets of the neutrosophic loop ring } \langle Z_5 \cup I \rangle L_9(8)\}$  be the neutrosophic subset loop semiring of the neutrosophic loop ring.

**Example 3.69:** Let  $S = \{\text{Collection of all subsets of the neutrosophic loop ring } \langle Z \cup I \rangle L_{15}(8)\}$  be the neutrosophic

subset loop semiring of the neutrosophic loop ring. Clearly  $S$  is of infinite order.

**Example 3.70:** Let  $S = \{\text{Collection of all subsets of the neutrosophic complex loop ring } \langle C \cup I \rangle_{L_{23}(8)}\}$  be the subset neutrosophic complex loop semiring of infinite order.

**Example 3.71:** Let  $S = \{\text{Collection of all finite complex neutrosophic ring. } \langle Z_{27} \cup I \rangle_{L_{27}(8)}\}$  be the subset finite complex modulo integer neutrosophic loop semiring of finite order.

**Example 3.72:** Let  $S = \{\text{Collection of all subsets of the neutrosophic loop ring } \langle Z_{20} \cup I \rangle (g_1, g_2) L_{11}(4); g_1^2 = 0, g_2^2 = g_2, g_1g_1 = g_2g_1 = 0\}$  be the subset neutrosophic loop semiring of the neutrosophic loop ring  $(\langle Z_{20} \cup I \rangle) (g_1, g_2) L_{11}(4)$  of finite order.

**Example 3.73:** Let  $S = \{\text{Collection of all subsets of the neutrosophic loop ring } \langle Z^+ \cup \{0\} \rangle_{L_{29}(11)}\}$  be the subset neutrosophic loop semiring of infinite order.

**Example 3.74:** Let  $S = \{\text{Collection of all subsets of the neutrosophic loop semiring } \langle R^+ \cup \{0\} \rangle(g)_{L_{29}(8)}\}$  where  $g^2 = 0$  be the subset neutrosophic loop semiring of infinite order.

Now having seen examples of neutrosophic subset loop semiring of the loop semiring, we now give some examples of substructures.

**Example 3.75:** Let  $S = \{\text{Collection of all subsets of the neutrosophic loop ring } \langle Z_7 \cup I \rangle_{L_{21}(11)}\}$  be the subset neutrosophic loop semiring of neutrosophic loop ring  $\langle Z_7 \cup I \rangle_{L_{21}(11)}$ .  $S$  has subset loop subsemirings which are not neutrosophic for  $Z_7L_{21}(11)$ ,  $Z_7H_i(7)$ ,  $1 \leq i \leq 7$  and  $Z_7H_i(3)$ ,  $1 \leq i \leq 3$  are loop subrings which are not neutrosophic so associated with these we get the subset loop subsemirings which are not neutrosophic. Thus we have 11 of them which does not include the 21 subset loop subsemirings obtained from the loop subrings  $Z_7P_i$ ;  $P_i = \{e, i\}$ ,  $i \in L_{21}(11)$ ,  $1 \leq i \leq 21$ .

**Example 3.76:** Let  $S = \{\text{Collection of all subsets of the neutrosophic loop ring } \langle Z_{12} \cup I \rangle L_5(3)\}$  be the subset neutrosophic loop semiring of the neutrosophic loop ring.  $S$  has both subset neutrosophic loop subsemiring as well as subset loop subsemirings which are not neutrosophic. Take  $P^i = \{\text{Collection of all subsets of the neutrosophic loop subring } \langle Z_{12} \cup I \rangle P_i, P_i = \{e, i\}, i \in L_5(3) \setminus \{e\}, 1 \leq i \leq 5\}$  are the five subset neutrosophic loop subsemiring.

Consider  $M_i = \{\text{Collection of subsets of the neutrosophic loop ring } \langle 2Z_{12} \cup I \rangle P_i\}; 1 \leq i \leq 5$  is the subset neutrosophic loop subsemiring.

By replacing in  $M_i, \langle 2Z_{12} \cup I \rangle$  by  $\langle 4Z_{12} \cup I \rangle$  or by  $\langle 6Z_{12} \cup I \rangle$  or by  $\langle 3Z_{12} \cup I \rangle$  we get subset neutrosophic loop subsemirings.

Now  $Z_{12}P_i$  is a loop ring which is not neutrosophic subset loop subsemiring using

$N_i = \{\text{Collection of all subsets of the loop subsemiring } Z_{12}P_i\}; 1 \leq i \leq 5.$

Finally using loop subrings  $2Z_{12}P_i, 3Z_{12}P_i, 4Z_{12}P_i$  and  $6Z_{12}P_i$  in place of  $Z_{12}P_i$  in  $M_i$  we get 20 subset loop subsemirings which are not neutrosophic subset loop subsemirings of  $S$ .

**Example 3.77:** Let  $S = \{\text{Collection of all subsets of the neutrosophic loop ring } \langle Z \cup I \rangle L_{23}(7)\}$  be the subset neutrosophic loop semiring.  $S$  has infinite number of subset neutrosophic loop subsemirings as well as infinite number of subset loop subsemirings which are not neutrosophic.

**Example 3.78:** Let  $S = \{\text{Collection of all subsets of the complex neutrosophic loop ring } \langle C \cup I \rangle L_{29}(9)\}$  be the subset complex neutrosophic loop semiring of the complex neutrosophic loop ring  $\langle C \cup I \rangle L_{29}(9)$ .

$S$  has infinite number of complex neutrosophic subset loop subsemirings.  $S$  has also infinite number of neutrosophic subset loop subsemirings which are not complex and finally  $S$  has

infinite number of complex subset loop subsemirings which are not neutrosophic.

**Example 3.79:** Let  $S = \{\text{Collection of all subsets of the neutrosophic loop ring } \langle \mathbb{Z}_{42} \cup I \rangle L_{29}(8)\}$  be the subset neutrosophic loop semiring.  $S$  has subset zero divisors and has subset neutrosophic loop ring subsemirings.

**Example 3.80:** Let  $S = \{\text{Collection of all subsets of the neutrosophic loop semiring } M = (\langle \mathbb{Z}_{28} \cup I \rangle \times L) L_9(8)\}$  be the subset neutrosophic loop semiring of the neutrosophic loop semiring  $M$ , where  $L$  is a lattice given by

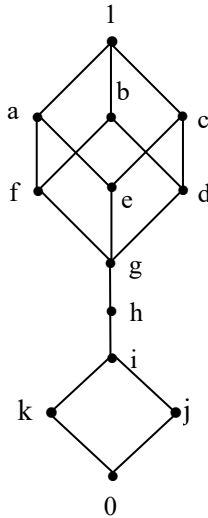

$S$  has subset zero divisors, subset units and subset substructures.

It is a matter of routine to find and study all properties in an analogous way for these subset neutrosophic loop semirings over a neutrosophic loop ring or over a neutrosophic loop semiring. As it is a matter of routine we leave it as an exercise to the reader.

**Example 3.81:** Let  $S = \{\text{Collection of all subsets of the neutrosophic loop ring } \langle \mathbb{Z}_8 \cup I \rangle L_7(3)\}$  be the neutrosophic

subset loop semiring of the neutrosophic loop ring  $\langle Z_8 \cup I \rangle L_7(3)$ .

$T = \{S', \cup, \cap\}$  is defined as the subset neutrosophic topological loop semiring space and  $T_n = \{S, \cup_n, \cap_n\}$  is defined as the subset neutrosophic new non associative topological loop semiring space. We see  $T$  and  $T_n$  are of finite order.

Clearly both  $T$  and  $T_n$  has subset neutrosophic topological subspaces.

**Example 3.82:** Let  $S = \{\text{Collection of all subsets of the neutrosophic loop semiring } (\langle Z^+ \cup I \cup \{0\} \rangle) L_{31}(8)\}$  be the subset neutrosophic loop semiring of the loop semiring.

$\{S', \cup, \cap\}$  is an infinite neutrosophic topological space of the subset loop semiring.  $\{S, \cup_n, \cap_n\}$  is also an infinite subset neutrosophic new non associative topological loop semiring space.

**Example 3.83:** Let  $S = \{\text{Collection of all subsets of the neutrosophic loop ring } M = \langle Z_{25} \cup I \rangle L_{27}(8)\}$  be the subset neutrosophic loop semiring of the neutrosophic loop ring  $M$ .

Let  $T = \{S', \cup, \cap\}$  be the neutrosophic subset topological space of loop semiring.

$T_n = \{S, \cup_n, \cap_n\}$  be the neutrosophic new non associative subset topological loop semiring space.

Both  $T$  and  $T_n$  are of finite order.  $T_n$  is a non associative new topological loop semiring space.

**Example 3.84:** Let  $S = \{\text{Collection of all subsets of the neutrosophic loop ring } M = [\langle C(Z_{45} \cup I) \rangle (g_1, g_2)] L_{45}(8)\}$  be the subset neutrosophic loop semiring of the loop ring  $M$ .

Here  $g_1^2 = 0$ ,  $g_2^2 = g_2$ ,  $g_1g_2 = g_2g_1 = 0$ .  $T = \{S', \cup, \cap\}$  is a subset neutrosophic loop semiring topological space.

$W = \{P', \cup, \cap \mid P' = \{\text{Collection of all subsets of the neutrosophic loop ring } \langle Z_{45} \cup I \rangle L_{45}(8)\} \subseteq T$  is a subset neutrosophic loop semiring topological subspace of  $S$ .

We see  $T$  has several subset neutrosophic loop semiring topological subspaces.

$T_n = \{S, \cup_n, \cap_n\}$  be the subset loop semiring of the new topological space.  $T_n$  also has several subset loop semiring new topological subspaces.  $W_n = \{P, \cap_n, \cup_n\} \subseteq T_n$  is a subset loop semiring new topological subspace of  $T_n$ .

**Example 3.85:** Let  $S = \{\text{Collection of all subsets of the neutrosophic loop ring } W = (\langle Z_8 \cup I \rangle \times \langle Z_{14} \cup I \rangle) L_{29}(8)\}$  be the subset neutrosophic loop semiring of the loop ring  $N$  of finite order.

$T = (S', \cup, \cap)$  be the subset neutrosophic topological loop semiring space.  $T$  has several subset neutrosophic topological loop semiring subspaces. Likewise  $T_n = \{S, \cup_n, \cap_n\}$  be the subset neutrosophic new topological loop semiring space.  $T_n$  also has several subset neutrosophic new topological loop semiring subspaces.

**Example 3.86:** Let  $S = \{\text{Collection of all subsets of the neutrosophic loop semiring } M = \{\langle Z^+ \cup \{0\} \cup I \rangle \times \langle Z_{81} \cup I \rangle \times \langle L \rangle \times \langle Q^+ \cup \{0\} \cup I \rangle\} L_{21}(11)\}$  be the neutrosophic loop semiring of the neutrosophic loop semiring.  $T = \{S', \cup, \cap\}$  is a subset neutrosophic loop topological semiring space.  $T$  has several subset neutrosophic loop topological semiring subspaces.

**Example 3.87:** Let  $S = \{\text{Collection of all subsets of the neutrosophic loop ring } B = \{\langle Z_{18} \cup I \rangle \times \langle Z_{11} \cup I \rangle\} L_{19}(8)\}$  be a subset neutrosophic loop semiring of the neutrosophic loop ring  $B$ .

$T = \{S', \cup, \cap\}$  be the subset neutrosophic topological loop semiring space.

T has several subset neutrosophic topological loop semiring subspaces. T is of finite order.

$T_n = \{S, \cap_n, \cup_n\}$  be the subset neutrosophic new non associative topological loop semiring space. Clearly  $T_n$  has several subset neutrosophic new topological loop semiring subspaces.  $o(T_n) < \infty$ .

Several other interesting properties of subset neutrosophic loop ring topological spaces can be got as in case of subset loop topological spaces. The same holds good in case of new subset neutrosophic loop semiring topological spaces also.

Here we suggest some problems for the reader.

### Problems

1. Find some special features enjoyed by subset non associative semirings of loop rings.
2. Distinguish between the subset non associative semirings of a loop ring and a groupoid ring.
3. Does there exist a subset non associative semiring associated with a loop of infinite order?
4. Let  $S = \{\text{Collection of all subsets of the loop ring } Z_2L_9(8)\}$  be a non associative subset semiring of the loop ring  $Z_2L_9(8)$ .
  - (i) Find  $o(S)$ .
  - (ii) Can S have subset zero divisors?
  - (iii) Is S a Smarandache subset semiring?
  - (iv) Can S have a proper subset which is a subset field?
  - (v) Can S have subset ideals?

- (vi) Can  $S$  have subset  $S$ -ideals?
- (vii) Can  $S$  have subset idempotents?

5. Let  $S = \{\text{Collection of all subsets of the loop ring } Z_{12}L_{19}(7)\}$  be the subset non associative semiring of the loop ring  $Z_{12}L_{19}(7)$ .

Study questions (i) to (vii) of problem (4) for this  $S$ .

6. Let  $S = \{\text{Collection of all subsets of the loop ring } QL_{21}(11)\}$  be the subset non associative semiring of the loop ring  $QL_{21}(11)$ .

Study questions (i) to (vii) problem 4 for this  $S$ .

7. Let  $S_1 = \{\text{Collection of all subsets of the loop semiring } LG = LL_{23}(7)\}$  where  $L$  is given in the following;

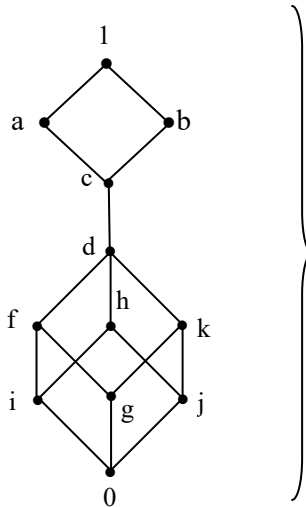

be the subset non associative semiring of the loop semiring  $LL_{23}(7)$ .

Study questions (i) to (vii) of problem (4) for this  $S$ .



8. Let  $S_2 = \{\text{Collection of all subsets of the loop ring } Z_{23}L_{23}(7)\}$  be the subset non associative semiring of the loop ring  $Z_{23}L_{23}(7)$ .

- (i) Study questions (i) to (vii) of problem four for this  $S_2$ .
- (ii) Compare  $S_1$  of problem 7,  $S_3$  of following problem 9 with this  $S_2$ .

9. Let  $S_3 = \{\text{Collection of all subsets of the loop lattice } LL_{23}(7) \text{ where } L =$

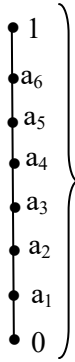

be the subset non associative semiring of the loop lattice  $LL_{23}(7)$ .

- (i) Study questions (i) to (vii) of problem (4) for this  $S_3$ .
- (ii) Compare  $S$  of problem 7 with this  $S_3$ .

10. Let  $S_4 = \{\text{Collection of all subsets of the loop ring } Z_{24}L_{23}(7)\}$  be the subset non associative semiring of the loop ring  $Z_{24}L_{23}(7)$ .

- (i) Study questions (i) to (vii) of problem 4 for this  $S_4$ .
- (ii) Compare  $S$  of problem 7,  $S_3$  of problem 9 and  $S_2$  of problem 8 with this  $S_4$ .

11. Let  $S_5 = \{\text{Collection of all subsets of the loop ring } ZL_{23}(7)\}$  be the subset non associative semiring of the loop ring  $ZL_{23}(7)$ .

- (i) Study questions (i) to (vii) of problem 4 for this  $S_5$ .
- (ii) Compare  $S$  of problem 7,  $S_3$  of problem 9,  $S_2$  of problem 8,  $S_4$  of problem 10 with this  $S_5$ .

12. Let  $S_6 = \{\text{Collection of all subsets of the loop semiring } (Z^+ \cup \{0\})L_{23}(7)\}$  be the subset non associative semiring of the loop ring  $L_{23}(7)$ .

- (i) Study questions (i) to (vii) of problem 4 for this  $S_6$  for this  $S_5$ .
- (ii) Compare  $S$  of problem 7,  $S_1$  of problem 9,  $S_2$  of problem 8,  $S_3$  of problem 10,  $S_4$  of problem 11 with this  $S_5$ .

13. Let  $S_1 = \{\text{Collection of all subsets of the loop ring } Z_6L_5(2)\}$  be the subset non associative semiring of the loop ring  $Z_6L_5(2)$ .

Study questions (i) to (vii) of problem 4 for this  $S_1$ .

14. Let  $S_2 = \{\text{Collection of all subsets of the loop lattice } LL_5(2)\}$  be the subset non associative semiring of the loop lattice  $LL_5(2)$ .  $L$  is the lattice given in the following;

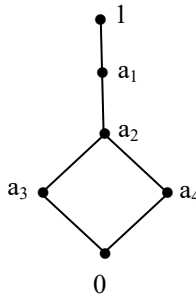

- (i) Study questions (i) to (vii) of problem 4 for this  $S_2$ .
- (ii) Compare  $S_1$  of problem (13) with this  $S_2$ .

15. Let  $S = \{\text{Collection of all subsets of the loop lattice } LG = LL_7(4)\}$  be the subset of the loop lattice  $LL_7(4)$  where  $L =$

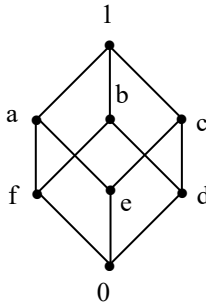

- (i) Study questions (i) to (vii) of problem 4 for this  $S$ .
  - (ii) Since  $|L| = 8$  and  $|L_7(4)| = 8$  do we have any special feature enjoyed by this  $LL_7(8)$ .
16. Give an example of a subset non associative semiring of a loop ring which satisfies Moufang identity.
17. Does there exist a subset non associative semiring  $S$  of a loop ring which satisfies the Bruck identity?
18. Does there exist a subset non associative semiring  $S$  of a loop ring which satisfies the Bol identity?
19. Does there exist a subset non associative semiring  $S$  of a loop ring  $L$  which satisfies the weak inverse property?
20. Give an example of a subset non associative semiring of a loop ring which is right alternative but not left alternative.
21. Let  $S = \{\text{Collection of all subsets of the loop ring } Z_2L_{45}(8)\}$  be the subset non associative semiring of the loop ring  $Z_2L_{45}(8)$ .
- (i) Find all subset subsemiring of  $S$ .
  - (ii) Find all subset semiring ideals of  $S$ .
  - (iii) Can  $S$  have subset idempotents?
  - (iv) Find  $o(Z_2L_{45}(8))$ .

22. Let  $S = \{\text{Collection of all subsets of the loop ring } Z_4L_{15}(14)\}$  be the subset non associative semiring of the loop ring  $Z_4L_{15}(14)$ .

- (i) Study questions (i) to (iv) of problem 21 for this  $S$ .
- (ii) Does some of the elements of  $S$  satisfy any of these special identities?

23. Let  $S_1 = \{\text{Collection of all subsets of the loop lattice } LL_{15}(14) \text{ where } L =$

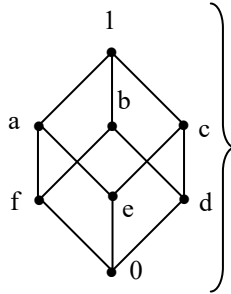

be the subset non associative semiring of the loop lattice  $LL_{15}(14)$ .

- (i) Study questions (i) to (iv) of problem 21 for this  $S_1$ .
- (ii) Compare  $S$  of problem 22 with this  $S_1$ .

24. Let  $S_2 = \{\text{Collection of all subsets of the loop lattice } LL_{15}(14)\}$  be the subset non associative semiring of the loop lattice  $LL_{15}(14)$ , where  $L =$

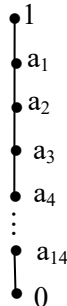

- (i) Study questions (i) to (iv) of problem 21 for this  $S_2$ .
  - (ii) Compare  $S$  of problem 22 and  $S_1$  of problem 23 with this  $S_2$ .
25. Let  $S = \{\text{Collection of all subsets of the loop ring } ZL_{23}(4)\}$  be the subset semiring of the loop ring.
- (i) Is  $S$  commutative?
  - (ii) Prove  $S$  is non associative.
  - (iii) Can  $S$  have subset zero divisors?
  - (iv) Is  $S$  a  $S$ -subset semiring?
  - (v) Find all subset subsemirings of  $S$ .
26. Let  $S = \{\text{Collection of all subsets of the loop ring } Z_2L_{43}(4)\}$  be the subset semiring of the loop ring  $Z_2L_{43}(4)$ .
- (i) Find  $o(S)$ .
  - (ii) Is  $S$  commutative?
  - (iii) Find all subset subsemirings of  $S$ .
  - (iv) Find subset zero divisors of  $S$ .
  - (v) Can  $S$  have  $S$  subset zero divisors?
  - (vi) Prove  $S$  has subset units.
  - (vii) Can  $S$  have  $S$ -subset units?
  - (viii) Can  $S$  have subset idempotents?
  - (ix) Can  $S$  have subset idempotents which are not  $S$ -subset idempotents.
  - (x) Is  $S$  a  $S$ -subset semiring?
27. Let  $S = \{\text{Collection of all subsets of the loop ring } Z_8L_{15}(8)\}$  be the subset non associative semiring of the loop ring  $Z_8L_{15}(8)$ .

Study questions (i) to (x) of problem 26 for this  $S$ .

28. Let  $S = \{\text{Collection of all subsets of the loop ring } Z_7L_{21}(5)\}$  be the subset semiring of the loop ring  $Z_7L_{21}(5)$ .

Study questions (i) to (x) of the problem 26 for this  $S$ .

29. Let  $S = \{\text{Collection of all subsets of the loop ring } ZL_{19}(7)\}$  be the subset semiring of the loop ring  $ZL_{19}(7)$ .

- (i) Does  $S$  satisfy any of the special identities?
- (ii) Can  $S$  have subset zero divisors?
- (iii) Can  $S$  have subset subsemirings?
- (iv) Can  $S$  have  $S$ -subset idempotents?
- (v) Is  $S$  a Smarandache subset subsemiring?

30. Let  $S = \{\text{Collection of all subsets of all loop ring } Z_{17}L_{23}(4)\}$  be the subset semiring of the loop ring  $Z_{17}L_{23}(4)$ .

Study all questions (i) to (v) of the problem 29 for this  $S$ .

31. Let  $S = \{\text{Collection of all subsets of the loop ring } Z_{18}L_{25}(7)\}$  be the subset semiring of the loop ring  $Z_{18}L_{25}(7)$ .

Study questions (i) to (v) of problem 29 for this  $S$ .

32. Let  $S = \{\text{Collection of all subsets of the loop ring } LL_{19}(7)\}$  where  $L$  is the lattice

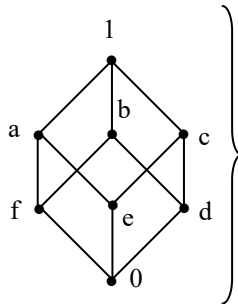

be the subset semiring of the loop lattice  $LL_{19}(7)$ .

Study questions (i) to (v) of the problem 29 for this  $S$ .

33. Let  $S = \{\text{Collection of all subsets of the loop lattice } LL_{27}(5)\}$  be the subset of the loop lattice  $LL_{27}(5)$  where  $L =$

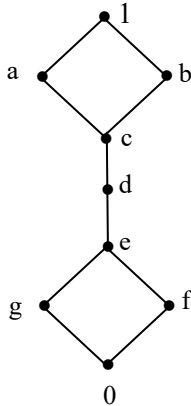

- (i) Study questions (i) to (v) of problem 29 for this  $S$ .
  - (ii) Find  $o(S)$ .
34. Give an example of a subset semiring of a loop lattice which satisfies the Bruck identity.
35. Give an example of a subset semiring of a loop ring  $ZL_n(m)$  which is right alternative but not left alternative.
36. Let  $S = \{\text{Collection of all subsets of the loop ring } Z_{18}L_7(4)\}$  be the subset semiring.
- (i) Find  $o(S)$ .
  - (ii) Does  $S$  satisfy any of the special identities?
  - (iii) Find the number of subset subsemirings of  $S$ .
  - (iv) Is  $S$  a Smarandache subset semiring?
  - (v) Can  $S$  have subset ideals?
  - (vi) Enumerate some special features enjoyed by  $S$ .
37. Let  $S = \{\text{Collection of all subsets of the loop ring } Z_7L_{25}(7)\}$  be the subset semiring of the loop ring  $Z_7L_{25}(7)$ .

Study questions (i) to (vi) of problem 36 for this  $S$ .

38. Let  $S = \{\text{Collection of all subsets of the loop lattice } LL_{31}(7) \text{ of the lattice } L =$

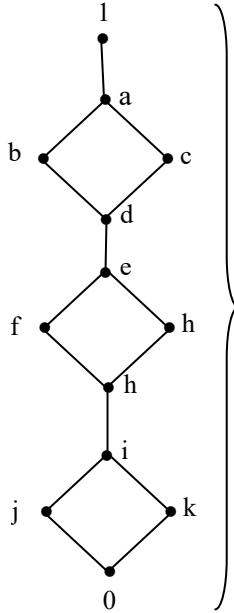

be the subset semiring of the loop lattice  $LL_{31}(7)$ .

- (i) Find  $o(S)$ .
  - (ii) Find all subset subsemirings of  $S$ .
  - (iii) Find all subset ideals of  $S$ .
  - (iv) Can  $S$  satisfy any of the special identities?
  - (v) Is  $S$  a Smarandache subset semiring?
  - (vi) Can  $S$  have Smarandache subset zero divisors?
39. Let  $S = \{\text{Collection of all subsets of the loop ring } Z_{12}L_{19}(3)\}$  be the subset semiring of the loop ring  $Z_{12}L_{19}(3)$ .

Study questions (i) to (vi) of problem 38 for this  $S$ .



40. Let  $S = \{\text{Collection of all subsets of the loop semiring } (Z^+ \cup \{0\}) L_{27}(5)\}$  be the subset semiring of the loop semiring  $(Z^+ \cup \{0\}) L_{27}(5)$ .

Study questions (i) to (vi) of problem 38 for this  $S$ .

If  $Z^+ \cup \{0\}$  is replaced by  $Z$  in this problem compare both the subset semirings.

41. Let  $S = \{\text{Collection of all subsets of the loop ring } Z_2L_{25}(4)\}$  be the subset semiring.

- (i) Find  $o(S)$ .
- (ii) Can  $S$  have subset right quasi regular elements which are not subset left quasi regular elements?
- (iii) Can  $S$  have subset quasi regular elements?
- (iv) Find all subset quasi regular elements of  $L$ .

42. Let  $S = \{\text{Collection of all subsets of the loop ring } Z_{19}L_{19}(8)\}$  be the subset semiring.

Study questions (i) to (iv) of problem 41 for this  $S$ .

43. Let  $S = \{\text{Collection of all subsets of the loop ring } Z_5L_9(8)\}$  be the subset semiring of the loop ring  $Z_5L_9(8)$ .

- (i) Find all subset quasi regular elements of  $S$ .
- (ii) Study questions (i) to (iv) of problem 41 for this  $S$ .

44. Let  $S = \{\text{Collection of all subsets of the loop lattice } LL_{21}(11)\}$  be the subset semiring of the loop lattice  $LL_{21}(11)$ , where  $L$  is the lattice given in the following:

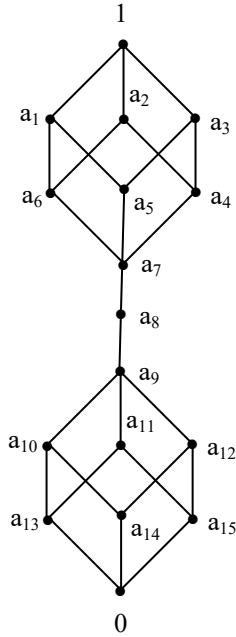

Study questions (i) to (iv) of problem 41 for this S.

45. Let  $S = \{\text{Collection of all subsets of the loop lattice } LL_7(6) \text{ where } L =$



be the subset semiring of the loop lattice  $LL_7(6)$ .

Study questions (i) to (iv) of problem 41 for this S.

46. Does there exist a subset semiring  $S$  of a loop ring in which every element of  $S$  is subset right quasi regular?
47. Does there exist a subset semiring  $S$  of a loop ring in which no element is subset right quasi regular?
48. Does there exist a subset semiring  $S$  of a loop ring in which every element is subset quasi regular?  
Can  $S$  be non commutative?
49. Let  $S = \{\text{Collection of all subsets of the loop ring } (Z^+ \cup \{0\}) L_{13}(4)\}$  be the subset semiring of the loop ring  $(Z^+ \cup \{0\}) L_{13}(4)$ .
- Can  $S$  have subset right quasi regular elements which are not subset left quasi regular in  $S$ .
  - Study questions (i) to (iv) of problem 41 for this  $S$ .
50. Let  $S = \{\text{Collection of all subsets of the loop ring } QL_{45}(14)\}$  be the subset semiring of the loop ring  $QL_{45}(14)$ .
- Can  $S$  have subset left quasi regular elements?
  - Can  $S$  have subset quasi regular elements?
  - Find some special features enjoyed by  $S$ .
  - Is it possible for  $S$  to contain a subset quasi regular elements?
  - Find all subset quasi regular elements of  $S$ .
51. What is the algebraic structure enjoyed by subset quasi regular elements of a subset semiring  $S$  of a loop ring?
52. Characterize those subset quasi regular elements of a subset semiring of a loop ring which enjoys a nice algebraic structure.
53. Is it possible for a subset semiring of a finite loop ring to be such that  $S$  has no subset quasi regular elements and no subset right or subset left quasi regular elements.

54. Does there exist a subset semiring of a loop ring which is not a Smarandache subset semiring?
55. Does there exist a subset semiring  $S$  of a loop ring which are not subset zero divisors?
56. Does there exist a subset semiring  $S$  which has no subset  $S$ -idempotents?
57. Study the properties enjoyed by Jacobson radical of a subset semiring  $S$  of a loop ring.
58. Does there exist a subset semiring which is semisimple?
59. Characterize those subset semirings  $S$  of a loop ring in which  $J(S) = \{0\}$ .
60. Characterize those subset semirings of loop rings in which  $J(S) \neq \{0\}$ .
61. Obtain some special features of  $S$  of a subset loop ring  $RL$ .  
Can one say  $J(RL) \neq \{0\}$  imply  $J(S) \neq \{0\}$ ?
62. Is it possible to have  $J(RL) = \{0\}$  but  $J(S) \neq \{0\}$ ?
63. Define and describe the concept of augmentation subset ideal of a subset semiring  $S$  of a loop ring.
64. Let  $S = \{\text{Collection of all subsets of the loop ring } Z_2L_7(3)\}$  be the subset loop ring of  $Z_2L_7(3)$ .
  - (i) Find  $o(W(S))$ .
  - (ii) Prove  $o(W(S)) \neq \{0\}$ .
  - (iii) Does  $W(S)$  enjoy any other algebraic structure?
  - (iv) Find  $J(S)$ .
  - (v) Is  $J(S) \subseteq W(S)$  or  $o(W(S)) \subseteq J(S)$ ?
  - (vi) Find  $o(S)$ .

65. Let  $S = \{\text{Collection of all subsets of the loop ring } Z_3L_{19}(3)\}$  be the subset semiring of the loop ring  $Z_3L_{19}(3)$ .

Study questions (i) to (vi) of problem 64 for this S.

66. Let  $S = \{\text{Collection of all subsets of the loop ring } Z_6L_{23}(4)\}$  be the subset semiring of the loop ring  $Z_6L_{23}(4)$ .

- (i) Study questions (i) to (vi) of problem 64 for this S.
- (ii) If  $L_{23}(4)$  is replaced by  $L_{23}(7)$  will the answers to questions (i) to (vi) differ?
- (iii) Will all the answers to questions (i) to (vi) be the same for all  $L_{23}(m) \in L_{23}$ ,  $m = 2, \dots, 22$ ?

67. If  $Z_6$  is replaced in problem 66 by  $Z_7$ . Study all the questions (i) to (iii) of problem (64).

- (i) When will  $W(S)$  have larger cardinality in case of S in problem 66 or in case of S in problem 67.

68. Let  $S = \{\text{Collection of all subsets of the loop ring } C(Z_3)L_7(4)\}$  be the subset semiring of the complex modulo integer loop ring  $C(Z_3) L_7(4)$ .

- (i) Find  $o(S)$ .
- (ii) Find  $W(S)$  and  $o(W(S))$ .
- (iii) Find  $J(S)$ .
- (iv) Will  $o(J(S)) = n \neq 0$ ?

69. Let  $S = \{\text{Collection of all subsets of the loop ring } C(Z_{10})L_9(8)\}$  be the subset semiring of the complex modulo integer loop ring  $C(Z_{10}) L_9(8)$ .

Study questions (i) to (iv) of problem 68 for this S.

70. Let  $S_1 = \{\text{Collection of all subsets of the loop ring } C(Z_6)(g) L_{13}(7); g^2 = -g\}$  be the subset semiring of the loop ring  $C(Z_6)(g) L_{13}(7)$ .

- (i) Study questions (i) to (iv) of problem 68 for this S.
  - (ii) If  $C(Z_6)(g)$  is replaced in  $S_1$  by  $Z_6$ . Study questions (i) to (iv) of problem 68 for this  $S_1$ .
  - (iii) If  $C(Z_6)(g)$  in  $S_1$  is replaced by  $Z_6(g)$ . Study questions (i) to (iv) of problem 68 for that S.
  - (iv) If in S,  $C(Z_6)(g)$  is replaced by  $C(Z_6)$  study questions (i) to (iv) of problem 68 for that S.
71. Find some special and interesting features enjoyed by the usual topological space of subset non associative semirings.
72. Give an example of a usual topological space of subset semiring of finite order.
73. Can we ever have a usual topological space subset semiring of a loop ring of order 15? Justify your answer.
74. Let  $S = \{\text{Collection of all subsets of the loop ring } Z_2L_{17}(3)\}$  be the subset non associative semiring of the loop ring  $Z_2L_{17}(3)$ .
- (i) Find  $o(S)$ .
  - (ii)  $T = \{S \cup \{\phi\}, \cup, \cap\}$  be the usual topological space of the subset semiring S. Find usual subset topological subspaces of T.
  - (iii) Is T a discrete subset topological space?
75. Let  $S = \{\text{Collection of all subsets of the loop ring } Z_3L_7(4)\}$  be the subset semiring of the loop ring  $Z_3L_7(4)$ .
- Study questions (i) to (iii) of problem 74 for this S.
76. Let  $S_1 = \{\text{Collection of all subsets of the loop semiring } LL_7(4)\}$  be the subset semiring of  $LL_7(4)$  where  $L =$

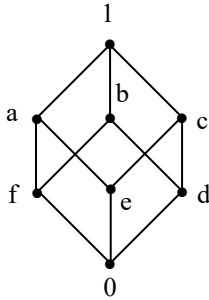

Study questions (i) to (iii) of problem 74 for this  $S$ . Compare  $S$  in problem 75 with  $S_1$  in problem 76.

77. Let  $S = \{\text{Collection of all subsets of the loop semiring } (Z^+ \cup \{0\}) L_{19}(3)\}$  be the subset semiring of the loop semiring  $(Z^+ \cup \{0\}) L_{19}(3)$ .

Study questions (i) to (iii) of problem 74 for this  $S$ .

78. Let  $S_1 = \{\text{Collection of all subsets of the loop ring } ZL_{19}(3)\}$  be the subset semiring of the loop ring  $ZL_{19}(3)$ .

- (i) Study questions (i) to (iii) of problem 74 for  $S_1$ .
- (ii) Compare  $S$  in problem 77 with  $S_1$  in this problem.
- (iii) Prove  $S$  is a subset semiring usual topological subspace of  $S_1$ .

79. Let  $S = \{\text{Collection of all subsets of the loop ring } Z_7(9)L_7(3), g^2 = 0\}$  be the subset semiring of the loop ring  $Z_7(9)L_7(3)$ .

- (i) Study questions (i) to (iii) of problem 74 for this  $S$ .
- (ii) Find all usual subset topological subspaces of  $S$  of this subset semiring.
- (iii) How many such usual subset topological subspaces of  $T = \{S \cup \{\emptyset\}, \cup, \cap\}$  exist?
- (iv) Is  $T$  a metric space? (Can a  $T$  be made into a subset topological space with a metric or is  $T$  metrizable?)

- 80. Give some special properties associated with the new subset topological space of non associative subset semiring of a loop ring.
- 81. If the loop ring is replaced by a loop semiring study  $T_n$ .
- 82. Let  $S = \{\text{Collection of all subsets of the loop semiring } LL_9(8)\}$  be the subset semiring of the loop semiring  $LL_9(8)$  where  $L$  is the lattice

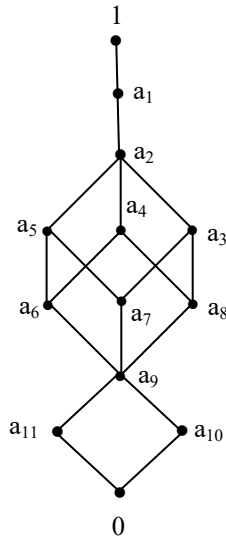

- (i) Find  $o(S)$ .
- (ii) Find the usual subset semiring topological subspaces of  $T = (S, \cup, \cap)$ .
- (iii) Find the new subset semiring topological subspaces of  $T_n = (S, \cup_n, \cap_n)$ .
- (iv) Compare  $T$  with  $T_n$ .
- (v) Find the number of subset semiring topological spaces of  $T$  and  $T_n$ .
- (vi) Which of the subset semiring topological space  $T$  or  $T_n$  has more number of subset topological subspaces?



83. Let  $S = \{\text{Collection of all subsets of the loop semiring } LL_{11}(7) \text{ where } L \text{ is the Boolean algebra of order } 2^4\}$  be the subset semiring of  $LL_{11}(7)$ .

Study questions (i) to (vi) of problem 82 in case of this  $S$ .

84. Let  $S_1 = \{\text{Collection of all subsets of the loop ring } C(Z_{12})L_{13}(3)\}$  be the subset semiring of the complex modulo integer loop ring.

Study questions (i) to (vi) of problem 82 in case of this  $S_1$ .

85. Characteristic those subset non associative semiring of a loop ring to contain

- (i) Subset idempotents.
- (ii) S-subset idempotents.
- (iii) Subset semiidempotents.
- (iv) S-subset semiidempotents.
- (v) Subset units.
- (vi) S-subset units.

86. Let  $S_1 = \{\text{Collection of all subsets of the loop ring } Z_2LL_{13}(4)\}$  be the subset non associative semiring.

Study questions (i) to (vi) of problem 85 for this  $S_1$ .

87. Let  $S_2 = \{\text{Collection of all subsets of the loop ring } QL_{19}(7)\}$  be the subset non associative semiring of the loop ring  $QL_{19}(7)$ .

Study questions (i) to (vi) of problem 85 for this  $S_2$ .

88. Let  $S_3 = \{\text{Collection of all subsets of the loop semiring } LL_{23}(7) \text{ where } L = C_8 \text{ be the chain lattice}\}$  be the subset non associative semiring of the loop semiring  $LL_{23}(7)$ .

Study questions (i) to (vi) of problem 85 for this  $S_3$ .

89. Characteristic those subset non associative semirings  $S$  which has subset semiidempotents and Smarandache subset semiidempotents.
90. Does there exists a subset non associative semiring of a loop ring which has no subset semiidempotents?
91. Does there exist a subset non associative semiring of a loop ring which has subset semiidempotent but none of them are Smarandache subset semiidempotents?
92. Characteristic those subset non associative semirings of a loop ring which has normal subset subsemirings.
93. Let  $S = \{\text{Collection of all subsets of the loop semiring } (R^+ \cup \{0\})L_9(8)\}$  be the subset semiring of the loop semiring  $(R^+ \cup \{0\})L_9(8)$ .
- (i) Can  $S$  have subset idempotents?
  - (ii) Can  $S$  have subset zero divisors?
  - (iii) Can  $S$  have subset units?
  - (iv) Can  $S$  have subset idempotents which are not  $S$ -subset idempotents?
  - (v) Can  $S$  have subset semiidempotents which are not  $S$ -subset semiidempotents?
  - (vi) Can  $S$  have  $S$ -subset quasi regular elements?
  - (vii) Find  $J(S)$ .
  - (viii) Find  $W(S)$ .
  - (ix) Can  $S$  have subset  $S$ -ideals?
  - (x) Can  $S$  have  $S$ -weak subset zero divisor?
94. Let  $S_1 = \{\text{Collection of all subsets of the loop ring } CL_{23}(7)\}$  be the complex subset non associative semiring. Study questions (i) to (x) of problem 93 for this  $S_1$ .
95. Let  $S_2 = \{\text{Collection of all subsets of the loop ring } C(\mathbb{Z}_{10})L_{19}(3)\}$  be the subset semiring of the loop ring  $C(\mathbb{Z}_{10})L_{19}(3)$ .

Study questions (i) to (x) of problem 93 for this  $S_2$ .

96. Let  $S_3 = \{\text{Collection of all subsets of loop semiring } (\mathbb{R}^+ \cup \{0\})L_{19}(8)\}$  be the subset semiring of the loop semiring  $(\mathbb{R}^+ \cup \{0\})L_{19}(8)$ .

Study questions (i) to (x) of problem 93 for this  $S_3$ .

97. Let  $S_4 = \{\text{Collection of all subset of the loop semiring } LL_{23}(7) \text{ where } L \text{ is a lattice given as follows:}$

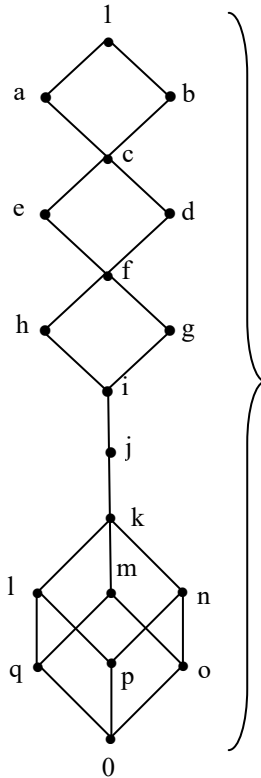

be the subset semiring of the loop semiring.

Study questions (i) to (x) of the problem 93 for this  $S_4$ .

98. Let  $S_5 = \{\text{Collection of all subsets of the loop ring } C(\mathbb{Z}_{12})(g_1, g_2) L_{19}(3) \text{ where } g_1^2 = 0, g_2^2 = g_2, g_1g_2 = g_2g_1\}$

$= 0\}$  be the subset semiring of loop ring  $C(Z_{12})$  ( $g_1, g_2$ )  $L_{19}(3)$ .

Study questions (i) to (x) of problem 93 for this  $S_5$ .

99. Let  $S = \{\text{Collection of all subsets of the loop semiring } (Z^+ \cup \{0\}) L_9(8)\}$  be the subset loop semiring of loop semiring.

- (i) Is  $S$  commutative?
- (ii) Can  $S$  have subset  $S$ -idempotents?
- (iii) Find  $S$ -subset ideals in  $S$ .
- (iv) Find subset subsemirings which are not  $S$ -subset subsemirings in  $S$ .
- (v) Is it possible for  $S$  to have subset  $S$ -zero divisors?
- (vi) If  $(L_9(8), o)$  is the principal isotope of the loop  $(L_9(8), *)$  and if  $S_{PI} = \{\text{Collection of all subsets of the loop semiring } (Z^+ \cup \{0\}) (L_9(8), 0)\}$  be the subset loop semiring of the loop semiring  $(Z^+ \cup \{0\})(L_9(8), o)$ . Compare  $S$  and  $S_{PI}$ .
- (vii) Study questions (i) to (v) for this  $S_{PI}$  also.

100. Let  $S_1 = \{\text{Collection of all subsets of the loop semiring } = \text{PL of the loop } L_7(4) \text{ and the semiring } P =$

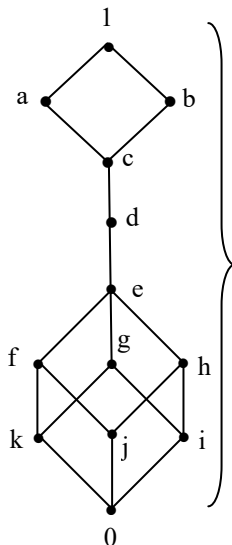

be the subset loop semiring of  $PL_7(4)$ .

- (i) Study questions (i) to (vii) of problem 99 in case of  $S_1$ .
- (ii) Find  $o(S_1)$ .

101. Let  $S_2 = \{\text{collection of all subsets of the loop semiring } ML_{27}(11)\}$  be the subset loop semiring of the loop semiring  $ML_{27}(11)$  where  $M =$

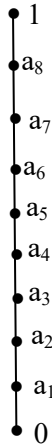

- (a) Study questions (i) to (vii) of problem 99 for this  $S_2$ .
- (b) Compare  $S$  of problem 99 with this  $S_2$ .

102. Let  $S_3 = \{\text{Collection of all subsets of the loop semiring } BL_7(6)\}$  be the subset loop semiring of the loop semiring  $BL_7(6)$  where  $B$  is the Boolean algebra which is as follows:

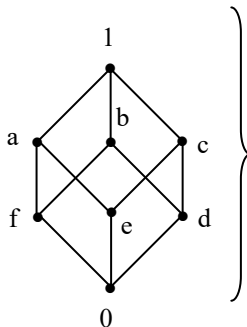

- (a) Study questions (i) to (vii) of problem 99 for this  $S_3$ .
  - (b) Compare  $S_1$  of problem 100 and  $S$  of problem 99 with this  $S_3$ .
103. Study problem 102 where  $BL_7(6)$  is replaced by  $B_1L_{15}(8)$  where  $B_1$  is a Boolean algebra of order 16.
104. If  $B_iL_n(m)$  is used in  $S_3$  of problem (102) instead of  $BL_7(6)$ .  
Study when
- (i)  $|B_i| = |L_n(m)|$ .
  - (ii)  $|B_i| / |L_n(m)|$ .
  - (iii)  $|L_n(m)| / |B_i|$ .
  - (iv)  $[|L_n(m)|, |B_i|] = 1$ .
  - (v)  $[|L_n(m)|, |B_i|] = d, d \neq 1$ .
105. Let  $S = \{\text{Collection of all subsets of the loop ring } Z_{12}L_{11}(8)\}$  be the subset loop semiring of the loop ring  $Z_{12}L_{11}(8)$ .  
  
Study questions (i) to (vii) of problem 99 for this  $S$ .
106. Let  $S_1 = \{\text{Collection of all subsets of the loop ring } Z_{19}L_{15}(8)\}$  be the subset loop semiring of the loop ring  $Z_{19}L_{15}(8)$ .
- (i) Study questions (i) to (vii) of problem 99 for this  $S_1$ .
  - (ii) Compare  $S$  of problem 105 with this  $S_1$ .
107. Let  $S_2 = \{\text{Collection of all subsets of the loop ring } Z_6L_{17}(8)\}$  be the subset loop semiring of the loop ring  $Z_6L_{17}(8)$ .
- (i) Study questions (i) to (vii) of problem 99 for this  $S_2$ .
  - (ii) Compare  $S_2$  with  $S$  of problem 105 and  $S_1$  of problem 106.

108. Let  $S_3 = \{\text{Collection of all subsets of the loop ring } Z_{18}L_5(3)\}$  be the subset loop semiring of the loop ring  $Z_{18}L_5(3)$ .
- Study questions (i) to (vii) of problem 99 for this  $S_3$ .
  - Compare  $S_3$  with  $S_2$  of problem 107,  $S_1$  of problem 106 and  $S$  of problem 105.
109. Let  $S_4 = \{\text{Collection of all subsets of the loop ring } Z_{26}L_{25}(7)\}$  be the subset loop semiring of the loop ring  $Z_{26}L_{25}(7)$ .
- Study questions (i) to (vii) of problem 99 for this  $S_4$ .
  - Compare  $S_4$  of this problem with  $S_3$  of problem 108,  $S_2$  of problem 107,  $S_1$  of problem 106 and  $S$  of problem 105.
110. Let  $S = \{\text{Collection of all subsets of the loop ring } Z_tL_n(m)\}$  the loop ring  $Z_tL_n(m)$ .
- Study  $S$  if  $|Z_t| = |L_n(m)|$ .
  - What happens in  $S$  if  $|Z_t| / |L_n(m)|$  ?
  - Analyse  $S$  if  $|L_n(m)| / |Z_t|$ .
  - Study  $S$  if  $[|Z_t|, |L_n(m)|] = 1$ .
  - Study  $S$  if  $[|Z_t|, |L_n(m)|] = d$ ,  $d \neq 1$ ,  $d \neq |Z_t|$  and  $d \neq |L_n(m)|$ .
111. Let  $S = \{\text{Collection of all subsets of the loop ring } Z_5(L_5(2) \times L_5(3))\}$  be the subset loop semiring of the loop ring  $Z_5(L_5(2) \times L_5(3))$ .
- Find  $o(S)$ .
  - Study questions of (i) to (vii) problem of 99 for this  $S$ .
112. Let  $S = \{\text{Collection of all subsets of the loop ring } (Z_6 \times Z_7) (L_{11}(9) \times L_{13}(2))\}$  be the subset loop semiring of the loop ring  $(Z_6 \times Z_7) (L_{11}(9) \times L_{13}(2))$ .

- (i) Study questions (i) to (vii) of problem 99 for this S.
  - (ii) Find  $o(S)$ .
113. Let  $S = \{\text{Collection of all subsets of the loop ring } ZL_{21}(11)\}$  be the subset loop semiring of the loop ring  $ZL_{21}(11)$ .
- (i) Study questions (i) to (vii) of problem 99 for this S.
  - (ii) Find the collection of all subset zero divisors and S-subset zero divisors in S.
114. Let  $S = \{\text{Collection of all subsets of the loop ring } C(Z_{12})L_{13}(9)\}$  be the subset loop semiring of the loop ring  $C(Z_{12})L_{13}(9)$ .
- (i) Study questions (i) to (vii) of problem 99 for this S.
  - (ii) Find  $o(S)$ .
115. Let  $S = \{\text{Collection of all subsets of the loop ring } (C(Z_7)(g))(L_{15}(14)) \text{ with } g^2 = 0\}$  be the subset loop semiring of the loop ring  $(C(Z_7)(g))L_{15}(14)$ .
- (i) Find  $o(S)$ .
  - (ii) Study questions (i) to (vii) of problem 99 for this S.
  - (iii) Find all subset zero divisors and S-zero divisors.
116. Let  $S = \{\text{Collection of all subsets of the loop ring } [Z(g_1, g_2, g_3)]L_{45}(23)\}$  be the subset loop semiring of the loop ring  $(Z(g_1, g_2, g_3))L_{45}(23)$  where  $g_1^2 = 0$ ,  $g_2^2 = g_2$  and  $g_3^2 = -g_3$ ,  $g_i g_j = g_j g_i = 0$  if  $i \neq j$ ,  $1 \leq i, j \leq 3$ .
- (i) Study questions (i) to (vii) of problem 99 for this S.
  - (ii) Find all subset zero divisors, subset idempotents and subset units of S.
117. Let  $S = \{\text{Collection of all subsets of the loop ring } [C(Z_{20})(g_1, g_2, g_3)]L_{23}(9)\}$  be the subset loop semiring of



loop ring  $[C(\mathbb{Z}_{20}) (g_1, g_2, g_3)] L_{23}(9)$  where  $g_1^2 = 0$ ,  $g_2^2 = g_2$  and  $g_3^2 = -g_3$ ,  $g_i g_j = g_j g_i = 0$  if  $i \neq j$ ,  $1 \leq i, j \leq 3$ .

- (i) Study questions (i) to (vii) of problem 99 for this S.
- (ii) Find  $o(S)$ .
- (iii) Find all subset zero divisors, subset units, subset idempotents and their Smarandache analogue.

118. Let  $S = \{\text{Collection of all subsets of the loop ring } [Z_8(g_1, g_2, g_3)] L_7(5)\}$  be the subset loop semiring of the loop ring  $[Z_8(g_1, g_2, g_3)] L_7(5)$  where  $g_1^2 = 0$ ,  $g_2^2 = g_2$  and  $g_3^2 = -g_3$ ,  $g_i g_j = g_j g_i = 0$  if  $i \neq j$ ,  $1 \leq i, j \leq 3$ .

- (i) Study questions (i) to (vii) of problem 99 for this S.
- (ii) Find  $o(S)$ .
- (iii) Find all subset S-zero divisors, S- subset units and subset S-idempotents of S.

119. Let  $S = \{\text{Collection of all subsets of the loop ring } [C(\mathbb{Z}_9) \times Z_8(g_1, g_2)] L_{19}(8)\}$  be the subset loop semiring of the loop ring  $[C(\mathbb{Z}_9) \times Z_8(g_1, g_2)] L_{19}(8)$ ; where  $g_1^2 = 0$ ,  $g_2^2 = g_2$ ,  $g_i g_j = 0$  if  $i \neq j$ ,  $1 \leq i, j \leq 2$ .

- (i) Study questions (i) to (vii) of problem 99 for this S.
- (ii) Find  $o(S)$ .
- (iii) Find subset zero divisors, subset S-zero divisors, subset units, subset S-units, subset idempotents subset S-idempotents.

120. Let  $S = \{\text{Collection of all subsets of the loop ring } (C(g_1, g_2, g_3)) L_{19}(8)\}$  be the subset loop semiring of the loop ring  $C(g_1, g_2, g_3) (L_{19}(8))$ .

- (i) Study questions (i) to (vii) of problem 99 for this S.
- (ii) Enumerate all subset zero divisors and subset S-units of S.

121. Let  $S = \{\text{Collection of all subsets of the loop ring } M = [\mathbb{R} \times \mathbb{Z}(g)] [(L_9(8) \times L_{17}(8) \times L_{29}(5))]\}$  be the subset loop semiring of the loop ring  $M$ .

- (i) Study questions (i) to (vii) of problem 99 for this  $S$ .
- (ii) Show  $S$  has infinitely many subset zero divisors.
- (iii) Can  $S$  have infinitely many subset  $S$ -zero divisors?
- (iv) Can  $S$  have infinitely many subset idempotents and  $S$ -subset idempotents?
- (v) Study the subset units and  $S$ -subset units of  $S$ .
- (vi) Prove  $S$  has infinitely many subset loop subsemirings.
- (vii) Can  $S$  have infinitely many subset loop semiring ideals? Justify.

122. Let  $S = \{\text{Collection of all subsets of the loop ring } N = (\mathbb{Z}_8 \times C(\mathbb{Z}_{12}) \times C(\mathbb{Z}_9) (g_1, g_2)) [(L_9(8) \times L_{13}(6) \times L_{15}(8))]\}$  be the subset loop semiring of the loop ring  $N$  ( $g_1^2 = 0, g_2^2 = g_2, g_1 = g_2 = g_2, g_1 = 0$ ).

- (i) Study questions (i) to (vii) of problem 99 for this  $S$ .
- (ii) Find  $o(S)$ .
- (iii) Find all subset zero divisors and  $S$ -subset zero divisors of  $S$ .
- (iv) Find all subset units and  $S$ -subset units of  $S$ .
- (v) Find all subset idempotents and  $S$ -subset idempotents of  $S$ .
- (vi) Find all subset loop ideals of  $S$ .
- (vii) Find all subset loop  $S$ -ideals of  $S$ .
- (viii) Find all subset loop subsemirings of  $S$ .
- (ix) Find all subset loop  $S$ -subsemirings of  $S$ .
- (x) Find  $S_{PI} = \{\text{Collection of all subsets of the principal isotope loop rings } N_{PI} = (\mathbb{Z}_8 \times C(\mathbb{Z}_{12}) \times C(\mathbb{Z}_9) \times (g_1, g_2)) [(L_9(8), o) \times (L_{13}(6), o) \times (L_{15}(8), o)]\}$  be the subset loop semiring  $((L_n(m), o)$  is the principal isotope loop of the loop  $(L_n(m), +)$ ).

Study all questions (i) to (x) for this  $S_{PI}$ .

123. Characterize those subset loop semirings of a loop ring which has subset semiidempotents?
124. Characterize those subset loop semirings which has no subset semiidempotents.
125. Let  $S = \{\text{Collection of all subsets of the loop ring } QL_{29}(3)\}$  be the subset loop semiring of the loop ring  $QL_{29}(3)$ .
- (i) Does  $S$  contain subset semiidempotents?
  - (ii) Can  $S$  have Smarandache subset semi idempotents?
126. Let  $S = \{\text{Collection of all subsets of the loop ring } Z_{12}L_{11}(4)\}$  be the subset loop semiring of the loop ring  $Z_{12}L_{11}(4)$ .
- (i) Can  $S$  have subset semiidempotents?
  - (ii) Can  $S$  have  $S$ -subset semiidempotents?
127. Does there exist a subset loop semiring which has no subset semiidempotents?
128. Does there exist a subset loop semiring of a loop ring which has subset semiidempotents but has no  $S$ -subset semi idempotents?
129. Does there exist a subset loop semiring of the loop ring  $RL_n(m)$  where  $R$  is a field or ring contain both subset semiidempotents as well as  $S$ -subset semiidempotents?
130. Does there exist a subset semiidempotent in subset loop semiring  $S$  of the loop semiring  $PL$  where  $P$  is a semiring of a semifield and  $L$  a loop?  
(Here in case of loop semirings we replace  $\alpha^2 - \alpha$  by  $\alpha^2 + \alpha$ ).

131. Let  $S = \{\text{Collection of all subsets of the loop semiring } M = (Z^+ \cup \{0\}) L_{23}(8)\}$  be the subset loop semiring of the loop semiring  $M$ .

- (i) Can  $S$  have subset semi idempotents?
- (ii) Can  $S$  have subset  $S$ -semiidempotents?
- (iii) Can  $S$  have subset semiidempotents which are not  $S$ -subset semiidempotents?
- (iv) Find the total number of subset semiidempotents in  $S$ .

132. Let  $S = \{\text{Collection of all subsets of the loop semiring } P = (Q^+ \cup \{0\}) L_{25}(8)\}$  be the subset loop semiring of the loop semiring  $P$ .

Study questions (i) to (iv) of problem 131 for this  $S$ .

133. Let  $S = \{\text{Collection of all subsets of the loop semiring } M = PL_{15}(8)\}$  be the subset loop semiring of the loop semiring  $M$  where  $P =$

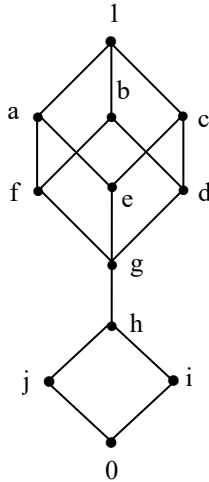

Study questions (i) to (iv) of problem 131 for this  $S$ .

134. Let  $S = \{\text{Collection of all subsets of the loop semiring } RL_{21}(11) \text{ where } R \text{ is a chain lattice which is as follows:}$

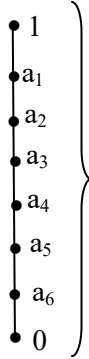

be the subset loop semiring of the loop semiring  $RL_{21}(11)$ .

Study questions (i) to (iv) of problem 131 for this  $S$ .

135. Let  $S = \{\text{Collection of all subsets of the loop semiring } (L_1 \times L_2) (L_9(8) \times L_{21}(20)) \text{ be the subset loop semiring of the loop semiring } (L_1 \times L_2) (L_9(8) \times L_{21}(20)).$

Study questions (i) to (iv) of problem 131 for this  $S$ .

136. Distinguish between the subset semiidempotents of a subset semiring built over a loop semiring and that of the one built over a loop ring.

137. Let  $S = \{\text{Collection of all subsets of the loop ring } Z_9L_7(4)\}$  be the subset loop semiring.

- (i) Find  $o(S)$ .
- (ii) Find the subset topological space  $T$  of  $S$  where  $T = (S', \cup, \cap)$ .
- (iii) Find a new topological subset space of the loop semiring  $T_n = (S, \cup_n, \cap_n)$ .

(iv) Prove in  $T_n$  the operations

- (a)  $\cap_n$  is not associative.
- (b)  $\cap_n$  and  $\cup_n$  are not subset idempotent.
- (c)  $T_n$  is a new type of topological space from the usual subset topological spaces.

138. Let  $S = \{\text{Collection of all subsets of the loop ring } ZL_{25}(7)\}$  be the subset loop ring of the loop ring  $ZL_{25}(7)$ .

Study questions (ii) to (iv) of problem 137 for this  $S$ .

139. Let  $S_1 = \{\text{Collection of all subsets of the loop semiring } Z^+ \cup \{0\} L_{25}(7)\}$  be the subset loop semiring of the loop semiring  $Z^+ \cup \{0\} L_{25}(7)$ .

- (i) Study questions (ii) to (iv) for this  $S_1$  of problem 137.
- (ii) Compare  $S$  of problem (138) with  $S_1$  of problem 139.

140. Let  $S$  be a subset loop semiring. Study all the special features enjoyed by both the subset topological spaces of loop semiring.

$$T = (S', \cup, \cap) \text{ and } T_n = (S', \cup_n, \cap_n).$$

141. What are the distinct features of  $T_n = (S, \cup_n, \cap_n)$  which is different from any topological space?

142. Let  $S = \{\text{Collection of all subsets of the loop semiring } B = LL_{23}(7)\}$  be the subset topological space of the subset loop semiring where  $L$  is a lattice given by

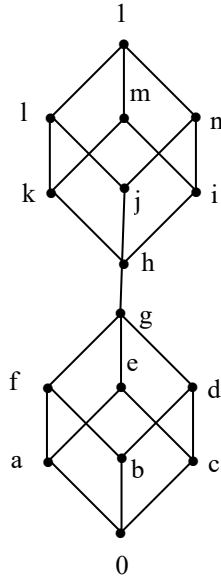

Study questions (i) to (iv) of problem 137 in case of this S.

143. Let  $S = \{\text{Collection of all subsets of the loop semiring } M = LL_{19}(8)\}$  be the subset loop semiring of the loop semiring where L is a chain lattice given by



Study questions (i) to (iv) of problem 137 for this S.

144. Let  $S = \{\text{Collection of all subsets of the loop semiring } N = (L_1 \times L_2) (L_7(6) \times L_{25}(9))\}$  be the subset loop semiring of the loop semiring  $N$ , where  $L_1 = \{\text{A Boolean algebra of order 16}\}$  and  $L_2$  is a lattice given by

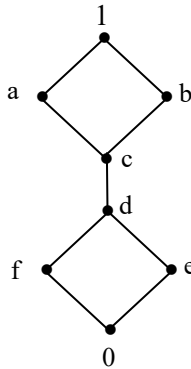

- (i) Study questions (i) to (iv) of problem 137 in case of this  $S$ .
- (ii) If  $P_1 = (L_1 \times L_2) L_7(6)$  and  $P_2 = (L_1 \times L_2) L_{25}(9)$  and  $S_1$  and  $S_2$  the subset loop semirings of the loop semirings  $P_1$  and  $P_2$  respectively. Compare  $S$  with  $S_1$  and  $S_2$ .
- (iii) For this  $S_1$  and  $S_2$  study questions (i) to (iv) of problem 137.
- (iv) Let  $B_1 = L_1 (L_7(6) \times L_{25}(9))$  and  $B_2 = L_2 (L_7(6) \times L_{25}(9))$  be any two loop semirings. Suppose  $M_1$  and  $M_2$  are the subset loop semirings of the loop semiring  $B_1$  and  $B_2$  respectively.
  - (a) Compare  $S$  with  $M_1$  and  $M_2$ .
  - (b) Compare  $S_1$  and  $S_2$  with  $M_1$  and  $M_2$ .
  - (c) Study questions (i) to (iv) of problem 137 for this  $M_1$  and  $M_2$ .
- (v) Suppose  $N_1 = L_1 L_7(6)$  and  $N_2 = L_2 L_{25}(9)$  be two loop semiring. Suppose  $W_1$  and  $W_2$  be the subset loop semirings of the loop semirings  $N_1$  and  $N_2$  respectively.



- (a) Study questions (i) to (iv) of problem 137 for  $W_1$  and  $W_2$ .
- (b) Compare  $S$  with  $W_1$  and  $W_2$ .
- (c) Compare  $S_1$  and  $S_2$  with  $W_1$  and  $W_2$ .
- (d) Compare  $M_1$  and  $M_2$  with  $W_1$  and  $W_2$ .

145. Let  $S = \{\text{Collection of all subsets of the loop ring } Z_9L_{29}(7)\}$  be the subset loop semiring of the loop ring  $Z_9L_{29}(7)$ .  $T = \{S', \cup, \cap\}$  be the subset topological loop semiring space.  $T_n = \{S, \cup_n, \cap_n\}$  be the subset new topological loop semiring space.

- (i) Find  $o(T)$ .
- (ii) Find  $o(T_n)$ .
- (iii) Find all subset topological loop semiring subspaces of  $T$ .
- (iv) Find all subset new topological loop semiring subspaces of  $T_n$ .
- (v) Show  $T_n$  is a non associative new topological space.

146. Let  $S = \{\text{Collection of all subsets of the loop ring } LL_{29}(3)\}$  be the subset loop semiring of  $LL_{29}(3)$  where  $L =$

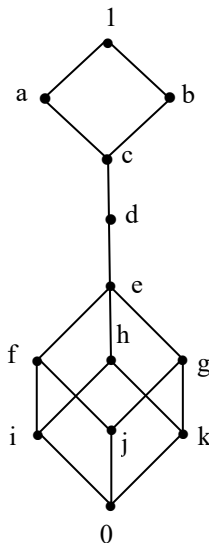

Study questions (i) to (v) of problem 145 for this S.

147. Let  $S = \{\text{Collection of all subsets of the loop ring } M = C(\mathbb{Z}_{25}) \langle g_1, g_2, g_3 \rangle L_{25}(7)\}$  be the subset loop semiring of the loop ring  $M$ .

Study questions (i) to (v) of problem 145 for this S.

148. Let  $S = \{\text{Collection of all subsets of the loop ring } N = C(\mathbb{Z}_{12}) L_{27}(8)\}$  be the subset loop semiring of the  $N$ .

Study questions (i) to (v) of problem 145 for this S.

149. Let  $S = \{\text{Collection of all subsets of the neutrosophic loop ring } N = \langle \mathbb{Z}_{40} \cup I \rangle L_{41}(8)\}$  be the subset neutrosophic loop semiring of the neutrosophic loop ring  $N$ .

Study questions (i) to (v) of problem 145 for this S.

150. Let  $S = \{\text{Collection of all subsets of the neutrosophic loop ring } P = \langle \mathbb{Z} \cup I \rangle L_{29}(8)\}$  be the subset neutrosophic loop semiring of the neutrosophic loop semiring  $P$ .

- (i) Find  $o(S)$ .
- (ii) Find all subset neutrosophic loop subsemirings of  $S$ .
- (iii) Find all subset loop subsemirings of  $S$  which are not neutrosophic.
- (iv) Find all subset ideals of  $S$  and show they must be neutrosophic.
- (v) Find all subset zero divisors of  $S$ .
- (vi) Find subset idempotents of  $S$ .
- (vii) Study questions (i) to (v) of problem 145 for this S.

151. Let  $S = \{\text{Collection of all subsets of the neutrosophic loop ring } M = \langle \mathbb{Z}_{12} \cup I \rangle L_{43}(8)\}$  be the subset neutrosophic loop semiring of the loop ring  $M$ .

(i) Study questions (i) to (vii) of problem 150 for this S.

152. Let  $S = \{\text{Collection of all subsets of the neutrosophic loop semiring } M = (L \times \langle \mathbb{Z}_{10} \cup I \rangle) \times \langle \mathbb{Z}_3 \cup I \rangle L_{21}(11)\}$  be

the subset neutrosophic loop semiring of the neutrosophic loop semiring  $M$  where  $L =$

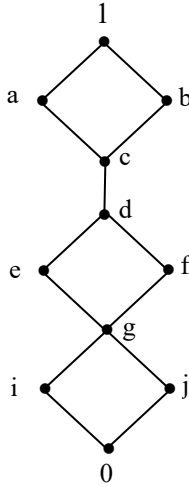

Study questions (i) to (vii) of the problem 150 for this  $S$ .

153. Let  $S = \{\text{Collection of all subsets of the neutrosophic loop semiring } P = (\langle \mathbb{Z}^+ \cup I \rangle \cup \{0\}) L_{81}(11)\}$  be the subset neutrosophic loop semiring of  $P$ .

Study questions (i) to (vii) of the problem (150) for this  $S$ .

154. Let  $S = \{\text{Collection of all subsets of the neutrosophic loop ring } N = C(\langle \mathbb{Z}_{20} \cup I \rangle) L_{31}(18)\}$  be the subset neutrosophic loop semiring of the loop ring  $N$ .

Study questions (i) to (vii) of the problem 150 for this  $S$ .

155. Let  $S = \{\text{Collection of all subsets of the neutrosophic loop ring } P = (\langle \mathbb{Z}_{12} \cup I \rangle \times \langle \mathbb{Z}_{19} \cup I \rangle) (L_9(8) \times L_{29}(8))\}$  the subset neutrosophic loop semiring of the neutrosophic loop ring.

Study questions (i) to (vii) of the problem (150) for this  $S$ .

## FURTHER READING

1. Albert, A.A., *A structure theory for Jordan algebras*, Ann. Math.(2), **48**, 546-567 (1947).
2. Albert, A.A., *Non-associative algebra I, II*, Ann. Math.(2), **43**, 685-707, (1942).
3. Baum J.D, *Elements of point set topology*, Prentice-Hall, N.J, 1964.
4. Bernavides, R., Burgueno and Costa, Mallol R., *Some algebras of order four*, Int. J. Math. Game Theory and Algebra, **9**, 159-172 (1999).
5. Birkhoff. G, *Lattice theory*, 2<sup>nd</sup> Edition, Amer-Math Soc. Providence RI 1948.
6. Bruck.R.H., *A survey of binary systems*, Springer-Verlag, (1958).
7. Bruck.R.H., *Some results in the theory of linear non-associative algebra*, Trans. Amer. Math. Soc., **56**, 141-199 (1944).

8. Castillo J., *The Smarandache semigroup*, International Conference on Combinatorial Methods in Mathematics, II meeting of the project 'Algebra, Geometria e Combinatoria', Faculdade de Ciencias da Universidade do Porto, Portugal, 9-11 July 1998.
9. Chang quan, Zhang, *Inner commutative rings*, Sictiuan Dascue Xuebao (Special issue), **26**, 95-97 (1989).
10. Chein, Orin and Goodaire, Edgar G., *Code loops are RA2-loops*, J. Algebra, **130**, 385-387 (1990).
11. Chein, Orin and Goodaire, Edgar G., *Is a right alternative loop ring alternative?*, Algebras, Groups and Geometries, **5**, 297-304 (1988).
12. Chein, Orin and Goodaire, Edgar G., *Isomorphism of loops which have alternative loop rings*, Comm. Algebra, **13**, 1-20 (1985).
13. Chein, Orin and Goodaire, Edgar G., *Loops whose Loop rings are alternative*, Comm. Algebra, **14**, 293-310 (1986).
14. Chein, Orin and Goodaire, Edgar G., *Loops whose loop rings in characteristic two are alternative*, Comm. Algebra, **18**, 659-688 (1990).
15. Chein, Orin and Goodaire, Edgar G., *Minimally non-associative Moufang loops with a unique non-identity commutator are ring alternative*, Comment Math. Univ. Carolinae, **43**, 1-8 (2002).
16. Chein, Orin and Goodaire, Edgar G., *Moufang loops with a unique non-identity commutators*, J. Algebra, **130**, 369-384 (1990).
17. Chein, Orin, *A short note on super nuclear (central) elements of inverse property loops*, Archiv der Mathematik, **33**, 131-132 (1979).
18. Connell, I.G., *On the group ring*, Canadian J. Math., **15**, 650-667 (1936).

19. Costa, Roberto, Grishkov, Alexander, Guzzo Jr., Henrique and Peresi, A. Luiz, *Non-associative algebras and its applications*, Lecture notes in Pure and Applied Mathematics, **211**, Marcel Dekker, (2000).
20. De Graaf, Willem A., *Lie Algebras :Theory and Algorithms*, North-Holland Pub. Co., Amsterdam, (2000).
21. Dubrovin, I.N., *Chain rings*, Rad. Math., **5**, 97-106 (1989).
22. Elduque, Alberto and Hyo, C. Myung, *Mutations of alternative algebras*, Kluwer Acad. Pub., Boston, (1994).
23. Elduque, Alberto, *A note on triality and symmetric composition*, Abh. Math Sem. Univ, Hamburg, **70**, 125-135 (2000).
24. Frappat, L., Sciarrino, A., and Sorba, P., *Dictionary on Lie algebras and superalgebras*, Acad. Press, (2000).
25. Goodaire, Edgar G. and Miles, Cesar Polcino, *Isomorphism of integral alternative loop rings*, Rendiconti Del Circolo Matematico Di Palermo, **37**, 126-135 (1988).
26. Goodaire, Edgar G. and Miles, Cesar Polcino, *Torsion units in alternative loop rings*, Proc. Amer. Math. Soc., **107**, 7-15 (1989).
27. Goodaire, Edgar G. and Parmenter, M.M., *Semi-simplicity of alternative loop rings*, Acta. Math. Hung, **50**, 241-247 (1987).
28. Goodaire, Edgar G. and Parmenter, M.M., *Units in Alternative loop rings*, Israel J. Math., **53**, 209-216 (1986).
29. Goodaire, Edgar G., *Alternative loop rings*, Publications Mathematical Tomus, **30**, 31-38 (1983).
30. Goodaire, Edgar G., *Groups embeddable in alternative loop rings*, Contrib. General Algebra, Verlag, 169-176 (1991).
31. Gray, Mary W., *A radical approach to algebra*, Addison-Wesley, (1970).
32. Hentzel, Irvin Roy, Jacobs, D.P., and Mudddana, Sekhar V., *Experimenting with the identity  $(xy)z = y(zx)$* , (1993)
33. Higman, G., *The units of group rings*, Proc. London Math. Soc., **46**, 231-248 (1940).

34. Iqbal Unnisa and Vasantha Kandasamy, W. B., *Supermodular lattices*, J. Madras Univ., **44**, 58-80 (1981).
35. Jacobson, F.D., and Jacobson, Nathan, *Classification and representation of semi simple Jordan Algebras*, Trans. Amer. Math. Soc., **65**, 141-169 (1949).
36. Jacobson, Nathan, *General representation theory of Jordan algebras*, Trans. Amer. Math. Soc., **70**, 509-530 (1951).
37. Jacobson, Nathan, *Lie algebras*, Interscience Pub. Wiley & Sons, (1962).
38. Jacobson, Nathan, *Structure and representations of Jordan algebras*, Amer. Math. Soc. Colloq Pub., (1968).
39. Johnson, P.L., *The modular group ring of a finite  $p$ -group*, Proc. Amer. Math. Soc., **68**, 19-22 (1978).
40. Koecher, Max, *The Minnesota notes on Jordan algebras and their applications*, Lecture Notes in Matematica, **1710**, Springer Verlag, (1999).
41. Mallol, Cristian and Varro, Richard, *Automorphism and derivations in Jordan algebras of rank 3*, Algebras, Groups and Geometries, **14**, 297-311 (1997). [MR: 2000b, 17042].
42. Matsuda, R.M., *On Marot rings*, Proc. Japan Acad., **60**, 134-138 (1984).
43. Norton, D.A., *Hamiltonian loop*, Proc. Amer. Math. Soc., **3**, 56-65 (1952).
44. Padilla, Raul, *Smarandache algebraic structures*, Bull. Pure Appl. Sci., **17E**, 199-121 (1998).
45. Passman D.S., *The algebraic structure of group rings*, Wiley Interscience, (1977).
46. Ray, Urmie, *A characterization theorem for a certain class of graded Lie superalgebras*, J. Algebra, **229**, 405-434 (2000).
47. Redfield, R.H., *Exponentiation in rings*, Amer. Math. Monthly, **102**, 36-40 (1995).

48. Serre, Jean-Pierre, *Complex semi-simple Lie algebras*, translated from the French by G.A. Jones, Reprint of the 1987 edition, Springer Monographs in Mathematics, Springer Verlag, Berlin, (2001).
49. Shestakov, Ivan P., *Every Akivis algebra is linear*, *Geom. Dedicata*, **77**, 215-223 (1999).
50. Simmons, G.F., *Introduction to topology and Modern Analysis*, McGraw-Hill Book 60 N.Y. 1963.
51. Singh.S.V., *On a new class of loops and loop rings*, PhD thesis (under the guidance of W.B.Vasantha) Indian Institute of Technology, Aug. 1994.
52. Smarandache. F. (editor), *Proceedings of the First International Conference on Neutrosophy*, Neutrosophic Probability and Statistics, Univ. of New Mexico-Gallup, 2001.
53. Solarin, A.R.T, *A short note on Bol algebras*, *Riv. Mat. Pure. Appl.*, **8**, 7-11 (1988).
54. Springer, T.A., *Jordan algebras and algebraic groups*, Springer-Verlag, (1973).
55. Strojnowski, A., *A note on unique product groups*, *Comm. Algebra*, **8**, 235-260 (1980).
56. Sze-Tsen Hu, *Elements of general topology*, Vakils, Feffer and Simons Pvt. Ltd., Bombay, 1970.
57. Vasantha Kandasamy, W. B., *On Smarandache Non-Associative rings*, (2002).
58. Vasantha Kandasamy, W. B., *A note on the modular group ring of a finite p-group*, *Kyungpook Math. J.*, **26**, 163-166 (1986).
59. Vasantha Kandasamy, W. B., *A note on the modular loop ring of a finite loop*, *Opuscula Math.*, **15**, 109-112 (1995).
60. Vasantha Kandasamy, W. B., *Idempotents in rational loop algebras*, *Ganit*, **12**, 53-56 (1992).
61. Vasantha Kandasamy, W. B., *Loop algebras of Moufang loops*, *Math Forum*, **11**, 21-25 (1997).



62. Vasantha Kandasamy, W. B., *New classes of finite groupoids using  $Z_n$* , Varahmihir J. Math. Sci., **1**, 135-143 (2001).
63. Vasantha Kandasamy, W. B., *On a new class of Jordan loops and their loop rings*, J. Bihar Math. Soc., **19**, 71-75 (1999).
64. Vasantha Kandasamy, W. B., *On loop rings which are Marot loop rings*, U. Sci Phys. Sci., **7**, 224-226 (1995).
65. Vasantha Kandasamy, W. B., *On normal elements in loop rings*, U. Sci. Phys. Sci., **4**, 210-212 (1992).
66. Vasantha Kandasamy, W. B., *On ordered groupoids and groupoid rings*, J. Math. and Comp. Sci., **9**, 145-147, (1996).
67. Vasantha Kandasamy, W. B., *On strictly right loop rings*, J. Harbin Inst. Sci. Tech., **18**, 116-118 (1994).
68. Vasantha Kandasamy, W. B., *On zero divisors in reduced group rings over ordered rings*, Proc. Japan Acad., **60**, No.9, 333-334 (1984).
69. Vasantha Kandasamy, W. B., *Semi idempotents in loop algebra*, J. Inst. Math. Comp. Sci., **7**, 241-244 (1994).
70. Vasantha Kandasamy, W. B., *Smarandache groupoids*, American Research Press, Rehoboth, (2002).
71. Vasantha Kandasamy, W. B., *Smarandache Loops*, American Research Press, Rehoboth, (2002).
72. Vasantha Kandasamy, W. B., *Smarandache Loops*, Smarandache Notions Journal, **13**, 252-258 (2002).
73. Vasantha Kandasamy, W. B., *Smarandache non associative rings*, American Research Press, (2001)
74. Vasantha Kandasamy, W. B., *Units in loop rings*, U. Sci. Phys. Sci., **5**, 86-88 (1993).
75. Vasantha Kandasamy, W. B., *Zero divisors in loop algebras of power associative and di associative loops*, Acta Politechnica Praze, CVUT, Praze, **16**, 21-26 (1991).

76. Vasantha Kandasamy, W.B., *Linear Algebra and Smarandache Linear Algebra*, Bookman Publishing, US, 2003.
77. Vasantha Kandasamy, W.B., *Smarandache Rings*, American Research Press, Rehoboth, 2002.
78. Vasantha Kandasamy, W.B., *Smarandache Semigroups*, American Research Press, Rehoboth, 2002.
79. Vasantha Kandasamy, W.B., *Smarandache Semirings, Semifields and Semivector spaces*, American Research Press, Rehoboth, 2002.
80. Vasantha Kandasamy, W.B. and Florentin Smarandache, *Neutrosophic Rings*, Hexis, Arizona, 2006.
81. Vasantha Kandasamy, W.B. and Florentin Smarandache, *Set Linear Algebra and Set Fuzzy Linear Algebra*, InfoLearnQuest, Phoenix, 2008.
82. Vasantha Kandasamy, W.B. and Florentin Smarandache, *Finite Neutrosophic Complex Numbers*, Zip Publishing, Ohio, 2011.
83. Vasantha Kandasamy, W.B. and Florentin Smarandache, *Dual Numbers*, Zip Publishing, Ohio, 2012.
84. Vasantha Kandasamy, W.B. and Florentin Smarandache, *Natural Product  $\times_n$  on matrices*, Zip Publishing, Ohio, 2012.
85. Vasantha Kandasamy, W.B. and Florentin Smarandache, *Quasi Set Topological Vector Subspaces*, Educational Publisher Inc, Ohio, 2012.
86. Vasantha Kandasamy, W.B. and Florentin Smarandache, *Set Ideal Topological Spaces*, Zip Publishing, Ohio, 2012.
87. Vasantha Kandasamy, W.B. and Florentin Smarandache, *Special dual like numbers and lattices*, Zip Publishing, Ohio, 2012.
88. Vasantha Kandasamy, W.B. and Florentin Smarandache, *Special quasi dual numbers and groupoids*, Zip Publishing, Ohio, 2012.

89. Vasantha Kandasamy, W.B. and Florentin Smarandache, *Algebraic Structures using Subsets*, Educational Publisher Inc, Ohio, 2013.
90. Vasantha Kandasamy, W. B. and Florentin Smarandache, *Subset Polynomial Semirings and Subset Matrix Semirings*, Educational Publisher Inc, 2013.
91. Wan, Zhe-xian, *Lie algebras* (translated by Che Young Lee), Pergamon press, (1975).

# INDEX

## A

Argumentation subset ideal, 111-9

## C

Closed subset net, 47-9

Conjugate subset non associative subsemirings, 40-9

## D

Dual numbers, 9-10

## F

Finite groupoids, 9-10

Finite neutrosophic complex modulo integers, 9-10

## I

Inner commutative subset semiring, 40-8

## L

Left quasi regular element, 101-6

Left subset semiring semiideal, 44-8

Loops, 9-10

**N**

- Neutrosophic rings, 9-10
- New non associative special topology, 53-5
- New non associative subset topological space of a loop semiring, 137-9
- New subset semiring ideal non associative topological space of a subset semiring, 56-9
- New subset semiring ideal topological space of a subset semirings, 56-9
- New subset subsemiring topological space, 58-61
- Non associative semiring, 9-10
- Non associative subset semiring of a loop ring, 95-9
- Non associative subset semiring, 98-102
- Normal subset non associative semiring, 37-9
- Normal subset subring, 37-9

**R**

- Right quasi regular element, 101-5

**S**

- S-additive subset semigroup of a subset semiring, 44-9
- Semi Smarandache subset non associative semiring, 31-7
- Semipseudo subset idempotent, 122-7
- Semirings, 9-10
- S-essential subset subsemiring, 50-5
- S-essential subset subsemiring, 50-5
- Set subset ideal of a subset semiring, 59-62
- Set subset left semiring ideal of a subset semirings, 59-63
- Set subset right semiring ideal of a subset semiring, 56-60
- Smarandache groupoid ring, 31-6
- Smarandache idempotents, 9-10
- Smarandache n-capacitor group, 44-9
- Smarandache one way weakly subset subsemiring link, 50-7
- Smarandache pseudo commutative pair, 46-9
- Smarandache pseudo commutative subset semiring, 46-9

Smarandache radical subset semiring ideal, 49-52  
 Smarandache rings, 9-10  
 Smarandache semirings, 9-10  
 Smarandache strong subset non associative semiring, 31-7  
 Smarandache subset idempotent, 122-8  
 Smarandache subset left quasi regular element, 101-9  
 Smarandache subset mod  $p$  envelope, 133-8  
 Smarandache subset non associative semiring, 31-5  
 Smarandache subset pseudo zero divisor, 124-8  
 Smarandache subset right quasi regular element, 101-9  
 Smarandache subset semi idempotent, 128-132  
 Smarandache subset semiring left semi ideal, 44-9  
 Smarandache subset semiring semi ideal, 44-50  
 Smarandache subset weak zero divisor, 126-9  
 Smarandache weak subset subsemiring link, 50-8  
 Smarandache zero divisors, 9-10  
 Special dual like numbers, 9-10  
 Special quasi dual number, 9-10  
 S-subset semiring, 46-9  
 Strictly non commutative subset subsemiring, 42-9  
 Strong subset semiring left semiideal, 44-9  
 Strong subset semiring right semiideal, 44-9  
 Subset commutative non associative semiring, 12-9  
 Subset idempotents, 16-27  
 Subset left ideal semiring of a subset semiring, 25-9  
 Subset left quasi regular element, 101-9  
 Subset mod  $p$  envelope of a subset loop ring, 133-8  
 Subset non associative non commutative semiring, 17-25  
 Subset non associative semiring of finite order, 12-8  
 Subset non associative semiring of infinite order, 13-9  
 Subset non associative semiring topologies, 53-6  
 Subset non associative semiring, 11-6  
 Subset right ideal semiring of a subset semiring, 25-9  
 Subset right quasi regular element, 101-9  
 Subset semi idempotent, 128-132  
 Subset semiring ideal of a subset semiring, 23-9  
 Subset semiring topological space, 134-6  
 Subset subring left link, 49-52  
 Subset subring right link, 50-3

Subset subsemiring, 19-23

Subset zero divisors, 15-25

## **T**

Topological space of subset semirings, 50-6

## **W**

Weakly inner commutative subset semiring, 40-8

Weakly subst subsemiring link, 50-5

## ABOUT THE AUTHORS

**Dr.W.B.Vasantha Kandasamy** is a Professor in the Department of Mathematics, Indian Institute of Technology Madras, Chennai. In the past decade she has guided 13 Ph.D. scholars in the different fields of non-associative algebras, algebraic coding theory, transportation theory, fuzzy groups, and applications of fuzzy theory of the problems faced in chemical industries and cement industries. She has to her credit 646 research papers. She has guided over 100 M.Sc. and M.Tech. projects. She has worked in collaboration projects with the Indian Space Research Organization and with the Tamil Nadu State AIDS Control Society. She is presently working on a research project funded by the Board of Research in Nuclear Sciences, Government of India. This is her 84<sup>th</sup> book.

On India's 60th Independence Day, Dr.Vasantha was conferred the Kalpana Chawla Award for Courage and Daring Enterprise by the State Government of Tamil Nadu in recognition of her sustained fight for social justice in the Indian Institute of Technology (IIT) Madras and for her contribution to mathematics. The award, instituted in the memory of Indian-American astronaut Kalpana Chawla who died aboard Space Shuttle Columbia, carried a cash prize of five lakh rupees (the highest prize-money for any Indian award) and a gold medal. She can be contacted at [vasanthakandasamy@gmail.com](mailto:vasanthakandasamy@gmail.com)  
Web Site: [http://mat.iitm.ac.in/home/wbv/public\\_html/](http://mat.iitm.ac.in/home/wbv/public_html/)  
or <http://www.vasantha.in>

---

**Dr. Florentin Smarandache** is a Professor of Mathematics at the University of New Mexico in USA. He published over 75 books and 200 articles and notes in mathematics, physics, philosophy, psychology, rebus, literature. In mathematics his research is in number theory, non-Euclidean geometry, synthetic geometry, algebraic structures, statistics, neutrosophic logic and set (generalizations of fuzzy logic and set respectively), neutrosophic probability (generalization of classical and imprecise probability). Also, small contributions to nuclear and particle physics, information fusion, neutrosophy (a generalization of dialectics), law of sensations and stimuli, etc. He got the 2010 Telesio-Galilei Academy of Science Gold Medal, Adjunct Professor (equivalent to Doctor Honoris Causa) of Beijing Jiaotong University in 2011, and 2011 Romanian Academy Award for Technical Science (the highest in the country). Dr. W. B. Vasantha Kandasamy and Dr. Florentin Smarandache got the 2012 New Mexico-Arizona and 2011 New Mexico Book Award for Algebraic Structures. He can be contacted at [smarand@unm.edu](mailto:smarand@unm.edu)



**In this book the authors introduce the notion of subset non associative semirings. It is pertinent to keep on record that study of non associative semirings is meager and books on this specific topic are still rare. Some open problems are suggested in this book.**

US \$35.00  
Educational  
Publisher Inc.

ISBN 9781599732251



9 781599 732251

90000 >

