

An Isolated Interval Valued Neutrosophic Graph

Said Broumi¹, Assia Bakali², Mohamed Talea³,
Florentin Smarandache⁴

¹ University Hassan II, Sidi Othman, Casablanca, Morocco
broumisaid78@gmail.com

² University Hassan II, Sidi Othman, Casablanca, Morocco
taleamohamed@yahoo.fr

³ Ecole Royale Navale, Casablanca, Morocco
assiabakali@yahoo.fr

⁴ University of New Mexico, Gallup, USA
fsmarandache@gmail.com

Abstract

The interval valued neutrosophic graphs are generalizations of the fuzzy graphs, interval fuzzy graphs, interval valued intuitionistic fuzzy graphs, and single valued neutrosophic graphs. Previously, several results have been proved on the isolated graphs and the complete graphs. In this paper, a necessary and sufficient condition for an interval valued neutrosophic graph to be an isolated interval valued neutrosophic graph is proved.

Keyword

interval valued neutrosophic graphs, complete interval valued neutrosophic graphs, isolated interval valued neutrosophic graphs.

1 Introduction

To express indeterminate and inconsistent information which exists in real world, Smarandache [9] originally proposed the concept of the neutrosophic set from a philosophical point of view. The concept of the neutrosophic set (NS) is a generalization of the theories of fuzzy sets [14], intuitionistic fuzzy sets [15], interval valued fuzzy set [12] and interval-valued intuitionistic fuzzy sets [14].

The neutrosophic sets are characterized by a truth-membership function (t), an indeterminacy-membership function (i) and a falsity-membership function (f) independently, which are within the real standard or nonstandard unit interval $]0, 1+[$.

Further on, Wang et al. [10] introduced the concept of a single-valued neutrosophic sets (SVNS), a subclass of the neutrosophic sets. The same authors [11] introduced the interval valued neutrosophic sets (IVNS), as a generalization of the single valued neutrosophic sets, in which three membership functions are independent and their value belong to the unit interval $[0, 1]$. Some more work on single valued neutrosophic sets, interval valued neutrosophic sets, and their applications, may be found in [1, 5, 7,8, 29, 30, 31, 37, 38].

Graph theory has become a major branch of applied mathematics, and it is generally regarded as a branch of combinatorics. Graph is a widely-used tool for solving combinatorial problems in different areas, such as geometry, algebra, number theory, topology, optimization and computer science. Most important thing which is to be noted is that, when we have uncertainty regarding either the set of vertices, or edges, or both, the model becomes a fuzzy graph.

In the literature, many extensions of fuzzy graphs have been deeply studied by several researchers, such as intuitionistic fuzzy graphs, interval valued fuzzy graphs, interval valued intuitionistic fuzzy graphs [2, 3, 16, 17, 18, 19, 20, 21, 22, 34].

But, when the relations between nodes (or vertices) in problems are indeterminate and inconsistent, the fuzzy graphs and their extensions fail. To overcome this issue Smarandache [5, 6, 7, 37] have defined four main categories of neutrosophic graphs: two are based on literal indeterminacy (I), (the I-edge neutrosophic graph and the I-vertex neutrosophic graph, [6, 36]), and the two others graphs are based on (t, i, f) components (the (t, i, f)-edge neutrosophic graph and the (t, i, f)-vertex neutrosophic graph, not developed yet).

Later, Broumi et al. [23] presented the concept of single valued neutrosophic graphs by combining the single valued neutrosophic set theory and the graph theory, and defined different types of single valued neutrosophic graphs (SVNG) including the strong single valued neutrosophic graph, the constant single valued neutrosophic graph, the complete single valued neutrosophic graph, and investigated some of their properties with proofs and suitable illustrations.

Concepts like size, order, degree, total degree, neighborhood degree and closed neighborhood degree of vertex in a single valued neutrosophic graph are introduced, along with theoretical analysis and examples, by Broumi al. in [24]. In addition, Broumi et al. [25] introduced the concept of isolated single valued neutrosophic graphs. Using the concepts of bipolar neutrosophic sets, Broumi et al. [32] also introduced the concept of bipolar single neutrosophic graph, as the generalization of the bipolar fuzzy graphs, N-graphs,

intuitionistic fuzzy graph, single valued neutrosophic graphs and bipolar intuitionistic fuzzy graphs. Same authors [33] proposed different types of bipolar single valued neutrosophic graphs, such as bipolar single valued neutrosophic graphs, complete bipolar single valued neutrosophic graphs, regular bipolar single valued neutrosophic graphs, studying some of their related properties. Moreover, in [26, 27, 28], the authors introduced the concept of interval valued neutrosophic graph as a generalization of fuzzy graph, intuitionistic fuzzy graph and single valued neutrosophic graph, and discussed some of their properties with examples.

The aim of this paper is to prove a necessary and sufficient condition for an interval valued neutrosophic graph to be an isolated interval valued neutrosophic graph.

2 Preliminaries

In this section, we mainly recall some notions related to neutrosophic sets, single valued neutrosophic sets, fuzzy graph, intuitionistic fuzzy graph, single valued neutrosophic graphs and interval valued neutrosophic graph, relevant to the present work. See especially [2, 9, 10, 22, 23, 26] for further details and background.

Definition 2.1 [9]

Let X be a space of points (objects) with generic elements in X denoted by x ; then the neutrosophic set A (NS A) is an object having the form $A = \{ \langle x: T_A(x), I_A(x), F_A(x) \rangle, x \in X \}$, where the functions $T, I, F: X \rightarrow]-0, 1+[$ define respectively the a truth-membership function, an indeterminacy-membership function, and a falsity-membership function of the element $x \in X$ to the set A with the condition:

$$-0 \leq T_A(x) + I_A(x) + F_A(x) \leq 3^+ \tag{1}$$

The functions $T_A(x)$, $I_A(x)$ and $F_A(x)$ are real standard or nonstandard subsets of $]0, 1+[$.

Since it is difficult to apply NSs to practical problems, Wang et al. [10] introduced the concept of a SVNS, which is an instance of a NS, and can be used in real scientific and engineering applications.

Definition 2.2 [10]

Let X be a space of points (objects) with generic elements in X denoted by x . A single valued neutrosophic set A (SVNS A) is characterized by the truth-membership function $T_A(x)$, an indeterminacy-membership function $I_A(x)$,

and a falsity-membership function $F_A(x)$. For each point x in X , $T_A(x), I_A(x), F_A(x) \in [0, 1]$. A SVNS A can be written as

$$A = \{ \langle x: T_A(x), I_A(x), F_A(x) \rangle, x \in X \} \tag{2}$$

Definition 2.3 [2]

A fuzzy graph is a pair of functions $G = (\sigma, \mu)$ where σ is a fuzzy subset of a non-empty set V and μ is a symmetric fuzzy relation on σ , i.e. $\sigma : V \rightarrow [0,1]$ and $\mu : V \times V \rightarrow [0,1]$ such that $\mu(uv) \leq \sigma(u) \wedge \sigma(v)$, for all $u, v \in V$, where uv denotes the edge between u and v and $\sigma(u) \wedge \sigma(v)$ denotes the minimum of $\sigma(u)$ and $\sigma(v)$. σ is called the fuzzy vertex set of V and μ is called the fuzzy edge set of E .

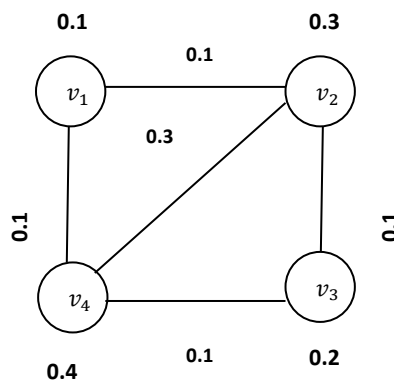

Figure 1. Fuzzy Graph.

Definition 2.4 [2]

The fuzzy subgraph $H = (\tau, \rho)$ is called a fuzzy subgraph of $G = (\sigma, \mu)$ if $\tau(u) \leq \sigma(u)$ for all $u \in V$ and $\rho(u, v) \leq \mu(u, v)$ for all $u, v \in V$.

Definition 2.5 [22]

An intuitionistic fuzzy graph is of the form $G = (V, E)$, where:

- i. $V = \{v_1, v_2, \dots, v_n\}$ such that $\mu_1 : V \rightarrow [0,1]$ and $\gamma_1 : V \rightarrow [0,1]$ denote the degree of membership and nonmembership of the element $v_i \in V$, respectively, and $0 \leq \mu_1(v_i) + \gamma_1(v_i) \leq 1$ for every $v_i \in V$, ($i = 1, 2, \dots, n$);
- ii. $E \subseteq V \times V$ where $\mu_2 : V \times V \rightarrow [0,1]$ and $\gamma_2 : V \times V \rightarrow [0,1]$ are such that $\mu_2(v_i, v_j) \leq \min [\mu_1(v_i), \mu_1(v_j)]$ and $\gamma_2(v_i, v_j) \geq \max [\gamma_1(v_i), \gamma_1(v_j)]$ and $0 \leq \mu_2(v_i, v_j) + \gamma_2(v_i, v_j) \leq 1$ for every $(v_i, v_j) \in E$, ($i, j = 1, 2, \dots, n$).

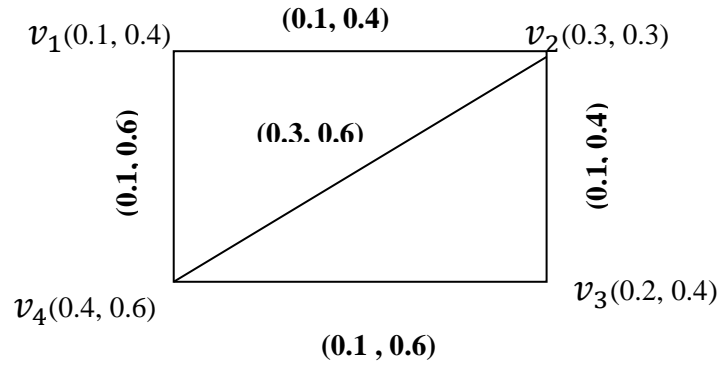

Figure 2. Intuitionistic Fuzzy Graph.

Definition 2.5 [23]

Let $A = (T_A, I_A, F_A)$ and $B = (T_B, I_B, F_B)$ be two single valued neutrosophic sets on a set X . If $A = (T_A, I_A, F_A)$ is a single valued neutrosophic relation on a set X , then $A = (T_A, I_A, F_A)$ is called a single valued neutrosophic relation on $B = (T_B, I_B, F_B)$ if

$$T_B(x, y) \leq \min(T_A(x), T_A(y)), \tag{3}$$

$$I_B(x, y) \geq \max(I_A(x), I_A(y)), \tag{4}$$

$$F_B(x, y) \geq \max(F_A(x), F_A(y)), \tag{5}$$

for all $x, y \in X$.

A single valued neutrosophic relation A on X is called symmetric if $T_A(x, y) = T_A(y, x)$, $I_A(x, y) = I_A(y, x)$, $F_A(x, y) = F_A(y, x)$ and $T_B(x, y) = T_B(y, x)$, $I_B(x, y) = I_B(y, x)$ and $F_B(x, y) = F_B(y, x)$, for all $x, y \in X$.

Definition 2.6 [23]

A single valued neutrosophic graph (SVN-graph) with underlying set V is defined to be a pair $G = (A, B)$, where:

1. The functions $T_A: V \rightarrow [0, 1]$, $I_A: V \rightarrow [0, 1]$ and $F_A: V \rightarrow [0, 1]$ denote the degree of truth-membership, degree of indeterminacy-membership and falsity-membership of the element $v_i \in V$, respectively, and:

$$0 \leq T_A(v_i) + I_A(v_i) + F_A(v_i) \leq 3 \tag{6}$$

for all $v_i \in V$ ($i = 1, 2, \dots, n$).

2. The functions $T_B: E \subseteq V \times V \rightarrow [0, 1]$, $I_B: E \subseteq V \times V \rightarrow [0, 1]$ and $F_B: E \subseteq V \times V \rightarrow [0, 1]$ are defined by:

$$T_B(\{v_i, v_j\}) \leq \min [T_A(v_i), T_A(v_j)], \tag{7}$$

$$I_B(\{v_i, v_j\}) \geq \max [I_A(v_i), I_A(v_j)], \quad (8)$$

$$F_B(\{v_i, v_j\}) \geq \max [F_A(v_i), F_A(v_j)], \quad (9)$$

denoting the degree of truth-membership, indeterminacy-membership and falsity-membership of the edge $(v_i, v_j) \in E$ respectively, where:

$$0 \leq T_B(\{v_i, v_j\}) + I_B(\{v_i, v_j\}) + F_B(\{v_i, v_j\}) \leq 3 \quad \text{for all } \{v_i, v_j\} \in E \quad (i, j = 1, 2, \dots, n) \quad (10)$$

We have A - the single valued neutrosophic vertex set of V, and B - the single valued neutrosophic edge set of E, respectively. Note that B is a symmetric single valued neutrosophic relation on A. We use the notation (v_i, v_j) for an element of E. Thus, $G = (A, B)$ is a single valued neutrosophic graph of $G^* = (V, E)$ if:

$$T_B(v_i, v_j) \leq \min [T_A(v_i), T_A(v_j)], \quad (11)$$

$$I_B(v_i, v_j) \geq \max [I_A(v_i), I_A(v_j)], \quad (12)$$

$$F_B(v_i, v_j) \geq \max [F_A(v_i), F_A(v_j)], \quad (13)$$

for all $(v_i, v_j) \in E$.

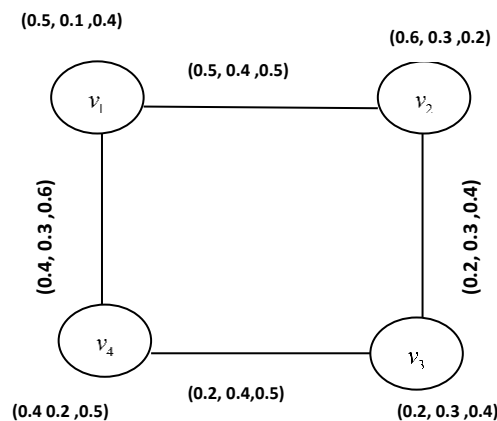

Figure 3. Single valued neutrosophic graph.

Definition 2.7 [23]

A single valued neutrosophic graph $G = (A, B)$ is called complete if:

$$T_B(v_i, v_j) = \min [T_A(v_i), T_A(v_j)] \quad (14)$$

$$I_B(v_i, v_j) = \max [I_A(v_i), I_A(v_j)] \quad (15)$$

$$F_B(v_i, v_j) = \max [F_A(v_i), F_A(v_j)] \quad (16)$$

for all $v_i, v_j \in V$.

Definition 2.8 [23]

The complement of a single valued neutrosophic graph $G(A, B)$ on G^* is a single valued neutrosophic graph \bar{G} on G^* , where:

$$1. \bar{A} = A. \tag{17}$$

$$2. \bar{T}_A(v_i) = T_A(v_i), \bar{I}_A(v_i) = I_A(v_i), \bar{F}_A(v_i) = F_A(v_i), \tag{18}$$

for all $v_j \in V$.

$$3. \bar{T}_B(v_i, v_j) = \min [T_A(v_i), T_A(v_j)] - T_B(v_i, v_j), \tag{19}$$

$$\bar{I}_B(v_i, v_j) = \max [I_A(v_i), I_A(v_j)] - I_B(v_i, v_j), \tag{20}$$

$$\bar{F}_B(v_i, v_j) = \max [F_A(v_i), F_A(v_j)] - F_B(v_i, v_j), \tag{21}$$

for all $(v_i, v_j) \in E$.

Definition 2.9 [26]

By an interval-valued neutrosophic graph of a graph $G^* = (V, E)$ we mean a pair $G = (A, B)$, where $A = \langle [T_{AL}, T_{AU}], [I_{AL}, I_{AU}], [F_{AL}, F_{AU}] \rangle$ is an interval-valued neutrosophic set on V and $B = \langle [T_{BL}, T_{BU}], [I_{BL}, I_{BU}], [F_{BL}, F_{BU}] \rangle$ is an interval valued neutrosophic relation on E , satisfying the following condition:

1. $V = \{v_1, v_2, \dots, v_n\}$ such that $T_{AL}:V \rightarrow [0, 1]$, $T_{AU}:V \rightarrow [0, 1]$, $I_{AL}:V \rightarrow [0, 1]$, $I_{AU}:V \rightarrow [0, 1]$ and $F_{AL}:V \rightarrow [0, 1]$, $F_{AU}:V \rightarrow [0, 1]$, denoting the degree of truth-membership, the degree of indeterminacy-membership and falsity-membership of the element $y \in V$, respectively, and:

$$0 \leq T_A(v_i) + I_A(v_i) + F_A(v_i) \leq 3, \tag{22}$$

for all $v_i \in V (i=1, 2, \dots, n)$

2. The functions $T_{BL}:V \times V \rightarrow [0, 1]$, $T_{BU}:V \times V \rightarrow [0, 1]$, $I_{BL}:V \times V \rightarrow [0, 1]$, $I_{BU}:V \times V \rightarrow [0, 1]$ and $F_{BL}:V \times V \rightarrow [0, 1]$, $F_{BU}:V \times V \rightarrow [0, 1]$ are such that:

$$T_{BL}(\{v_i, v_j\}) \leq \min [T_{AL}(v_i), T_{AL}(v_j)], \tag{23}$$

$$T_{BU}(\{v_i, v_j\}) \leq \min [T_{AU}(v_i), T_{AU}(v_j)], \tag{24}$$

$$I_{BL}(\{v_i, v_j\}) \geq \max [I_{BL}(v_i), I_{BL}(v_j)], \tag{25}$$

$$I_{BU}(\{v_i, v_j\}) \geq \max [I_{BU}(v_i), I_{BU}(v_j)], \tag{26}$$

$$F_{BL}(\{v_i, v_j\}) \geq \max [F_{BL}(v_i), F_{BL}(v_j)], \tag{27}$$

$$F_{BU}(\{v_i, v_j\}) \geq \max [F_{BU}(v_i), F_{BU}(v_j)], \tag{28}$$

denoting the degree of truth-membership, indeterminacy-membership and falsity-membership of the edge $(v_i, v_j) \in E$ respectively, where:

$$0 \leq T_B(\{v_i, v_j\}) + I_B(\{v_i, v_j\}) + F_B(\{v_i, v_j\}) \leq 3, \tag{29}$$

for all $\{v_i, v_j\} \in E$ ($i, j = 1, 2, \dots, n$).

We have A - the interval valued neutrosophic vertex set of V , and B - the interval valued neutrosophic edge set of E , respectively. Note that B is a symmetric interval valued neutrosophic relation on A . We use the notation (v_i, v_j) for an element of E . Thus, $G = (A, B)$ is an interval valued neutrosophic graph of $G^* = (V, E)$, if:

$$T_{BL}(v_i, v_j) \leq \min [T_{AL}(v_i), T_{AL}(v_j)], \tag{30}$$

$$T_{BU}(v_i, v_j) \leq \min [T_{AU}(v_i), T_{AU}(v_j)], \tag{31}$$

$$I_{BL}(v_i, v_j) \geq \max [I_{BL}(v_i), I_{BL}(v_j)], \tag{32}$$

$$I_{BU}(v_i, v_j) \geq \max [I_{BU}(v_i), I_{BU}(v_j)], \tag{33}$$

$$F_{BL}(v_i, v_j) \geq \max [F_{BL}(v_i), F_{BL}(v_j)], \tag{34}$$

$$F_{BU}(v_i, v_j) \geq \max [F_{BU}(v_i), F_{BU}(v_j)], \tag{35}$$

for all $(v_i, v_j) \in E$.

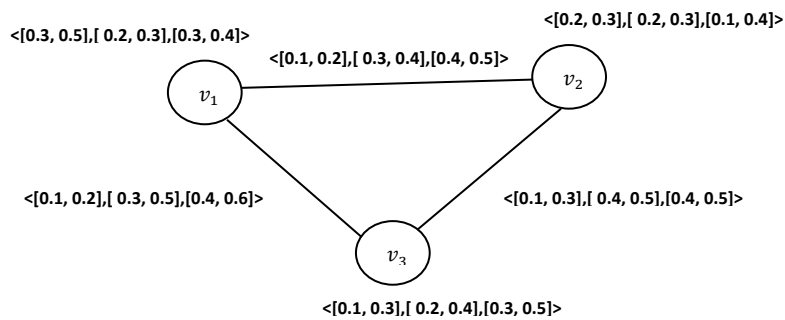

Figure 4. Interval valued neutrosophic graph.

Definition 2.10 [26]

The complement of a complete interval valued neutrosophic graph $G = (A, B)$ of $G^* = (V, E)$ is a complete interval valued neutrosophic graph $\bar{G} = (\bar{A}, \bar{B}) = (A, \bar{B})$ on $G^* = (V, \bar{E})$, where:

$$1. \bar{V} = V \tag{36}$$

$$2. \bar{T}_{AL}(v_i) = T_{AL}(v_i), \tag{37}$$

$$\bar{T}_{AU}(v_i) = T_{AU}(v_i), \tag{38}$$

$$\bar{I}_{AL}(v_i) = I_{AL}(v_i), \tag{39}$$

$$\bar{I}_{AU}(v_i) = I_{AU}(v_i), \tag{40}$$

$$\overline{F_{AL}}(v_i) = F_{AL}(v_i), \tag{41}$$

$$\overline{F_{AU}}(v_i) = F_{AU}(v_i), \tag{42}$$

for all $v_j \in V$.

$$3. \overline{T_{BL}}(v_i, v_j) = \min [T_{AL}(v_i), T_{AL}(v_j)] - T_{BL}(v_i, v_j), \tag{43}$$

$$\overline{T_{BU}}(v_i, v_j) = \min [T_{AU}(v_i), T_{AU}(v_j)] - T_{BU}(v_i, v_j), \tag{44}$$

$$\overline{I_{BL}}(v_i, v_j) = \max [I_{AL}(v_i), I_{AL}(v_j)] - I_{BL}(v_i, v_j), \tag{45}$$

$$\overline{I_{BU}}(v_i, v_j) = \max [I_{AU}(v_i), I_{AU}(v_j)] - I_{BU}(v_i, v_j), \tag{46}$$

$$\overline{F_{BL}}(v_i, v_j) = \max [F_{AL}(v_i), F_{AL}(v_j)] - F_{BL}(v_i, v_j), \tag{47}$$

$$\overline{F_{BU}}(v_i, v_j) = \max [F_{AU}(v_i), F_{AU}(v_j)] - F_{BU}(v_i, v_j), \tag{48}$$

for all $(v_i, v_j) \in E$.

Definition 2.11 [26]

An interval valued neutrosophic graph $G = (A, B)$ is called complete, if:

$$T_{BL}(v_i, v_j) = \min(T_{AL}(v_i), T_{AL}(v_j)), \tag{49}$$

$$T_{BU}(v_i, v_j) = \min(T_{AU}(v_i), T_{AU}(v_j)), \tag{50}$$

$$I_{BL}(v_i, v_j) = \max (I_A(v_i), I_A(v_j)), \tag{51}$$

$$I_{BU}(v_i, v_j) = \max (I_{AU}(v_i), I_{AU}(v_j)), \tag{52}$$

$$F_{BL}(v_i, v_j) = \max (F_A(v_i), F_A(v_j)), \tag{53}$$

$$F_{BU}(v_i, v_j) = \max (F_{AU}(v_i), F_{AU}(v_j)), \tag{54}$$

for all $v_i, v_j \in V$.

3 Main Result

Theorem 3.1:

An interval valued neutrosophic graph $G = (A, B)$ is an isolated interval valued neutrosophic graph if and only if its complement is a complete interval valued neutrosophic graph.

Proof

Let $G = (A, B)$ be a complete interval valued neutrosophic graph.

Therefore:

$$T_{BL}(v_i, v_j) = \min(T_{AL}(v_i), T_{AL}(v_j)), \quad (55)$$

$$T_{BU}(v_i, v_j) = \min(T_{AU}(v_i), T_{AU}(v_j)), \quad (56)$$

$$I_{BL}(v_i, v_j) = \max(I_{AL}(v_i), I_{AL}(v_j)), \quad (57)$$

$$I_{BU}(v_i, v_j) = \max(I_{AU}(v_i), I_{AU}(v_j)), \quad (58)$$

$$F_{BL}(v_i, v_j) = \max(F_{AL}(v_i), F_{AL}(v_j)), \quad (59)$$

$$F_{BU}(v_i, v_j) = \max(F_{AU}(v_i), F_{AU}(v_j)), \quad (60)$$

for all $v_i, v_j \in V$.

Hence in \bar{G} ,

$$\bar{T}_{BL}(v_i, v_j) = \min(T_{AL}(v_i), T_{AL}(v_j)) - T_{BL}(v_i, v_j) \quad (61)$$

for all i, j, \dots, n .

$$= \min(T_{AL}(v_i), T_{AL}(v_j)) - \min(T_{AL}(v_i), T_{AL}(v_j)) \quad (62)$$

for all i, j, \dots, n .

$$= 0 \quad (63)$$

for all i, j, \dots, n .

$$\bar{T}_{BU}(v_i, v_j) = \min(T_{AU}(v_i), T_{AU}(v_j)) - T_{BU}(v_i, v_j) \quad (64)$$

for all i, j, \dots, n .

$$= \min(T_{AU}(v_i), T_{AU}(v_j)) - \min(T_{AU}(v_i), T_{AU}(v_j)) \quad (65)$$

for all i, j, \dots, n .

$$= 0 \quad (66)$$

for all i, j, \dots, n .

And:

$$\bar{I}_{BL}(v_i, v_j) = \max(I_{AL}(v_i), I_{AL}(v_j)) - I_{BL}(v_i, v_j) \quad (67)$$

for all i, j, \dots, n .

$$= \max(I_{AL}(v_i), I_{AL}(v_j)) - \max(I_{AL}(v_i), I_{AL}(v_j)) \quad (68)$$

for all i, j, \dots, n .

$$= 0 \quad (69)$$

for all i, j, \dots, n .

$$\bar{I}_{BU}(v_i, v_j) = \max(I_{AU}(v_i), I_{AU}(v_j)) - I_{BU}(v_i, v_j) \quad (70)$$

for all i, j, \dots, n .

$$= \max(I_{AU}(v_i), I_{AU}(v_j)) - \max(I_{AU}(v_i), I_{AU}(v_j)) \quad (71)$$

for all i, j, \dots, n .

$$= 0 \tag{72}$$

for all i, j, \dots, n .

Also:

$$\bar{F}_{BL}(v_i, v_j) = \max(F_{AL}(v_i), F_{AL}(v_j)) - F_{BL}(v_i, v_j) \tag{73}$$

for all i, j, \dots, n .

$$= \max(F_{AL}(v_i), F_{AL}(v_j)) - \max(F_{AL}(v_i), F_{AL}(v_j)) \tag{74}$$

for all i, j, \dots, n .

$$= 0 \tag{75}$$

for all i, j, \dots, n .

$$\bar{F}_{BU}(v_i, v_j) = \max(F_{AU}(v_i), F_{AU}(v_j)) - F_{BU}(v_i, v_j) \tag{76}$$

for all i, j, \dots, n .

$$= \max(F_{AU}(v_i), F_{AU}(v_j)) - \max(F_{AU}(v_i), F_{AU}(v_j)) \tag{77}$$

for all i, j, \dots, n .

$$= 0 \tag{78}$$

for all i, j, \dots, n .

Thus,

$$([\bar{T}_{BL}(v_i, v_j), \bar{T}_{BU}(v_i, v_j)], [\bar{I}_{BL}(v_i, v_j), \bar{I}_{BU}(v_i, v_j)], [\bar{F}_{BL}(v_i, v_j), \bar{F}_{BU}(v_i, v_j)]) = ([0, 0], [0, 0], [0, 0]). \tag{79}$$

Hence, $G = (A, B)$ is an isolated interval valued neutrosophic graph.

4 Conclusions

In this paper, we extended the concept of isolated single valued neutrosophic graph to an isolated interval valued neutrosophic graph. In future works, we plan to study the concept of isolated bipolar single valued neutrosophic graph.

6 References

- [1] A. V. Devadoss, A. Rajkumar & N. J. P.Praveena. *A Study on Miracles through Holy Bible using Neutrosophic Cognitive Maps (NCMS)*. In: International Journal of Computer Applications, 69 (3) (2013).
- [2] A. Nagoor Gani. M. B. Ahamed. *Order and Size in Fuzzy Graphs*. In: Bulletin of Pure and Applied Sciences, Vol 22E (No. 1) (2003), pp. 145-148.

- [3] A. N. Gani. A and S. Shajitha Begum. *Degree, Order and Size in Intuitionistic Fuzzy Graphs*, International Journal of Algorithms, Computing and Mathematics, (3)3 (2010).
- [4] F. Smarandache. *Refined Literal Indeterminacy and the Multiplication Law of Sub-Indeterminacies*, Neutrosophic Sets and Systems, Vol. 9, (2015) 58- 63.
- [5] F. Smarandache. *Types of Neutrosophic Graphs and neutrosophic Algebraic Structures together with their Applications in Technology*, seminar, Universitatea Transilvania din Brasov, Facultatea de Design de Produs si Mediu, Brasov, Romania 06 June 2015.
- [6] F. Smarandache. *Symbolic Neutrosophic Theory*, Europeanova, Brussels, (2015), 195 p.
- [7] F. Smarandache. *Neutrosophic set - a generalization of the intuitionistic fuzzy set*, Granular Computing, 2006 IEEE International Conference, (2006), pp. 38 - 42, DOI: 10.1109/GRC.2006.1635754.
- [8] F. Smarandache. *Neutrosophic overset, neutrosophic underset, Neutrosophic offset, Similarly for Neutrosophic Over-/Under-/OffLogic, Probability, and Statistic*, Pons Editions, Brussels, 2016, 170 p.
- [9] F. Smarandache. *Neutrosophy. Neutrosophic Probability, Set, and Logic*, ProQuest Information & Learning, Ann Arbor, Michigan, USA, 105 p., 1998; <http://fs.gallup.unm.edu/eBook-neutrosophics6.pdf> (last edition online).
- [10] H. Wang, F. Smarandache, Y. Zhang, R. Sunderraman. *Single valued Neutrosophic Sets*. In: Multispace and Multistructure, 4 (2010), pp. 410-413.
- [11] H. Wang, F. Smarandache, Zhang, Y.-Q., R. Sunderraman. *Interval Neutrosophic Sets and Logic: Theory and Applications in Computing*, Hexis, Phoenix, AZ, USA (2005).
- [12] I. Turksen. *Interval valued fuzzy sets based on normal forms*. In: Fuzzy Sets and Systems, vol. 20, (1986), pp. 191-210.
- [13] K. Atanassov. *Intuitionistic fuzzy sets*. In: Fuzzy Sets and Systems, vol. 20, (1986), pp. 87-96.
- [14] K. Atanassov, G. Gargov. *Interval valued intuitionistic fuzzy sets*. In: Fuzzy Sets and Systems, vol. 31 (1989), pp. 343-349.
- [15] L. Zadeh. *Fuzzy sets*. In: Informtion and Control, 8 (1965), pp. 338-353.
- [16] M. Akram, B. Davvaz. *Strong intuitionistic fuzzy graphs*, Filomat, vol. 26, no. 1 (2012), pp. 177-196.
- [17] M. Akram, W. A. Dudek. *Interval-valued fuzzy graphs*. In: Computers & Mathematics with Applications, vol. 61, no. 2 (2011), pp. 289-299.
- [18] M. Akram. *Interval-valued fuzzy line graphs*. In: Neural Computing and Applications, vol. 21 (2012) 145-150.
- [19] M. Akram, N. O. Alshehri, W. A. Dudek. *Certain Types of Interval-Valued Fuzzy Graphs*. In: Journal of Applied Mathematics, 2013, 11 pages, <http://dx.doi.org/10.1155/2013/857070>.
- [20] M. Akram, M. M. Yousaf, W. A. Dudek. *Self centered interval-valued fuzzy graphs*. In: Afrika Matematika, Volume 26, Issue 5, pp. 887-898 (2015).
- [21] P. Bhattacharya. *Some remarks on fuzzy graphs*. In: Pattern Recognition Letters 6 (1987) 297-302.

- [22] R. Parvathi, M. G. Karunambigai. *Intuitionistic Fuzzy Graphs*, Computational Intelligence, Theory and applications, International Conference in Germany, Sept 18 -20, 2006.
- [23] S. Broumi, M. Talea, A. Bakali, F. Smarandache. *Single Valued Neutrosophic Graphs*. In: Journal of New Theory, no. 10, 2016, pp. 86-101.
- [24] S. Broumi, M. Talea, F. Smarandache, A. Bakali. *Single Valued Neutrosophic Graphs: Degree, Order and Size*. IEEE International Conference on Fuzzy Systems (FUZZ), 2016, pp. 2444-2451.
- [25] S. Broumi, A. Bakali, M. Talea, F. Smarandache. *Isolated Single Valued Neutrosophic Graphs*. In: Neutrosophic Sets and Systems, Vol. 11, 2016, pp. 74-78.
- [26] S. Broumi, M. Talea, A. Bakali, F. Smarandache. *Interval Valued Neutrosophic Graphs*, SISOM & ACOUSTICS 2016, Bucharest 12-13 May, pp. 79-91.
- [27] S. Broumi, F. Smarandache, M. Talea, A. Bakali. *Decision-Making Method Based on the Interval Valued Neutrosophic Graph*. In: Future Technologie, 2016, IEEE, pp. 44-50.
- [28] S. Broumi, F. Smarandache, M. Talea, A. Bakali. *Operations on Interval Valued Neutrosophic Graphs*, chapter in *New Trends in Neutrosophic Theory and Applications*, by Florentin Smarandache and Surpati Pramanik (Editors), 2016, pp. 231-254. ISBN 978-1-59973-498-9.
- [29] S. Broumi, A. Bakali, M. Talea, F. Smarandache and M. Ali. *Shortest Path Problem under Bipolar Neutrosophic Setting*. In: Applied Mechanics and Materials, Vol. 859, 2016, pp 59-66.
- [30] S. Broumi, A. Bakali, M. Talea, F. Smarandache and L. Vladareanu. *Computation of Shortest Path Problem in a Network with SV-Trapezoidal Neutrosophic Numbers*, Proceedings of the 2016 International Conference on Advanced Mechatronic Systems, Melbourne, Australia, 2016, pp. 417-422.
- [31] S. Broumi, A. Bakali, M. Talea, F. Smarandache and L. Vladareanu. *Applying Dijkstra Algorithm for Solving Neutrosophic Shortest Path Problem*, Proceedings of the 2016 International Conference on Advanced Mechatronic Systems, Melbourne, Australia, November 30 - December 3, 2016, pp. 412-416.
- [32] S. Broumi, M. Talea, A. Bakali, F. Smarandache. *On Bipolar Single Valued Neutrosophic Graphs*. In: Journal of New Theory, no. 11, 2016, pp. 84-102.
- [33] S. Broumi, F. Smarandache, M. Talea and A. Bakali. *An Introduction to Bipolar Single Valued Neutrosophic Graph Theory*. In: Applied Mechanics and Materials, vol.841, 2016, pp.184-191.
- [34] S. N. Mishra and A. Pal. *Product of Interval Valued Intuitionistic fuzzy graph*, In: Annals of Pure and Applied Mathematics Vol. 5, No. 1 (2013) 37-46.
- [35] S. Rahurikar. *On Isolated Fuzzy Graph*. In: International Journal of Research in Engineering Technology and Management, 3 pages.
- [36] W. B. Vasantha Kandasamy, K. Ilanthenral, Florentin Smarandache. *Neutrosophic Graphs: A New Dimension to Graph Theory*, Kindle Edition, 2015.
- [37] More information on <http://fs.gallup.unm.edu/NSS/>.

- [38] R. Dhavaseelan, R. Vikramaprasad, V. Krishnaraj. *Certain Types of neutrosophic graphs*. In: International Journal of Mathematical Sciences & Applications, Vol. 5, No. 2, 2015, pp. 333-339.