

**Mridula Sarkar**  
**Tapan Kumar Roy**  
**Florentin Smarandache**

Neutrosophic  
Optimization  
and its Application  
on Structural Designs

Mridula Sarkar  
Tapan Kumar Roy  
Florentin Smarandache

**Neutrosophic Optimization  
and its Application on Structural Designs**

*Mridula Sarkar*  
*Tapan Kumar Roy*

Department of Mathematics, Indian Institute of  
Engineering Science and Technology, Shibpur, P.O-  
Botanic Garden, Howrah-711103, West Bengal, India.

*mridula.sarkar86@rediffmail.com*

*roy\_t\_k@yahoo.co.in*

*Florentin Smarandache*

Department of Mathematics, University of New Mexico,  
Gallup Campus, USA.

*smarand@unm.edu*

*Mridula Sarkar*  
*Tapan Kumar Roy*  
*Florentin Smarandache*

**Neutrosophic  
Optimization  
and its Application  
on Structural Designs**



Brussels, 2018

ISBN 978-1-59973-543-6



9 781599 735436 >

# CONTENTS

## Chapter-1

<b>Basic Notions and Neutrosophic Optimization.....</b>	<b>1</b>
1.1 Overview.....	1
1.2 Neutrosophic Set.....	2
1.3 Single Valued Neutrosophic Set.....	2
1.4 Complement of Neutrosophic Set.....	3
1.5 Containment.....	3
1.6 Equality of Two Neutrosophic Sets.....	4
1.7 Union of Neutrosophic Sets.....	4
1.8 Intersection of Neutrosophic Sets.....	4
1.9 Difference of two single valued Neutrosophic Set.....	5
1.10 Normal Neutrosophic Set.....	6
1.11 Convex Neutrosophic Set.....	6
1.12 Single Valued Neutrosophic Number(SVNN).....	6
1.13 Generalized Triangular Neutrosophic Number(GTNN).....	7
1.14 $(\alpha, \beta, \gamma)$ - Cut of Single Valued Triangular Neutrosophic Number(SVTNN).....	8
1.15 Ranking of Triangular Neutrosophic Number.....	8
1.16 Nearest Interval Approximation for Neutrosophic Number.....	11
1.17 Decision Making in Imprecise Environment.....	12
1.18 Single-Objective Neutrosophic Geometric Programming.....	13
1.19 Numerical Example of Neutrosophic Geometric Programming.....	15
1.20 Application of Neutrosophic Geometric Programming in Gravel Box Design Problem.....	17
1.21 Multi-Objective Neutrosophic Geometric Programming Problem.....	18
1.22 Definition: Neutrosophic Pareto(or NS Pareto) Optimal Solution.....	22
1.23 Theorem 1.....	22
1.24 Theorem 2.....	23
1.25 Illustrated Numerical Example.....	24
1.26 Application of Neutrosophic Optimization in Gravel Box Design Problem.....	26
1.27 Multi-Objective Neutrosophic Linear Programming Problem (MOLPP).....	27
1.28 Production Planning Problem.....	39
1.29 Neutrosophic Optimization (NSO)Technique to two type Single-Objective Minimization Type Nonlinear Programming (SONLP)Problem.....	42
1.30 Neutrosophic Optimization Technique to solve Minimization Type Multi Objective Non-linear Programming Problem for Linear Membership Function...55	55
1.31 Illustrated Numerical Example.....	63
1.32 Application of Neutrosophic Optimization in Riser Design Problem.....	63
1.33 Neutrosophic Optimization(NSO) Technique to Solve Minimization Type Multi Objective Non-linear Programming Problem(MONLP).....	65
1.34 Neutrosophic Goal Programming(NGP).....	74
1.35 Theorem on Generalized Goal Programming.....	76

1.36	Generalized Neutrosophic Goal Programming(GNGP).....	78
1.37	Application of Neutrosophic Goal Programming to Bank Three Investment Problem.....	80
1.38	Numerical Example.....	82
1.39	Neutrosophic Non-linear Programming (NNLP) Optimization to solve Parameterized Multi-objective Non-linear Programming Problem (PMONLP)...	83
1.40	Neutrosophic Optimization Technique(NSO) to solve Parametric Single-Objective Non-linear Programming Problem (PSOONLP).....	88
<b>Chapter-2</b>	<b>Structural Design Optimization.....</b>	<b>94</b>
2.1	S.I Unit Prefixes .....	96
2.2	Conversion of U.S Customary Units to S.I Units.....	96
2.3	Design Studies.....	97
2.3.1	Two-Bar Truss(Model-I).....	97
2.3.2	Three-Bar Truss(Model-II).....	99
2.3.3	Design Criteria for Thickness Optimization.....	104
2.3.4	Welded Beam Design Formulation.....	109
<b>Chapter-3</b>	<b>Truss Design Optimization using Neutrosophic Optimization Technique: A Comparative Study.....</b>	<b>115</b>
3.1	General Formulation of Single-objective Structural Model.....	116
3.2	Neutrosophic Optimization Technique to Solve Single-objective Structural Optimization Problem (SOSOP).....	117
3.3	Numerical Solution of Two Bar Truss Design using Single Objective NSO Technique.....	128
3.4	Conclusion.....	136
<b>Chapter-4</b>	<b>Multi-Objective Neutrosophic Optimization Technique and its Application to Structural.....</b>	<b>138</b>
4.1	General form of Multi-Objective Truss Design Model.....	139
4.2	Solution of Multi-objective Structural Optimization Problem (MOSOP) by Neutrosophic Optimization Technique.....	140
4.3	Numerical Solution of Solution of Multi-objective Structural Optimization Problem (MOSOP) by Neutrosophic Optimization Technique.....	147
4.4	Conclusion .....	155
<b>Chapter-5</b>	<b>Optimization of Welded Beam Structure using Neutrosophic Optimization Technique: A Comparative Study.....</b>	<b>156</b>
5.1	Welded Beam Design (WBD)and its Optimization in Neutrosophic Environment.....	158

5.2.1	Crisp Formulation of WBD.....	159
5.2.2	WBD Formulation in Neutrosophic Environment.....	161
5.2.3	Optimization of WBD in Neutrosophic Environment.....	162
5.2	Numerical Solution of WBD by Single Objective Neutrosophic Optimization Technique.....	167
5.3	Conclusion.....	173
<b>Chapter-6</b>	<b>Multi-Objective Welded Beam Optimization using Neutrosophic Optimization Technique: A Comparative Study.....</b>	<b>175</b>
6.1	General Form of Multi-Objective Welded Beam Design(MOWBD).....	176
6.2	Solution of Multi-Objective Welded Beam Design (MOWBD) Problem by Neutrosophic Optimization(NSO) Technique.....	177
6.3	Numerical Solution of Welded Beam Design using Multi-Objective Neutrosophic Optimization Technique.....	185
6.4	Conclusion.....	197
<b>Chapter-7</b>	<b>Multi-Objective Welded Beam Optimization using Neutrosophic Goal Programming Technique.....</b>	<b>198</b>
7.1	General Formulation of Multi-objective Welded Beam Design.....	200
7.2	Generalized Neutrosophic Goal Optimization Technique to Solve Multi- objective Welded Beam Optimization Problem (MOWBP).....	201
7.3	Numerical Solution of Welded Beam Design by GNGP, based on Different Operator.....	204
7.4	Conclusion.....	211
<b>Chapter-8</b>	<b>Truss Design Optimization with Imprecise Load and Stress in Neutrosophic Environment.....</b>	<b>212</b>
8.1	Multi-Objective Structural Design Formulation.....	213
8.2	Parametric Neutrosophic Optimization Technique to Solve Multi-Objective Structural Optimization Problem.....	214
8.3	Numerical Solution of Three Bar Truss Design using Parametric Neutrosophic Optimization Technique.....	218
8.4	Conclusion.....	227
<b>Chapter-9</b>	<b>Optimization of Welded Beam with Imprecise Load and Stress by Parameterized Neutrosophic Optimization Technique.....</b>	<b>229</b>
9.1	General Formulation of Single-Objective Welded Beam Design.....	230
9.2	NSO Technique to Optimize Parametric Single-Objective Welded Beam Design(SOWBD).....	231
9.3	Numerical Solution of Parametric Welded Beam Design Problem by NSO Technique.....	234
9.4	Conclusion.....	242
<b>Chapter-10</b>	<b>Optimization of Thickness of Jointed Plain Concrete Pavement Using Neutrosophic Optimization Technique.....</b>	<b>243</b>
10.1	Formulation for Optimum JPCP Design.....	244



10.1.1	Design input parameters.....	245
10.1.2	Design method.....	245
10.2	Neutrosophic Optimization.....	248
10.3	Numerical Illustration of Optimum JPCP Design based on IRC:58-2002....	251
10.4	Conclusion.....	254

**Chapter-11 Multi-Objective Structural Design Optimization Based on Neutrosophic**

<b>Goal Programming Technique.....</b>	<b>256</b>	
11.1	Multi-Objective Structural Model.....	257
11.2	Solution of Multi-objective Structural Optimization Problem (MOSOP) by Generalized Neutrosophic Goal Optimization Technique.....	258
11.3	Numerical Illustration.....	261
11.4	Conclusion.....	267

**Chapter-12 Multi-objective Cylindrical Skin Plate Design Optimization based on Neutrosophic Optimization Technique.....**

<b>269</b>		
12.1	Multi-Objective Structural Model Formulation.....	270
12.2	Solution of Multi-objective Structural Optimization Problem (MOSOP) by Neutrosophic Optimization Technique.....	270
12.3	Numerical Illustration.....	271
12.4	Conclusion.....	274

**Chapter-13 APPENDIX-A.....**

<b>275</b>		
13.1	Crisp Set.....	275
13.2	Fuzzy Set.....	275
13.3	Height of a Fuzzy Set.....	276
13.4	Normal Fuzzy Set.....	276
13.5	$\alpha$ – Cut of Fuzzy Set.....	276
13.6	Union of Two Fuzzy Sets.....	276
13.7	Intersection of Two Fuzzy Sets.....	276
13.8	Convex Fuzzy Set.....	277
13.9	Interval Number.....	277
13.10	Fuzzy Number.....	277
13.10.1	Trapezoidal Fuzzy Number(TrFN).....	279
13.11	$\alpha$ – Cut of Fuzzy Number.....	279
13.12	Generalized Fuzzy Number (GFN).....	280
13.13	Nearest Interval Approximation of Fuzzy Number.....	281
13.14	Intuitionistic Fuzzy Set.....	282
13.15	$(\alpha, \beta)$ – Level Or $(\alpha, \beta)$ – Cuts.....	283
13.16	Convex Intuitionistic Fuzzy Set.....	283
13.17	Union of Two Intuitionistic Fuzzy Sets.....	284

13.18	Intersection of Two Intuitionistic Fuzzy Sets.....	284
13.19	Generalized Intuitionistic Fuzzy Number(GIFN).....	284
13.20	Generalized Triangular Intuitionistic Fuzzy Number(GTIFN).....	284
13.21	$\alpha$ -Level Set or $\alpha$ - Cut of Intuitionistic Fuzzy Number.....	285
13.22	Arithmetic Operation of Triangular Intuitionistic Fuzzy Number (TIFN).....	285
13.23	Nearest Interval Approximation for Intuitionistic Fuzzy Number.....	286
13.24	Parametric Interval Valued Function.....	287
13.25	Ranking of Triangular Intuitionistic Fuzzy Number.....	288

<b>Chapter-14</b>	<b>APPENDIX-B.....</b>	<b>290</b>
14.1	Geometric Programming(GP) Method.....	290
14.2	Posynomial Geometric Programming Problem.....	291
14.3	Signomial Geometric Programming Problem.....	292
14.4	Fuzzy Geometric Programming (FGP) .....	293
14.5	Numerical Example of Fuzzy Geometric Programming.....	295
14.6	Intuitionistic Fuzzy Geometric Programming.....	297
14.7	Fuzzy Decision Making.....	301
14.8	Additive Fuzzy Decision.....	301
14.9	Intuitionistic Fuzzy Optimization(IFO) Technique to solve Minimization Type Single Objective Non-linear Programming (SONLP) Problem .....	302
14.10	Fuzzy Non-linear Programming (FNLP) Technique to Solve Multi-Objective Non Linear Programming (MONLP) problem.....	306
14.11	An Intuitionistic Fuzzy(IF) Approach for Solving Multi-Objective Non-Linear Programming(MONLP) Problem with Non-linear membership and Non-linear Non-membership Function.....	308
14.12	Intuitionistic Fuzzy Non-linear Programming (IFNLP) Optimization to solve Parametric Multi-Objective Non-linear Programming Problem (PMONLP).....	311
14.13	Fuzzy and Intuitionistic Fuzzy Non-linear Programming (IFNLP) Optimization to solve Parametric Single-Objective Non-linear Programming (PSONLP) Problem.....	316
	<b>Bibliography.....</b>	<b>322</b>

# PREFACE

In the real world, uncertainty or vagueness is prevalent in engineering and management computations. Commonly, such uncertainties are included in the design process by introducing simplified hypothesis and safety or design factors. In case of structural and pavement design, several design methods are available to optimize objectives. But all such methods follow numerous monographs, tables and charts to find effective thickness of pavement design or optimum weight and deflection of structure calculating certain loop of algorithm in the cited iteration process. Most of the time, designers either only take help of a software or stop the cited procedure even after two or three iterations. As for example, the finite element method and genetic algorithm type of crisp optimization method had been applied on the cited topic, where the values of the input parameters were obtained from experimental data in laboratory scale. But practically, above cited standards have already ranged the magnitude of those parameters in between maximum to the minimum values. As such, the designer becomes puzzled to select those input parameters from such ranges which actually yield imprecise parameters or goals with three key governing factors i.e. degrees of acceptance, rejection and hesitancy, requiring fuzzy, intuitionistic fuzzy, and neutrosophic optimization.

Therefore, the problem of structural designs, pavement designs, welded beam designs are firstly classified into single objective and multi-objective problems of structural systems. Then, a mathematical algorithm - e.g. Neutrosophic Geometric Programming, Neutrosophic Linear Programming Problem, Single Objective Neutrosophic Optimization, Multi-objective Neutrosophic Optimization, Parameterized Neutrosophic Optimization, Neutrosophic Goal Programming Technique - has been provided to solve the problem according to the nature of impreciseness that exists in the problem.

Thus, we provide in this book a solution which is hardly presented in the scientific literature regarding structural optimum design, pavement optimum design, welded beam optimum design, that works in imprecise environment i.e. in neutrosophic environment.

The objective of the book is not only to study the concept of neutrosophic set, single valued neutrosophic set, complement of neutrosophic set, union of neutrosophic set, intersection of neutrosophic set, generalized fuzzy number, triangular fuzzy number, normal neutrosophic

set, convex neutrosophic set, single valued neutrosophic number, generalized triangular neutrosophic number and their properties, but also to fulfil the criteria of specification of such concepts from a technical point of view. The second objective of the book is the identification of impreciseness that is involved in real life engineering design problems, such as in various structural design problems, welded beam designs and pavement designs problems. For example, they are often exhibit in the form of applied load, stresses, deflection in the test problem, therefore we employ ultimate development of mathematical algorithm using neutrosophic set theory to optimize various truss, welded beam, pavement design problems in neutrosophic environment.

In the following chapters, some mathematical optimization methods on neutrosophic set theory have been studied and the results have been compared against Fuzzy and Intuitionistic Fuzzy Optimization methods. Some structural models like two-bar, three bar truss, welded beam design, jointed plain concrete pavement are formulated and solved in fuzzy, intuitionistic fuzzy or neutrosophic environments. The proposed thesis has been divided into following chapters:

In the **First chapter**, the basic concepts and definitions of Neutrosophic set, Single Valued Neutrosophic Set (SVNS), complement of Neutrosophic Set, union of Neutrosophic Set, intersection of Neutrosophic Set, Normal Neutrosophic Set, Convex Neutrosophic Set, Single Valued Neutrosophic Number (SVNN), Generalized Triangular Neutrosophic Number (GTNN) are given. Also, in this chapter, some basic methodologies - such as neutrosophic linear programming, neutrosophic geometric programming, neutrosophic optimization technique to solve minimization type single objective nonlinear programming problem, neutrosophic optimization technique to solve minimization type nonlinear programming problem, solution of multi-objective welded beam optimization problem by generalized neutrosophic goal programming technique, neutrosophic non-linear programming optimization to solve parameterized multi-objective nonlinear programming problem, neutrosophic optimization technique to solve parametric single objective nonlinear programming problem - have been discussed to solve several trusses, welded beam optimum and jointed plain concrete pavement designs.

In the **Second chapter**, an introduction of structural design optimization, conversion between U.S customary units and S.I units, S.I. unit prefixes, formulation of truss design, some welded beam designs and pavement designs are presented.

In the **Third Chapter**, we take into consideration a neutrosophic optimization (NSO) approach for optimizing the design of truss with single objective, subject to a specified set of constraints.

In the **Fourth chapter**, a multi-objective non-linear neutrosophic optimization (NSO) approach for optimizing the design of plane truss structure with multiple objectives subject to a specified set of constraints is explained.

In the **Fifth chapter**, a Neutrosophic Optimization (NSO) approach is investigated to optimize the cost of welding of a welded steel beam, where the maximum shear stress in the weld group, maximum bending stress in the beam, maximum deflection at the tip and buckling load of the beam are considered as flexible constraints.

In the **Sixth chapter**, a multi-objective Neutrosophic Optimization (NSO) approach is studied to optimize the cost of welding and deflection at the tip of a welded steel beam.

In the **Seventh chapter**, a multi-objective Neutrosophic Goal Optimization (NSGO) approach with different aggregation method is explored to optimize the cost of welding and deflection at the tip of a welded steel beam, while the maximum shear stress in the weld group, maximum bending stress in the beam, and buckling load of the beam are considered as constraints.

In the **Eighth Chapter**, we employ a neutrosophic mathematical programming to solve a multi-objective structural optimization problem with imprecise parameters. Generalized Single Valued Triangular Neutrosophic Numbers (GSVNNs) are assumed imprecise loads and stresses in a test problem.

In the **Ninth chapter**, a solution procedure of Neutrosophic Optimization (NSO) is examined to solve optimum welded beam design with inexact co-efficient and resources. Interval approximation method is used here to convert the imprecise co-efficient, which is a triangular neutrosophic number, to an interval number.

In the **Tenth chapter**, the optimization of thickness of Jointed Plain Concrete Pavement (JPCP) by following the guidelines of Indian Roads Congress (IRC:58- 2002) in imprecise environment is studied and solved by neutrosophic optimization technique.

In the **Eleventh Chapter**, we analyze a multi-objective Neutrosophic Goal Optimization (NSGO) technique for optimizing the design of three bar truss structure with multiple objectives, subject to a specified set of constraints.

In the **Twelfth Chapter**, we search upon a Neutrosophic Optimization (NSO) approach for optimizing the thickness and sag of skin plate of vertical lift gate with multi- objective, subject to a specified constraint.

*The Authors*

# CHAPTER 1

---

## Basic Notions and Neutrosophic Optimization

---

### 1.1 Overview

The concept of fuzzy set was introduced by Zadeh in 1965. Since the fuzzy sets and fuzzy logic have been applied in many real applications to handle uncertainty. The traditional fuzzy set uses only real value  $\mu_{\tilde{A}}(x) \in [0,1]$  to represent the grade of membership of fuzzy set  $\tilde{A}$  defined on universe  $X$ . Sometimes  $\mu_{\tilde{A}}(x)$  itself is uncertain and hard to be defined by a crisp value. So the concept of interval valued fuzzy sets was proposed to capture the uncertainty of grade of membership. Interval valued fuzzy sets uses an interval value  $[\mu_{\tilde{A}}^L(x), \mu_{\tilde{A}}^U(x)]$  with  $0 \leq \mu_{\tilde{A}}^L(x) \leq \mu_{\tilde{A}}^U(x) \leq 1$  to represent the grade of membership of fuzzy set  $\tilde{A}$ . In some applications such as expert system, belief system and information fusion, we should consider not only the truth membership supported by the evident but also the falsity membership against by the evident. That is beyond the scope of fuzzy sets and interval valued fuzzy sets. In 1986 Atanassov introduced the Intuitionistic fuzzy sets which is a generalization of fuzzy sets and probably equivalent to interval valued fuzzy sets. The intuitionistic fuzzy sets consider both truth membership  $T_{\tilde{A}}(x)$  and falsity membership  $F_{\tilde{A}}(x)$  with  $T_{\tilde{A}}(x), F_{\tilde{A}}(x) \in [0,1]$  and  $0 \leq T_{\tilde{A}}(x) + F_{\tilde{A}}(x) \leq 1$ . Intuitionistic fuzzy sets can only handle incomplete information not the indeterminate information and inconsistent information which exists commonly belief in system. In intuitionistic fuzzy sets, indeterminacy is  $1 - T_{\tilde{A}}(x) - F_{\tilde{A}}(x)$  by default. For example when we ask the opinion of expert about certain statement, he or she may be in the position of the possibility that the statement is true is 0.5 and the statement is false is 0.6 and the degree that he or she is not sure is 0.2.

In neutrosophic set indeterminacy is quantified explicitly and truth membership, indeterminacy membership and falsity membership are independent. This assumption is very important in a lot of situations such as information fusion when we try to combine the data from different sensors. Neutrosophy was introduced by Smarandache in 1995. "It is a branch of philosophy which studies the origin, nature and scope of neutralities, as well as their

interactions with different ideational spectra". Neutrosophic Set is a power general framework which generalizes the concept of the classic set, fuzzy set, interval valued fuzzy set, intuitionistic fuzzy set e.t.c. A neutrosophic set  $\tilde{A}^n$  defined on universe  $U$ .  $x = x(T, I, F) \in \tilde{A}^n$  with  $T, I, F$  being real standard or nonstandard subset of  $]0^-, 1^+[$ .  $T$  is the degree truth membership function in the set  $\tilde{A}^n$ ,  $I$  is the degree indeterminacy membership function in the set  $\tilde{A}^n$  and  $F$  is the degree falsity membership function in the set  $\tilde{A}^n$ .

The neutrosophic set generalizes the above mentioned sets from philosophical point of view. From scientific or engineering point of view the neutrosophic set and set theoretic operators need to be specified. Otherwise, it will be difficult to apply in the real applications. In this paper, we define neutrosophic set (the set theoretic operators on an instance of neutrosophic set called SVNS).

## 1.2 Neutrosophic Set (NS)

Let  $X$  be a space of points (objects) with a generic element in  $X$  denoted by  $x$  i.e.  $x \in X$ . A neutrosophic set  $\tilde{A}^n$  in  $X$  is characterized by truth-membership function  $T_{\tilde{A}^n}$ , indeterminacy-membership function  $I_{\tilde{A}^n}$  and falsity-membership function  $F_{\tilde{A}^n}$ , where  $T_{\tilde{A}^n}, I_{\tilde{A}^n}, F_{\tilde{A}^n}$  are the functions from  $U$  to  $]0^-, 1^+[$  i.e.  $T_{\tilde{A}^n}, I_{\tilde{A}^n}, F_{\tilde{A}^n} : X \rightarrow ]0^-, 1^+[$ , that means  $T_{\tilde{A}^n}, I_{\tilde{A}^n}, F_{\tilde{A}^n}$  are the real standard or non-standard subset of  $]0^-, 1^+[$ . Neutrosophic set can be expressed as  $\tilde{A}^n = \{ \langle x, (T_{\tilde{A}^n}, I_{\tilde{A}^n}, F_{\tilde{A}^n}) \rangle : \forall x \in X \}$ . Since  $T_{\tilde{A}^n}, I_{\tilde{A}^n}, F_{\tilde{A}^n}$  are the subset of  $]0^-, 1^+[$ , there the sum

$(T_{\tilde{A}^n}, I_{\tilde{A}^n}, F_{\tilde{A}^n})$  lies between  $^-0$  and  $3^+$ , where  $^-0 = 0 - \varepsilon$  and  $3^+ = 3 + \varepsilon$ ,  $\varepsilon > 0$ .

The set  $I_{\tilde{A}^n}$  may represent not only indeterminacy, but also vagueness, uncertainty, imprecision, error, contradiction, undefined, unknown, incompleteness, redundancy, etc. In order to catch up vague information, an indeterminacy-membership degree can be split into subcomponents, such as „contradiction“, „uncertainty“, and „unknown“.

### Example 1.

Suppose that  $X = \{x_1, x_2, x_3, \dots\}$ . be the universal set. Let  $\tilde{A}_1$  be any neutrosophic set in  $X$ . Then  $\tilde{A}_1$  expressed as  $\tilde{A}_1 = \{ \langle x_1 : (.6, .3, .4) \rangle : x_1 \in X \}$ .



### 1.3 Single Valued Neutrosophic Set (SVNS)

Let a set  $X$  be the universe of discourse. A single valued neutrosophic set  $\tilde{A}^n$  over  $X$  is an object having the form  $\tilde{A}^n = \{ \langle x, T_{\tilde{A}^n}(x), I_{\tilde{A}^n}(x), F_{\tilde{A}^n}(x) \rangle \mid x \in X \}$  where  $T_{\tilde{A}^n} : X \rightarrow [0,1]$ ,  $I_{\tilde{A}^n} : X \rightarrow [0,1]$  and  $F_{\tilde{A}^n} : X \rightarrow [0,1]$  are truth, indeterminacy and falsity membership functions with  $0 \leq T_{\tilde{A}^n}(x) + I_{\tilde{A}^n}(x) + F_{\tilde{A}^n}(x) \leq 3$  for all  $x \in X$ .

**Example 1:** Assume that  $X = [x_1, x_2, x_3]$ .  $x_1$  is capability,  $x_2$  is trustworthiness and  $x_3$  is price. The values of  $x_1, x_2, x_3$  are in  $[0,1]$ . They are obtained from questionnaire of some domain experts, their option could be a degree of “good service”, a degree of indeterminacy and degree of “poor service”.  $\tilde{A}^n$  is a single valued neutrosophic set of  $X$  defined by  $\tilde{A}^n = \langle 0.3, 0.4, 0.5 \rangle / x_1 + \langle 0.5, 0.2, 0.3 \rangle / x_2 + \langle 0.7, 0.2, 0.2 \rangle / x_3$ .  $\tilde{B}^n$  is a single valued neutrosophic set of  $X$  defined by  $\tilde{B}^n = \langle 0.6, 0.1, 0.2 \rangle / x_1 + \langle 0.3, 0.2, 0.6 \rangle / x_2 + \langle 0.4, 0.1, 0.5 \rangle / x_3$ .

### 1.4 Complement of Neutrosophic Set

Complement of a single valued neutrosophic set  $\tilde{A}^n$  is denoted by  $C(\tilde{A}^n)$  and its truth, indeterminacy and falsity membership functions are denoted by  $T_{C(\tilde{A}^n)} : X \rightarrow [0,1]$ ,  $I_{C(\tilde{A}^n)} : X \rightarrow [0,1]$  and  $F_{C(\tilde{A}^n)} : X \rightarrow [0,1]$  where

$$T_{C(\tilde{A}^n)}(x) = F_{\tilde{A}^n}(x), \quad (1.2)$$

$$I_{C(\tilde{A}^n)}(x) = 1 - I_{\tilde{A}^n}(x), \quad (1.3)$$

$$F_{C(\tilde{A}^n)}(x) = T_{\tilde{A}^n}(x). \quad (1.4)$$

**Example 2:** Let  $\tilde{A}^n$  be a single valued neutrosophic set in Example 1. Then  $C(\tilde{A}^n) = \langle 0.5, 0.6, 0.3 \rangle / x_1 + \langle 0.3, 0.8, 0.5 \rangle / x_2 + \langle 0.2, 0.8, 0.7 \rangle / x_3$

### 1.5 Containment

A single valued neutrosophic set  $\tilde{A}^n$  is contained in other single valued neutrosophic set  $\tilde{B}^n$ ,

$\tilde{A}^n \subseteq \tilde{B}^n$  if and only if

$$T_{\tilde{A}^n}(x) \leq T_{\tilde{B}^n}(x)$$

$$I_{\tilde{A}^n}(x) \leq I_{\tilde{B}^n}(x)$$

$$F_{\tilde{A}^n}(x) \leq F_{\tilde{B}^n}(x)$$

For all  $x$  in  $X$ .

Note that by definition of containment,  $X$  is partial order but not linear order. For example let  $\tilde{A}^n$  and  $\tilde{B}^n$  be the single valued neutrosophic sets defined in example 1. Then  $\tilde{A}^n$  is not contained in  $\tilde{B}^n$  and  $\tilde{B}^n$  is not contained in  $\tilde{A}^n$

## 1.6 Equality of Two Neutrosophic Sets

Two single valued neutrosophic sets  $\tilde{A}^n$  and  $\tilde{B}^n$  are said to be equal and written as  $\tilde{A}^n = \tilde{B}^n$  if and only if  $\tilde{A}^n \subseteq \tilde{B}^n$  and  $\tilde{A}^n \supseteq \tilde{B}^n$

## 1.7 Union of Neutrosophic Sets

The union of two single valued neutrosophic sets  $\tilde{A}^n$  and  $\tilde{B}^n$  is a single valued neutrosophic set  $\tilde{U}^n$ , written as  $\tilde{U}^n = \tilde{A}^n \cup \tilde{B}^n$ , whose truth membership, indeterminacy-membership and falsity-membership functions are given by

### Type-I

- (i)  $T_{\tilde{U}^n}(x) = \max(T_{\tilde{A}^n}(x), T_{\tilde{B}^n}(x))$ ,
- (ii)  $I_{\tilde{U}^n}(x) = \max(I_{\tilde{A}^n}(x), I_{\tilde{B}^n}(x))$
- (iii)  $F_{\tilde{U}^n}(x) = \min(F_{\tilde{A}^n}(x), F_{\tilde{B}^n}(x))$  for all  $x \in X$

### Type-II

- (i)  $T_{\tilde{U}^n}(x) = \max(T_{\tilde{A}^n}(x), T_{\tilde{B}^n}(x))$ ,
- (ii)  $I_{\tilde{U}^n}(x) = \min(I_{\tilde{A}^n}(x), I_{\tilde{B}^n}(x))$
- (iii)  $F_{\tilde{U}^n}(x) = \min(F_{\tilde{A}^n}(x), F_{\tilde{B}^n}(x))$  for all  $x \in X$

### Example 3:

Let  $\tilde{A}^n = \langle 0.3, 0.4, 0.5 \rangle / x_1 + \langle 0.5, 0.2, 0.3 \rangle / x_2 + \langle 0.7, 0.2, 0.2 \rangle / x_3$  and

$\tilde{B}^n = \langle 0.6, 0.1, 0.2 \rangle / x_1 + \langle 0.3, 0.2, 0.6 \rangle / x_2 + \langle 0.4, 0.1, 0.5 \rangle / x_3$  be two neutrosophic sets. Then the union of  $\tilde{A}^n$  and  $\tilde{B}^n$  is a single valued neutrosophic set

### Type -I

$$\tilde{A}^n \cup \tilde{B}^n = \langle 0.6, 0.4, 0.2 \rangle / x_1 + \langle 0.5, 0.2, 0.3 \rangle / x_2 + \langle 0.7, 0.2, 0.2 \rangle / x_3$$

### Type -II

$$\tilde{A}^n \cup \tilde{B}^n = \langle 0.6, 0.1, 0.2 \rangle / x_1 + \langle 0.5, 0.2, 0.3 \rangle / x_2 + \langle 0.7, 0.1, 0.2 \rangle / x_3$$

## 1.8 Intersection of Neutrosophic Sets

The intersection of two single valued neutrosophic sets  $\tilde{A}^n$  and  $\tilde{B}^n$  is a single valued neutrosophic set  $\tilde{E}^n$ , written as  $\tilde{E}^n = \tilde{A}^n \cap \tilde{B}^n$ , whose truth membership, indeterminacy-membership and falsity-membership functions are given by

**Type-I**

- (i)  $T_{\tilde{E}^n}(x) = \min(T_{\tilde{A}^n}(x), T_{\tilde{B}^n}(x))$ ,
- (ii)  $I_{\tilde{E}^n}(x) = \min(I_{\tilde{A}^n}(x), I_{\tilde{B}^n}(x))$
- (iii)  $F_{\tilde{E}^n}(x) = \max(F_{\tilde{A}^n}(x), F_{\tilde{B}^n}(x))$  for all  $x \in X$

**Type-II**

- (i)  $T_{\tilde{E}^n}(x) = \min(T_{\tilde{A}^n}(x), T_{\tilde{B}^n}(x))$ ,
- (ii)  $I_{\tilde{E}^n}(x) = \max(I_{\tilde{A}^n}(x), I_{\tilde{B}^n}(x))$
- (iii)  $F_{\tilde{E}^n}(x) = \max(F_{\tilde{A}^n}(x), F_{\tilde{B}^n}(x))$  for all  $x \in X$

**Example 4:**

Let  $\tilde{A}^n = \langle 0.3, 0.4, 0.5 \rangle / x_1 + \langle 0.5, 0.2, 0.3 \rangle / x_2 + \langle 0.7, 0.2, 0.2 \rangle / x_3$  and

$\tilde{B}^n = \langle 0.6, 0.1, 0.2 \rangle / x_1 + \langle 0.3, 0.2, 0.6 \rangle / x_2 + \langle 0.4, 0.1, 0.5 \rangle / x_3$  be two neutrosophic sets. Then the union of  $\tilde{A}^n$  and  $\tilde{B}^n$  is a single valued neutrosophic set

**Type -I**

$$\tilde{A}^n \cap \tilde{B}^n = \langle 0.3, 0.1, 0.5 \rangle / x_1 + \langle 0.3, 0.2, 0.6 \rangle / x_2 + \langle 0.4, 0.1, 0.5 \rangle / x_3$$

**Type -II**

$$\tilde{A}^n \cap \tilde{B}^n = \langle 0.3, 0.4, 0.5 \rangle / x_1 + \langle 0.3, 0.2, 0.6 \rangle / x_2 + \langle 0.4, 0.2, 0.5 \rangle / x_3$$

**1.9 Difference of Two Single Valued Neutrosophic set**

The difference of two single valued neutrosophic set  $\tilde{D}^n$ , written as  $\tilde{D}^n = \tilde{A}^n / \tilde{B}^n$ , whose truth-membership, indeterminacy membership and falsity membership functions are related to those of  $\tilde{A}^n$  and  $\tilde{B}^n$  can be defined by

- (i)  $T_{\tilde{D}^n}(x) = \min(T_{\tilde{A}^n}(x), T_{\tilde{B}^n}(x))$ ,
- (ii)  $I_{\tilde{D}^n}(x) = \min(I_{\tilde{A}^n}(x), 1 - I_{\tilde{B}^n}(x))$
- (iii)  $F_{\tilde{D}^n}(x) = \max(F_{\tilde{A}^n}(x), F_{\tilde{B}^n}(x))$  for all  $x \in X$

**Example 5:** Let  $\tilde{A}^n$  and  $\tilde{B}^n$  be a single valued neutrosophic set in Example 1. Then

$$\tilde{D}^n = \langle 0.2, 0.4, 0.6 \rangle / x_1 + \langle 0.5, 0.2, 0.3 \rangle / x_2 + \langle 0.5, 0.2, 0.4 \rangle / x_3$$

### 1.10 Normal Neutrosophic Set

A single valued neutrosophic set  $\tilde{A}^n = \{ \langle x, T_{\tilde{A}^n}(x), I_{\tilde{A}^n}(x), F_{\tilde{A}^n}(x) \rangle | x \in X \}$  is called neutrosophic normal if there exists at least three points  $x_0, x_1, x_2 \in X$  such that  $T_{\tilde{A}^n}(x_0) = 1$ ,  $I_{\tilde{A}^n}(x_1) = 1$ ,  $F_{\tilde{A}^n}(x_2) = 1$ .

### 1.11 Convex Neutrosophic Set

A single valued neutrosophic set  $\tilde{A}^n = \{ \langle x, T_{\tilde{A}^n}(x), I_{\tilde{A}^n}(x), F_{\tilde{A}^n}(x) \rangle | x \in X \}$  is a subset of the real line called neut-convex if for all  $x_1, x_2 \in \mathfrak{R}$  and  $\lambda \in [0, 1]$  the following conditions are satisfied.

1.  $T_{\tilde{A}^n} \{ \lambda x_1 + (1 - \lambda) x_2 \} \geq \min \{ T_{\tilde{A}^n}(x_1), T_{\tilde{A}^n}(x_2) \}$
2.  $I_{\tilde{A}^n} \{ \lambda x_1 + (1 - \lambda) x_2 \} \leq \max \{ I_{\tilde{A}^n}(x_1), I_{\tilde{A}^n}(x_2) \}$
3.  $F_{\tilde{A}^n} \{ \lambda x_1 + (1 - \lambda) x_2 \} \leq \max \{ F_{\tilde{A}^n}(x_1), F_{\tilde{A}^n}(x_2) \}$

i.e.  $\tilde{A}^n$  is neut-convex if its truth membership function is fuzzy convex, indeterminacy membership function is fuzzy concave and falsity membership function is fuzzy concave.

### 1.12 Single Valued Neutrosophic Number(SVNN)

A single valued neutrosophic set  $\tilde{A}^n = \{ \langle x, T_{\tilde{A}^n}(x), I_{\tilde{A}^n}(x), F_{\tilde{A}^n}(x) \rangle | x \in X \}$ , subset of a real line, is called generalised neutrosophic number if

1.  $\tilde{A}^n$  is neut-normal.
2.  $\tilde{A}^n$  is neut-convex.
3.  $T_{\tilde{A}^n}(x)$  is upper semi-continuous,  $I_{\tilde{A}^n}(x)$  is lower semi continuous and  $F_{\tilde{A}^n}(x)$  is lower semi continuous, and
4. the support of  $\tilde{A}^n$ , i.e.

$$S(\tilde{A}^n) = \{ x \in X : T_{\tilde{A}^n} > 0, I_{\tilde{A}^n} < 1, F_{\tilde{A}^n} < 1 \} \quad (1.5)$$

is bounded.

Thus for any Single Valued Triangular Neutrosophic Number (TNN) there exists nine numbers  $a_1^T, a_2, a_3^T, b_1^I, b_2, b_3^I, c_1^F, c_2, c_3^F \in \mathfrak{R}$  such that  $c_1^F \leq b_1^I \leq a_1^T \leq c_2 \leq b_2 \leq a_2 \leq a_3^T \leq b_3^I \leq c_3^F$

and six functions  $T_{\tilde{A}^n}^L(x), I_{\tilde{A}^n}^L(x), F_{\tilde{A}^n}^L(x), T_{\tilde{A}^n}^R(x), I_{\tilde{A}^n}^R(x), F_{\tilde{A}^n}^R(x): \mathfrak{R} \rightarrow [0,1]$  represent truth, indeterminacy and falsity membership degree of  $\tilde{A}^n$ . The three non-decreasing functions  $T_{\tilde{A}^n}^L(x), I_{\tilde{A}^n}^L(x), F_{\tilde{A}^n}^L(x)$  represent the left side of truth, indeterminacy and falsity membership functions of SVN  $\tilde{A}^n$  respectively. Similarly the three non-increasing functions  $T_{\tilde{A}^n}^R(x), I_{\tilde{A}^n}^R(x), F_{\tilde{A}^n}^R(x)$  represent the right side of truth, indeterminacy and falsity membership functions of SVN  $\tilde{A}^n$  respectively. The truth, indeterminacy and falsity membership functions of SVN  $\tilde{A}^n$  can be defined in the following way

$$T_{\tilde{A}^n}(x) = \begin{cases} T_{\tilde{A}^n}^L(x) & \text{if } a_1^T \leq x \leq a_2 \\ T_{\tilde{A}^n}^R(x) & \text{if } a_2 \leq x \leq a_3^T; \\ 0 & \text{otherwise} \end{cases} \quad (1.6)$$

$$I_{\tilde{A}^n}(x) = \begin{cases} I_{\tilde{A}^n}^L(x) & \text{if } b_1^I \leq x \leq b_2 \\ I_{\tilde{A}^n}^R(x) & \text{if } b_2 \leq x \leq b_3^I \\ 0 & \text{otherwise} \end{cases} \quad (1.7)$$

$$F_{\tilde{A}^n}(x) = \begin{cases} F_{\tilde{A}^n}^L(x) & \text{if } c_1^F \leq x \leq c_2 \\ F_{\tilde{A}^n}^R(x) & \text{if } c_2 \leq x \leq c_3^F \\ 0 & \text{otherwise} \end{cases} \quad (1.8)$$

The sum of three independent membership degree of SVN  $\tilde{A}^n$  lie between the interval  $[0,3]$  .i.e  $0 \leq T_{\tilde{A}^n}^R(x) + I_{\tilde{A}^n}^R(x) + F_{\tilde{A}^n}^R(x) \leq 3 \quad x \in \tilde{A}^n$  .

### 1.13 Generalized Triangular Neutrosophic Number(GTNN)

A generalized single valued triangular neutrosophic number  $\tilde{A}^n$  with the set of parameters  $c_1^F \leq b_1^I \leq a_1^T \leq c_2 \leq b_2 \leq a_2 \leq a_3^T \leq b_3^I \leq c_3^F$  denoted as

$\tilde{A}^n = ((a_1^T, a_2, a_3^T; w_a), (b_1^I, b_2, b_3^I; \eta_a), (c_1^F, c_2, c_3^F; \tau_a))$  is the set of real numbers  $\mathfrak{R}$ . The truth membership, indeterminacy membership and falsity membership functions of  $\tilde{A}^n$  can be defined as follows

$$T_{\tilde{A}^n} = \begin{cases} w_a \frac{x - a_1^T}{a_2 - a_1^T} & \text{for } a_1^T \leq x \leq a_2 \\ w_a & \text{for } x = a_2 \\ w_a \frac{a_3^T - x}{a_3^T - a_2} & \text{for } a_2 \leq x \leq a_3^T \\ 0 & \text{otherwise} \end{cases} \quad (1.10)$$

$$I_{\tilde{A}^n} = \begin{cases} \eta_a \frac{x-b_1^I}{b_2-b_1^I} & \text{for } b_1^I \leq x \leq b_2 \\ \eta_a & \text{for } x = b_2 \\ \eta_a \frac{x-b_3^I}{b_3^I-b_2} & \text{for } b_2 \leq x \leq b_3^I \\ 0 & \text{otherwise} \end{cases} \quad (1.11)$$

$$F_{\tilde{A}^n} = \begin{cases} \tau_a \frac{x-c_1^F}{c_2-c_1^F} & \text{for } c_1^F \leq x \leq c_2 \\ \tau_a & \text{for } x = c_2 \\ \tau_a \frac{x-c_3^F}{c_3^F-c_2} & \text{for } c_2 \leq x \leq c_3^F \\ 0 & \text{otherwise} \end{cases} \quad (1.12)$$

### 1.14 $(\alpha, \beta, \gamma)$ - Cut of Single Valued Triangular Neutrosophic Number(SVTNN)

Let  $\tilde{A}^n = ((a_1^T, a_2, a_3^T; w_a), (b_1^I, b_2, b_3^I; \eta_a), (c_1^F, c_2, c_3^F; \tau_a))$  be generalized single valued triangular neutrosophic number. Then it is a crisp subset of  $\mathfrak{R}$  and is defined by

$$\begin{aligned} A_{\alpha, \beta, \gamma}^n &= \{x \mid T_{\tilde{A}^n}(x) \geq \alpha, I_{\tilde{A}^n}(x) \leq \beta, F_{\tilde{A}^n}(x) \leq \gamma\} \\ &= \left\{ \left[ L^\alpha(\tilde{A}^n), R^\alpha(\tilde{A}^n) \right], \left[ L^\beta(\tilde{A}^n), R^\beta(\tilde{A}^n) \right], \left[ L^\gamma(\tilde{A}^n), R^\gamma(\tilde{A}^n) \right] \right\} \\ &= \left\{ \left[ \begin{aligned} & \left[ a_1^T + \frac{\alpha}{w_a}(a_2 - a_1^T), a_3^T - \frac{\alpha}{w_a}(a_3^T - a_2) \right], \\ & \left[ b_1^I + \frac{\beta}{\eta_a}(b_2 - b_1^I), b_3^I + \frac{\beta}{\eta_a}(b_3^I - b_2) \right], \\ & \left[ c_1^F + \frac{\gamma}{\tau_a}(c_2 - c_1^F), c_3^F + \frac{\gamma}{\tau_a}(c_3^F - c_2) \right] \end{aligned} \right] \right\} \end{aligned} \quad (1.13)$$

### 1.15 Ranking of Triangular Neutrosophic Number

A triangular neutrosophic number  $\tilde{A}^n = ((a_1^T, a_2, a_3^T; w_a), (b_1^I, b_2, b_3^I; \eta_a), (c_1^F, c_2, c_3^F; \tau_a))$  is completely defined by

$$L_T(x) = w_a \frac{x - a_1^T}{a_2 - a_1^T} \text{ for } a_1^T \leq x \leq a_2 \quad (1.14)$$

and

$$R_T(x) = w_a \frac{a_3^T - x}{a_3^T - a_2} \text{ for } a_2 \leq x \leq a_3^T; \quad (1.15)$$

$$L_I(x) = \eta_a \frac{x - b_1^I}{b_2 - b_1^I} \text{ for } b_1^I \leq x \leq b_2 \quad (1.16)$$

and

$$R_I(x) = \eta_a \frac{x - b_3^I}{b_3^I - b_2} \text{ for } b_2 \leq x \leq b_3^I; \quad (1.17)$$

$$L_F(x) = \tau_a \frac{x - c_1^F}{c_2 - c_1^F} \text{ for } c_1^F \leq x \leq c_2 \quad (1.18)$$

$$\text{and } R_F(x) = \tau_a \frac{x - c_3^F}{c_3^F - c_2} \text{ for } c_2 \leq x \leq c_3^F \quad (1.19)$$

.The inverse functions can be analytically expressed as

$$L_T^{-1}(h) = a_1^T + \frac{h}{w_a} (a_2 - a_1^T); \quad (1.20)$$

$$R_T^{-1}(h) = a_3^T - \frac{h}{w_a} (a_3^T - a_2);$$

(1.21)

$$L_I^{-1}(h) = b_1^I + \frac{h}{\eta_a} (b_2 - b_1^I); \quad (1.22)$$

$$R_I^{-1}(h) = b_3^I + \frac{h}{\eta_a} (b_3^I - b_2); \quad (1.23)$$

$$L_F^{-1}(h) = c_1^F + \frac{h}{\tau_a} (c_2 - c_1^F) \quad (1.24)$$

And

$$R_F^{-1}(h) = c_3^F + \frac{h}{\tau_a} (c_3^F - c_2) \quad (1.25)$$

Now left integral value of truth membership ,indeterminacy membership and falsity membership functions of  $\tilde{A}^n$  are

$$V_{L_T}(\tilde{A}^n) = \int_0^1 L_T^{-1}(h) = \frac{(2w_a - 1)a_1^T + a_2}{2w_a} \quad (1.26)$$

and

$$V_{L_I}(\tilde{A}^n) = \int_0^1 L_I^{-1}(h) = \frac{(2\eta_a - 1)b_1^I + b_2}{2\eta_a} \quad (1.27)$$

and

$$V_{L_F}(\tilde{A}^n) = \int_0^1 L_I^{-1}(h) = \frac{(2\tau_a - 1)c_1^v + c_2}{2\tau_a} \quad (1.28)$$

respectively

and right integral value of truth, indeterminacy and falsity membership functions are

$$V_{R_T}(\tilde{A}^n) = \int_0^1 R_T^{-1}(h) = \frac{(2w_a - 1)a_3^T + a_2}{2w_a}, \quad (1.29)$$

$$V_{R_I}(\tilde{A}^n) = \int_0^1 R_I^{-1}(h) = \frac{(2\eta_a + 1)b_3^I - b_2}{2\eta_a} \quad (1.30)$$

and

$$V_{R_F}(\tilde{A}^n) = \int_0^1 R_F^{-1}(h) = \frac{(2\tau_a + 1)c_3^F - c_2}{2\tau_a} \quad (1.31)$$

respectively.

The total integral value of the truth membership functions is

$$V_T^\alpha(\tilde{A}^n) = \frac{(2w_a - 1)a_3^T + a_2}{2w_a} \alpha + (1 - \alpha) \frac{(2w_a - 1)a_1^T + a_2}{2w_a} = \frac{a_2 + (2w_a - 1)\{\alpha a_3^T + (1 - \alpha)a_1^T\}}{2w_a}; \alpha \in [0, 1] \quad (1.32)$$

The total integral value of indeterminacy membership functions is

$$V_I^\beta(\tilde{A}^n) = \frac{(2\eta_a + 1)b_3^I - b_2}{2\eta_a} \beta + (1 - \beta) \frac{(2\eta_a - 1)b_1^I + b_2}{2\eta_a} = \frac{(1 - 2\beta)b_2 + b_3^I(2\beta + 2\eta_a - 1)}{2\eta_a}; \beta \in [0, 1] \quad (1.33)$$

The total integral value of falsity membership functions is

$$V_F^\gamma(\tilde{A}^n) = \frac{(2\tau_a + 1)c_3^F - c_2}{2\tau_a} \gamma + (1 - \gamma) \frac{(2\tau_a - 1)c_1^v + c_2}{2\tau_a} = \frac{(1 - 2\gamma)c_2 + c_3^I(2\gamma + 2\tau_a - 1)}{2\tau_a}; \gamma \in [0, 1] \quad (1.34)$$

Let  $\tilde{A}^n = ((a_1^T, a_2, a_3^T; w_a), (b_1^I, b_2, b_3^I; \eta_a)(c_1^F, c_2, c_3^F; \tau_a))$  and

$\tilde{B}^n = ((e_1^T, e_2, e_3^T; w_b), (f_1^I, f_2, f_3^I; \eta_b)(g_1^F, g_2, g_3^F; \tau_b))$  be two generalized triangular

neutrosophic number then the following conditions hold good

- i) If  $V_T^\alpha(\tilde{A}^n) < V_T^\alpha(\tilde{B}^n)$ ,  $V_I^\beta(\tilde{A}^n) < V_I^\beta(\tilde{B}^n)$ , and  $V_F^\gamma(\tilde{A}^n) < V_F^\gamma(\tilde{B}^n)$  for  $\alpha, \beta, \gamma \in [0, 1]$  then  $\tilde{A}^n < \tilde{B}^n$



- ii) If  $V_T^\alpha(\tilde{A}^n) > V_T^\alpha(\tilde{B}^n)$ ,  $V_I^\beta(\tilde{A}^n) > V_I^\beta(\tilde{B}^n)$ , and  $I_F^\gamma(\tilde{A}^n) > I_F^\gamma(\tilde{B}^n)$  for  $\alpha, \beta, \gamma \in [0, 1]$  then  $\tilde{A}^n > \tilde{B}^n$
- iii) If  $V_T^\alpha(\tilde{A}^n) = V_T^\alpha(\tilde{B}^n)$ ,  $V_I^\beta(\tilde{A}^n) = V_I^\beta(\tilde{B}^n)$ , and  $I_F^\gamma(\tilde{A}^n) = I_F^\gamma(\tilde{B}^n)$  for  $\alpha, \beta, \gamma \in [0, 1]$  then  $\tilde{A}^n = \tilde{B}^n$

## 1.16 Nearest Interval Approximation for Neutrosophic Number

Here we want to approximate an neutrosophic number

$$\tilde{A}^n = \left( (a_1^T, a_2, a_3^T; w_a), (b_1^I, b_2, b_3^I; \eta_a), (c_1^F, c_2, c_3^F; \lambda_a) \right) \text{ by a crisp model.}$$

Let  $\tilde{A}^n$  and  $\tilde{B}^n$  be two neutrosophic numbers. Then the distance between them can be measured according to Euclidean metric as

$$\begin{aligned} \tilde{d}_E^2 &= \frac{1}{2} \int_0^1 (T_{A_L}(\alpha) - T_{B_L}(\alpha))^2 d\alpha + \frac{1}{2} \int_0^1 (T_{A_U}(\alpha) - T_{B_U}(\alpha))^2 d\alpha \\ &+ \frac{1}{2} \int_0^1 (I_{A_L}(\alpha) - I_{B_L}(\alpha))^2 d\alpha + \frac{1}{2} \int_0^1 (I_{A_U}(\alpha) - I_{B_U}(\alpha))^2 d\alpha \\ &+ \frac{1}{2} \int_0^1 (F_{A_L}(\alpha) - F_{B_L}(\alpha))^2 d\alpha + \frac{1}{2} \int_0^1 (F_{A_U}(\alpha) - F_{B_U}(\alpha))^2 d\alpha \end{aligned} \quad (1.35)$$

Now we find a closed interval  $\tilde{C}_{d_E}(\tilde{A}^n) = [C_L, C_U]$  which is nearest to  $\tilde{A}^n$  with respect to the metric  $\tilde{d}_E$ . Again it is obvious that each real interval can also be considered as an

neutrosophic number with constant  $\alpha$ -cut  $[C_L, C_U]$  for all  $\alpha \in [0, 1]$ . Now we have to

minimize  $\tilde{d}_E(\tilde{A}^n, \tilde{C}_{d_E}(\tilde{A}^n))$  with respect to  $C_L$  and  $C_U$ , that is to minimize

$$\begin{aligned} F_1(C_L, C_U) &= \int_0^1 (T_{A_L}(\alpha) - C_L)^2 d\alpha + \int_0^1 (T_{A_U}(\alpha) - C_U)^2 d\alpha \\ &+ \int_0^1 (I_{A_L}(\alpha) - C_L)^2 d\alpha + \int_0^1 (I_{A_U}(\alpha) - C_U)^2 d\alpha \\ &+ \int_0^1 (F_{A_L}(\alpha) - C_L)^2 d\alpha + \int_0^1 (F_{A_U}(\alpha) - C_U)^2 d\alpha \end{aligned} \quad (1.36)$$

With respect to  $C_L$  and  $C_U$ . We define partial derivatives

$$\frac{\partial F_1(C_L, C_U)}{\partial C_L} = -2 \int_0^1 (T_{A_L}(\alpha) + I_{A_L}(\alpha) + F_{A_L}(\alpha)) d\alpha + 6C_L \quad (1.37)$$

$$\frac{\partial F_1(C_L, C_U)}{\partial C_U} = -2 \int_0^1 (T_{A_U}(\alpha) + I_{A_U}(\alpha) + F_{A_U}(\alpha)) d\alpha + 6C_U \quad (1.38)$$

And then we solve the system

$$\frac{\partial F_1(C_L, C_U)}{\partial C_L} = 0, \quad (1.39)$$

$$\frac{\partial F_1(C_L, C_U)}{\partial C_U} = 0. \quad (1.40)$$

The solution is

$$C_L = \int_0^1 \frac{T_{A_L}(\alpha) + I_{A_L}(\alpha) + F_{A_L}(\alpha)}{3} d\alpha; \quad (1.41)$$

$$C_U = \int_0^1 \frac{T_{A_U}(\alpha) + I_{A_U}(\alpha) + F_{A_U}(\alpha)}{3} d\alpha \quad (1.42)$$

$$\text{Since } \det \begin{pmatrix} \frac{\partial^2 F_1(C_L, C_U)}{\partial C_L^2} & \frac{\partial^2 F_1(C_L, C_U)}{\partial C_L \partial C_U} \\ \frac{\partial^2 F_1(C_L, C_U)}{\partial C_U \partial C_L} & \frac{\partial^2 F_1(C_L, C_U)}{\partial C_U^2} \end{pmatrix} = \begin{pmatrix} 6 & 0 \\ 0 & 6 \end{pmatrix} = 36 > 0 \quad (1.43)$$

then  $C_L$   $C_U$  mentioned above minimize  $F_1(C_L, C_U)$ . The nearest interval of the neutrosophic number  $\tilde{A}^n$  with respect to the matrix  $\tilde{d}_E$  is

$$\tilde{C}_{d_E}(\tilde{A}^n) = \left[ \int_0^1 \frac{T_{A_L}(\alpha) + I_{A_L}(\alpha) + F_{A_L}(\alpha)}{3} d\alpha, \int_0^1 \frac{T_{A_U}(\alpha) + I_{A_U}(\alpha) + F_{A_U}(\alpha)}{3} d\alpha \right] \quad (1.44)$$

$$= \left[ \frac{a_1^T + b_1^I + c_1^F}{3} + \frac{a_2 - a_1^T}{6w_a} + \frac{b_2 - b_1^I}{6\eta_a} + \frac{c_2 - c_1^F}{6\lambda_a}, \frac{a_3^T + b_3^I + c_3^F}{3} + \frac{a_2 - a_3^T}{6w_a} + \frac{b_3^I - b_2}{6\eta_a} + \frac{c_3^F - c_2}{6\lambda_a} \right]$$

### 1.17 Decision Making in Neutrosophic Environment

Decision making is a process of solving the problem in involving pursuing the goals under constraints. The outcome is a decision which should in an action. Decision making plays an

important role in an economic and business, management sciences, engineering and manufacturing, social and political science, biology and medicine, military, computer science etc. It is difficult process due to factors like incomplete information which tend to be presented in real life situations. In the decision making process our main target is to find the value from the selected set with highest degree of membership in the decision set and these values support the goals under constraints only. But there may arise situations where some values selected from the set cannot support i.e such values strongly against the goals under constraints which are non-admissible. In this case we find such values from the selected set with least degree of non-membership in the decision sets. Intuitionistic fuzzy sets only can handle incomplete information not the indeterminate information and inconsistent information which exists commonly belief in system. In neutrosophic set, indeterminacy is quantified explicitly and truth membership, indeterminacy membership and falsity membership are independent. So it is natural to adopt for that purpose the value from selected set with highest degree of truth membership ,indeterminacy membership and least degree of falsity membership in the decision set. These factors indicate that a decision making process takes place in neutrosophic environment.

### 1.18 Single-Objective Neutrosophic Geometric Programming

Let us consider a Neutrosophic Geometric Programming Problem as

(P1. 1)

$$\text{Min}^n f_0(x) \tag{1.45}$$

Subject to

$$f_j(x) \lesssim^n b_j \quad j=1,2,\dots,m \tag{1.46}$$

$$x > 0 \tag{1.47}$$

Here the symbol “ $\lesssim^n$ ” denotes the neutrosophic version of “ $\leq$ ”. Now for Neutrosophic geometric programming linear truth, falsity and indeterminacy membership functions can be represented as follows

$$\mu_j(f_j(x)) = \begin{cases} 1 & \text{if } f_j(x) \leq f_j^0 \\ \frac{f_j' - f_j(x)}{f_j' - f_j^0} & \text{if } f_j^0 \leq f_j(x) \leq f_j' \\ 0 & \text{if } f_j(x) \geq f_j' \end{cases} \tag{1.48}$$

$j = 0, 1, 2, \dots, m$

$$\nu_j(f_j(x)) = \begin{cases} 1 & \text{if } f_j(x) \leq (f_j' - f_j'') \\ \frac{f_j(x) - (f_j' - f_j'')}{f_j''} & \text{if } (f_j' - f_j'') \leq f_j(x) \leq f_j' \\ 0 & \text{if } f_j(x) \geq f_j' \end{cases} \quad (1.49)$$

$j = 0, 1, 2, \dots, m$

$$\sigma_j(f_j(x)) = \begin{cases} 1 & \text{if } f_j(x) \leq f_j^0 \\ \frac{(f_j' - f_j''') - f_j(x)}{(f_j' - f_j'') - f_j^0} & \text{if } f_j^0 \leq f_j(x) \leq (f_j' - f_j''') \\ 0 & \text{if } f_j(x) \geq (f_j' - f_j''') \end{cases} \quad (1.50)$$

Now a Neutrosophic Geometric programming problem(P1.1) with truth ,falsity and indeterminacy membership function can be written as

**(P1. 2)**

$$\text{Maximize } \mu_j(f_j(x)) \quad (1.51)$$

$$\text{Minimize } \nu_j(f_j(x)) \quad (1.52)$$

$$\text{Maximize } \sigma_j(f_j(x)) \quad (1.53)$$

$j = 0, 1, 2, \dots, m$

Considering equal importance of all truth,falsity and indeterminacy membership functions and using weighted sum method the above optimization problem reduces to

**(P1. 3)**

$$\text{Maximize } V_A = \sum_{j=0}^m \{ \mu_j(f_j(x)) - \nu_j(f_j(x)) + \sigma_j(f_j(x)) \} \quad (1.54)$$

Subject to

$$x \geq 0 \quad (1.55)$$

The above problem is equivalent to

**(P1. 4)**

$$\text{Minimize } V_{A1} = \sum_{j=0}^m \left\{ \left( \frac{1}{f'_j - f_j^0} + \frac{1}{f_j^n} + \frac{1}{f'_j - f_j^n - f_j^0} \right) f_j(x) - \left( \frac{f'_j - f_j^n}{f_j^n} + \frac{f'_j}{f'_j - f_j^0} + \frac{f'_j - f_j^n}{f'_j - f_j^n - f_j^0} \right) \right\} \quad (1.56)$$

Subject to

$$f_j(x) = \sum_{k=1}^{N_j} C_{jk} \prod_{i=1}^n x_i^{a_{jki}} \leq 1 \quad j = 1, 2, \dots, m \quad (1.57)$$

$$x_i \geq 0 \quad i = 1, 2, \dots, n \quad (1.58)$$

Where  $C_{jk} > 0$  and  $a_{jki}$  are all real.  $x = (x_1, x_2, \dots, x_n)^T$ .

The posynomial Geometric Programming problem can be solved by usual geometric programming technique.

### 1.19 Numerical Example of Neutrosophic Geometric Programming

Consider an Intuitionistic Fuzzy Nonlinear Programming Problem as

(P1. 5)

$$\text{Minimize } f_0(x_1, x_2) = 2x_1^{-2}x_2^{-3} \quad (\text{target value } 57.87 \text{ with tolerance } 2.91) \quad (1.59)$$

Subject to

$$f_1(x_1, x_2) = x_1^{-1}x_2^{-1} \leq 6.75 \quad (\text{with tolerance } 2.91) \quad (1.60)$$

$$f_2(x_1, x_2) = x_1 + x_2 \leq 1 \quad (1.61)$$

$$x_1, x_2 > 0$$

Here linear truth, falsity and indeterminacy membership functions for fuzzy objectives and constraints goals are

$$\mu_0(f_0(x_1, x_2)) = \begin{cases} 1 & \text{if } 2x_1^{-2}x_2^{-3} \leq 57.87 \\ \frac{60.78 - 2x_1^{-2}x_2^{-3}}{2.91} & \text{if } 57.87 \leq 2x_1^{-2}x_2^{-3} \leq 60.78 \\ 0 & \text{if } 2x_1^{-2}x_2^{-3} \geq 60.78 \end{cases} \quad (1.62)$$

$$\mu_1(f_1(x_1, x_2)) = \begin{cases} 1 & \text{if } x_1^{-1}x_2^{-1} \leq 6.75 \\ \frac{6.94 - x_1^{-1}x_2^{-1}}{0.19} & \text{if } 6.75 \leq x_1^{-1}x_2^{-1} \leq 6.94 \\ 0 & \text{if } x_1^{-1}x_2^{-1} \geq 6.94 \end{cases} \quad (1.63)$$

$$\nu_0(f_0(x_1, x_2)) = \begin{cases} 1 & \text{if } 2x_1^{-2}x_2^{-3} \leq 59.03 \\ \frac{2x_1^{-2}x_2^{-3} - 59.03}{1.75} & \text{if } 59.03 \leq 2x_1^{-2}x_2^{-3} \leq 60.78 \\ 0 & \text{if } 2x_1^{-2}x_2^{-3} \geq 60.78 \end{cases} \quad (1.64)$$

$$\nu_1(f_1(x_1, x_2)) = \begin{cases} 1 & \text{if } x_1^{-1}x_2^{-2} \leq 6.83 \\ \frac{x_1^{-1}x_2^{-2} - 6.83}{0.11} & \text{if } 6.83 \leq x_1^{-1}x_2^{-2} \leq 6.94 \\ 0 & \text{if } x_1^{-1}x_2^{-2} \geq 6.94 \end{cases} \quad (1.65)$$

$$\sigma_0(f_0(x_1, x_2)) = \begin{cases} 1 & \text{if } 2x_1^{-2}x_2^{-3} \leq 57.87 \\ \frac{59.50 - 2x_1^{-2}x_2^{-3}}{1.63} & \text{if } 57.87 \leq 2x_1^{-2}x_2^{-3} \leq 59.50 \\ 0 & \text{if } 2x_1^{-2}x_2^{-3} \geq 59.50 \end{cases} \quad (1.66)$$

$$\sigma_1(f_1(x_1, x_2)) = \begin{cases} 1 & \text{if } x_1^{-1}x_2^{-2} \leq 6.75 \\ \frac{6.88 - x_1^{-1}x_2^{-2}}{0.13} & \text{if } 6.75 \leq x_1^{-1}x_2^{-2} \leq 6.88 \\ 0 & \text{if } x_1^{-1}x_2^{-2} \geq 6.88 \end{cases} \quad (1.67)$$

Based on max-additive operator FGP (P1.5) reduces to

**(P1. 6)**

$$\text{Maximize } V_A(x_1, x_2) = \left( \frac{1}{0.19} + \frac{1}{0.11} + \frac{1}{0.13} \right) x_1^{-1}x_2^{-1} + \left( \frac{1}{2.91} + \frac{1}{1.75} + \frac{1}{1.63} \right) 2x_1^{-2}x_2^{-3} \quad (1.68)$$

Subject to

$$f_2(x_1, x_2) = x_1 + x_2 \leq 1 \quad (1.69)$$

$$x_1, x_2 > 0$$

Neglecting the constant term in the following model we have following crisp geometric programming problem as

**(P1. 7)**

$$\text{Maximize } V(x_1, x_2) = 22.046x_1^{-1}x_2^{-1} + 3.057132x_1^{-2}x_2^{-3} \quad (1.70)$$

Subject to

$$f_2(x_1, x_2) = x_1 + x_2 \leq 1 \quad (1.71)$$

$$x_1, x_2 > 0 \quad (1.72)$$

Here  $DD=4-(2+1)=1$

The dual problem of this GP is

$$\text{Max } d(w) = \left(\frac{22.046}{w_{01}}\right)^{w_{01}} \left(\frac{3.057132}{w_{02}}\right)^{w_{02}} \left(\frac{1}{w_{11}}\right)^{w_{11}} \left(\frac{1}{w_{12}}\right)^{w_{12}} (w_{11} + w_{12})^{(w_{11}+w_{12})} \quad (1.73)$$

Such that

$$w_{01} + w_{02} = 1 \quad (1.74)$$

$$-w_{01} - 2w_{02} + w_{11} = 0 \quad (1.75)$$

$$-2w_{01} - 3w_{02} + w_{12} = 0 \quad (1.76)$$

$$\text{So } w_{02} = 1 - w_{01}; w_{11} = 2 - w_{01}; w_{12} = 3 - w_{01}; \quad (1.77)$$

$$\text{Maximize } d(w_{01}) = \left(\frac{22.046}{w_{01}}\right)^{w_{01}} \left(\frac{3.057132}{1-w_{01}}\right)^{(1-w_{01})} \left(\frac{1}{2-w_{01}}\right)^{(2-w_{01})} \left(\frac{1}{3-w_{01}}\right)^{(3-w_{01})} (5-2w_{01})^{(5-2w_{01})} \quad (1.78)$$

Subject to

$$0 < w_{01} < 1 \quad (1.79)$$

$$\text{For optimality, } \frac{d(d(w_{01}))}{dw_{01}} = 0 \quad (1.80)$$

$$22.046(1-w_{01})(2-w_{01})(3-w_{01}) = 3.057132w_{01}(5-2w_{01})^2 \quad (1.81)$$

$$w_{01}^* = 0.6260958, w_{02}^* = 0.3739042, w_{11}^* = 1.3739042, w_{12}^* = 2.3739042, \quad (1.82)$$

$$x_1^* = 0.366588, x_2^* = 0.633411, \quad (1.83)$$

$$f_0^*(x_1^*, x_2^*) = 58.56211, \quad f_1^*(x_1^*, x_2^*) = 6.799086, \quad (1.84)$$

## 1.20 Application of Neutrosophic Geometric Programming in Gravel Box Design Problem

Gravel Box Problem: A total of 800 cubic meters of gravel is to be ferried across a river on a barrage. A box (with an open top) is to be built for this purpose. After the entire gravel has been ferried, the box is to be discarded. The transport cost of round trip of barrage of box is Rs 1 and the cost of materials of the ends of the box are Rs 20/m<sup>2</sup> and cost of the material of

other two sides and bottom are Rs 10/m<sup>2</sup> and Rs 80/m<sup>2</sup> respectively. Find the dimension of the gravel box that is to be built for this purpose and the total optimal cost. Let length, width and height of the box be  $x_1$  m,  $x_2$  m,  $x_3$  m respectively. The area of the end of the gravel box is  $x_2x_3$  m<sup>2</sup>. The area of the sides and bottom of the gravel box are  $x_1x_3$  m<sup>2</sup> and  $x_1x_2$  m<sup>2</sup> respectively. The volume of the gravel box is  $x_1x_2x_3$  m<sup>3</sup>. Transport cost is Rs  $\frac{80}{x_1x_2x_3}$ . Material cost is  $40x_2x_3$ .

So the gravel box problem can be formulated as multi-objective geometric programming problem as

**(P1. 8)**

$$\text{Minimize } f_1(x_1, x_2, x_3) = \frac{80}{x_1x_2x_3} + 40x_2x_3 \quad (1.85)$$

$$\text{Minimize } f_2(x_1, x_2, x_3) = \frac{80}{x_1x_2x_3} \quad (1.86)$$

Such that

$$x_1x_2 + 2x_1x_3 \leq 4 \quad (1.87)$$

$$x_1, x_2, x_3 > 0 \quad (1.88)$$

Here objective goal is 90 (with truth tolerance 8, falsity tolerance 5 and indeterminacy tolerance 5)

And constraint goal

$f_1(x_1, x_2, x_3) \leq 4$  (with truth tolerance 0.9, falsity tolerance 0.5 and indeterminacy tolerance 0.6)

$$x_1^* = 2.4775, x_2^* = 0.1271, x_3^* = 0.5635, \quad (1.89)$$

$$f_0^*(x_1^*, x_2^*) = 76.237, \quad f_1^*(x_1^*, x_2^*) = 4.5856,$$

## 1.21 Multi-Objective Neutrosophic Geometric Programming Problem

A multi-objective geometric programming problem can be defined as

**(P1. 9)**



$$\text{Find } X = (x_1, x_2, \dots, x_n)^T \quad (1.90)$$

So as to

$$\text{Minimize } f_{k0}(x) = \sum_{t=1}^{T_{k0}} C_{k0t} \prod_{j=1}^n x_j^{a_{k0tj}} \quad k = 1, 2, \dots, p \quad (1.91)$$

Such that

$$f_i(x) = \sum_{t=1}^{T_i} C_{it} \prod_{j=1}^n x_j^{a_{itj}} \leq 1 \quad i = 1, 2, \dots, m \quad j = 1, 2, \dots, n \quad (1.92)$$

$$x_j > 0,$$

Where  $C_{kt}, C_{it} > 0$  for all  $k$  and  $t$ .  $a_{ktj}, a_{itj}$  are real for all  $i, t, k, j$

### Computational Algorithm

**Step-I:** Solve the MONLP problem (P1.9) as a single objective non-linear problem  $p$  times for each problem by taking one of the objectives at a time and ignoring the others. These solutions are known as ideal solutions. Let  $x_k$  be the respective optimal solution for the  $k$  th different objective and evaluate each objective values for all these  $k$  th optimal solution.

**Step-II:** From the result of step-1, determine the corresponding values for every objective for each derived solution. With the values of all objectives at each ideal solution, pay-off matrix can be formulated as follows

$$\begin{array}{cccc} & f_1(x) & f_2(x) & \dots & f_p(x) \\ \begin{array}{c} x^1 \\ x^2 \\ \dots \\ x^p \end{array} & \left[ \begin{array}{cccc} f_1(x^1) & f_2(x^1) & \dots & f_p(x^1) \\ f_1(x^2) & f_2(x^2) & \dots & f_p(x^2) \\ \dots & \dots & \dots & \dots \\ f_1(x^p) & f_2(x^p) & \dots & f_p(x^p) \end{array} \right] \end{array}$$

**Step-III:** For each objective  $f_k(x)$ , find lower bound  $L_k^\mu$  and upper bound  $U_k^\mu$

$$U_k^\mu = \max \{f_k(x^r)\} \quad (1.93)$$

$$\text{and } L_k^\mu = \min \{f_k(x^r)\} \quad (1.94)$$

where  $1 \leq r \leq k$  for truth membership of objectives.

**Step-IV:** We represent upper and lower bounds for indeterminacy and falsity membership of objective as follows

$$U_k^\nu = U_k^\mu \quad (1.95)$$

$$\text{and } L_k^\nu = L_k^\mu + t(U_k^\mu - L_k^\mu) \quad (1.96)$$

$$L_k^\sigma = L_k^\mu \quad (1.97)$$

$$\text{and } U_k^\sigma = L_k^\mu + s(U_k^\mu - L_k^\mu) \quad (1.98)$$

**Step-V:** Define Truth membership, indeterminacy membership and falsity membership as follows

$$\mu_k(f_k(x)) = \begin{cases} 1 & \text{if } f_k \leq L_k^\mu \\ \frac{U_k^\mu - f_k(x)}{U_k^\mu - L_k^\mu} & \text{if } L_k^\mu \leq f_k \leq U_k^\mu \\ 0 & \text{if } f_k \geq U_k^\mu \end{cases} \quad (1.99)$$

$$\text{Then } \nu_k(f_k(x)) = 1 - \frac{1}{1-t} \mu_k(f_k(x)) \quad (1.100)$$

$$\text{and } \sigma_k(f_k(x)) = \frac{1}{s} \mu_k(f_k(x)) - \frac{1-s}{s} \quad (1.101)$$

for  $k = 1, 2, \dots, p$

It is obvious that

$$\sigma_k(f_k(x)) = \begin{cases} 1 & \text{if } f_k \leq L_k^\sigma \\ \frac{U_k^\sigma - f_k(x)}{U_k^\sigma - L_k^\sigma} & \text{if } L_k^\sigma \leq f_k \leq U_k^\sigma \\ 0 & \text{if } f_k \geq U_k^\sigma \end{cases} \quad (1.102)$$

$$\nu_k(f_k(x)) = \begin{cases} 1 & \text{if } f_k \leq L_k^\nu \\ \frac{f_k(x) - L_k^\nu}{U_k^\nu - L_k^\nu} & \text{if } L_k^\nu \leq f_k \leq U_k^\nu \\ 0 & \text{if } f_k \geq U_k^\nu \end{cases} \quad (1.103)$$

and  $0 \leq \mu_k(f_k(x)) + \nu_k(f_k(x)) + \sigma_k(f_k(x)) \leq 3$  for  $k = 1, 2, \dots, p$

**Step-VI:** Now a neutrosophic geometric programming technique for multi-objective non-linear programming problem with truth membership, falsity membership and indeterminacy membership function can be written as

**(P1. 10)**

$$\text{Maximize } (\mu_1(f_1(x)), \mu_2(f_2(x)), \dots, \mu_p(f_p(x))) \quad (1.104)$$

$$\text{Minimize } (v_1(f_1(x)), v_2(f_2(x)), \dots, v_p(f_p(x))) \quad (1.105)$$

$$\text{Maximize } (\sigma_1(f_1(x)), \sigma_2(f_2(x)), \dots, \sigma_p(f_p(x))) \quad (1.106)$$

Such that

$$f_i(x) = \sum_{t=1}^{T_i} C_{it} \prod_{j=1}^n x_j^{a_{ij}} \leq 1 \quad i = 1, 2, \dots, m \quad j = 1, 2, \dots, n \quad (1.107)$$

$$x_j > 0,$$

Where  $C_{it} > 0$  for all  $i$  and  $t$ .  $a_{ij}$  are real for all  $i, t, j$

Using weighted sum method the multi-objective nonlinear programming problem (P1.10) reduces to

**(P1. 11)**

$$\text{Minimize } V_{MA}(x) = \sum_{k=1}^p w_k (v_k(f_k(x)) - \mu_k(f_k(x)) - \sigma_k(f_k(x))) \quad (1.108)$$

$$\text{Minimize } V_{MA}(x) = \left(1 + \frac{1}{1-t} + \frac{1}{s}\right) \sum_{k=1}^p w_k \frac{\sum_{t=1}^{T_k} C_{kt} \prod_{j=1}^n x_j^{a_{kj}}}{U_k^\mu - L_k^\mu} - \left\{ \left(1 + \frac{1}{1-t} + \frac{1}{s}\right) \sum_{k=1}^p w_k \frac{U_k^\mu}{U_k^\mu - L_k^\mu} \right\} - \frac{1}{s} \quad (1.109)$$

Such that

$$f_i(x) = \sum_{t=1}^{T_i} C_{it} \prod_{j=1}^n x_j^{a_{ij}} \leq 1 \quad i = 1, 2, \dots, m \quad j = 1, 2, \dots, n \quad (1.110)$$

$$x_j > 0,$$

Where  $C_{it} > 0$  for all  $i$  and  $t$ .  $a_{ij}$  are real for all  $i, t, j$

Excluding the constant term, the problem (P1.11) reduces to the following geometric programming problem

**(P1. 12)**

$$\text{Minimize } V_{MA1}(x) = \left(1 + \frac{1}{1-t} + \frac{1}{s}\right) \sum_{k=1}^p w_k \frac{\sum_{i=1}^{T_k} C_{kt} \prod_{j=1}^n x_j^{a_{ktj}}}{U_k^\mu - L_k^\mu} \quad (1.111)$$

Such that

$$f_i(x) = \sum_{t=1}^{T_i} C_{it} \prod_{j=1}^n x_j^{a_{ijt}} \leq 1 \quad i = 1, 2, \dots, m \quad j = 1, 2, \dots, n \quad (1.112)$$

$$x_j > 0,$$

Where  $C_{it} > 0$  for all  $i$  and  $t$ .  $a_{ijt}$  are real for all  $i, t, j$

Here  $t, s \in (0, 1)$  are predetermined real numbers.

$$\text{Where } V_{MA}(f_k(x)) = V_{MA1}(f_k(x)) - \left\{ \left( \left(1 + \frac{1}{1-t} + \frac{1}{s}\right) \sum_{k=1}^p w_k \frac{U_k^\mu}{U_k^\mu - L_k^\mu} \right) - \frac{1}{s} \right\} \quad (1.113)$$

Here (P1.12) is a posynomial geometric programming problem with

$$DD = \sum_{k=1}^p T_{k0} + \sum_{i=1}^m T_i - n - 1 \quad (1.114)$$

It can be solved by usual geometric programming technique

## 1.22 Definition: Neutrosophic Pareto (or NS Pareto) Optimal Solution

A decision variable  $x^* \in X$  is said to be a NS Pareto optimal solution to the Neutrosophic GPP (P1.11) if there does not exist another  $x \in X$  such that  $\mu_k(f_k(x)) \leq \mu_k(f_k(x^*))$ ,  $\nu_k(f_k(x)) \geq \nu_k(f_k(x^*))$  and  $\sigma_k(f_k(x)) \leq \sigma_k(f_k(x^*))$  for all  $k = 1, 2, \dots, p$  and  $\mu_j(f_j(x)) \neq \mu_j(f_j(x^*))$ ,  $\nu_j(f_j(x)) \neq \nu_j(f_j(x^*))$  and  $\sigma_j(f_j(x)) \neq \sigma_j(f_j(x^*))$  for at least  $j = 1, 2, \dots, p$

## 1.23 Theorem 1

The solution of (P1.9) based on weighted sum method Neutrosophic GP Problem (P1.10) is weakly NS Pareto optimal.

**Proof:**

Let  $x^* \in X$  be the solution of Neutrosophic GP Problem. Let us suppose that it is not weakly M-N pareto optimal. In this case there exist another  $x \in X$  such that  $\mu_k(f_k(x)) < \mu_k(f_k(x^*))$ ,  $\nu_k(f_k(x)) > \nu_k(f_k(x^*))$  and  $\sigma_k(f_k(x)) < \sigma_k(f_k(x^*))$  for all  $k=1,2,\dots,p$ . Observe that  $\mu_k(f_k(x))$  is strictly monotone decreasing function with respect to  $f_k(x)$ . This implies  $\mu_k(f_k(x)) > \mu_k(f_k(x^*))$  and  $\nu_k(f_k(x))$  is monotone increasing function with respect to  $f_k(x)$ . This implies  $\nu_k(f_k(x)) < \nu_k(f_k(x^*))$  and  $\sigma_k(f_k(x))$  is strictly monotone decreasing function with respect to  $f_k(x)$ , so  $\sigma_k(f_k(x)) > \sigma_k(f_k(x^*))$ . Thus we have

$$\sum_{k=1}^p w_k \mu_k(f_k(x)) > \sum_{k=1}^p w_k \mu_k(f_k(x^*)), \sum_{k=1}^p w_k \nu_k(f_k(x)) < \sum_{k=1}^p w_k \nu_k(f_k(x^*))$$

$$\text{and } \sum_{k=1}^p w_k \sigma_k(f_k(x)) > \sum_{k=1}^p w_k \sigma_k(f_k(x^*)).$$

This is a contradiction to the assumption that  $x^*$  is a solution of Neutrosophic GP Problem (P1.9). Thus  $x^*$  is a weakly NS Pareto Optimal.

## 1.24 Theorem 2

The unique solution of Neutrosophic GP Problem (P1.10) based on weighted sum method is weakly NS Pareto optimal.

### Proof:

Let  $x^* \in X$  be the solution of Neutrosophic GP Problem. Let us suppose that it is not weakly NS pareto optimal. In this case there exist another  $x \in X$  such that  $\mu_k(f_k(x)) \leq \mu_k(f_k(x^*))$ ,  $\nu_k(f_k(x)) \geq \nu_k(f_k(x^*))$  and  $\sigma_k(f_k(x)) \leq \sigma_k(f_k(x^*))$  for all  $k=1,2,\dots,p$

and  $\mu_l(f_l(x)) < \mu_l(f_l(x^*))$ ,  $\nu_l(f_l(x)) > \nu_l(f_l(x^*))$  for at least one  $l$ . Observe that  $\mu_k(f_k(x))$  is strictly monotone decreasing function with respect to  $f_k(x)$ , this implies  $\mu_k(f_k(x)) > \mu_k(f_k(x^*))$  and  $\nu_k(f_k(x))$  is monotone increasing function with respect to  $f_k(x)$ . This implies  $\nu_k(f_k(x)) < \nu_k(f_k(x^*))$  and  $\sigma_k(f_k(x))$  is strictly monotone decreasing function with respect to  $f_k(x)$ , this implies  $\sigma_k(f_k(x)) > \sigma_k(f_k(x^*))$ . Thus we have

$$\sum_{k=1}^p w_k \mu_k(f_k(x)) \geq \sum_{k=1}^p w_k \mu_k(f_k(x^*)), \sum_{k=1}^p w_k \nu_k(f_k(x)) \leq \sum_{k=1}^p w_k \nu_k(f_k(x^*))$$

and  $\sum_{k=1}^p w_k \sigma_k(f_k(x)) \geq \sum_{k=1}^p w_k \sigma_k(f_k(x^*))$ . On the other hand uniqueness of  $x^*$  means that

$$\sum_{k=1}^p w_k \mu_k(f_k(x)) < \sum_{k=1}^p w_k \mu_k(f_k(x^*)), \sum_{k=1}^p w_k \nu_k(f_k(x)) > \sum_{k=1}^p w_k \nu_k(f_k(x^*))$$

$\sum_{k=1}^p w_k \sigma_k(f_k(x)) < \sum_{k=1}^p w_k \sigma_k(f_k(x^*))$ . The two sets inequalities above are contradictory and thus  $x^*$  is weakly pareto optimal.

## 1.25 Illustrated Numerical Example

A multi-objective nonlinear programming problem can be written as

(P1. 13)

$$\text{Minimize } f_1(x_1, x_2) = x_1^{-1} x_2^{-2} \quad (1.115)$$

$$\text{Minimize } f_2(x_1, x_2) = 2x_1^{-2} x_2^{-3}$$

(1.116)

$$\text{Such that } x_1 + x_2 \leq 1 \quad (1.117)$$

Here the pay-off matrix is

$$\begin{array}{cc} f_1(x_1, x_2) & f_2(x_1, x_2) \\ x_1 \left[ \begin{array}{cc} 6.75 & 60.78 \end{array} \right] \\ x_2 \left[ \begin{array}{cc} 6.94 & 57.87 \end{array} \right] \end{array}$$

The truth membership, falsity membership and indeterminacy membership can be defined as follows

$$\mu_1(f_1(x)) = \begin{cases} 1 & \text{if } x_1^{-1} x_2^{-2} \leq 6.75 \\ \frac{6.94 - x_1^{-1} x_2^{-2}}{0.19} & \text{if } 6.75 \leq x_1^{-1} x_2^{-2} \leq 6.94 \\ 0 & \text{if } x_1^{-1} x_2^{-2} \geq 6.94 \end{cases} \quad (1.118)$$

$$\mu_2(f_2(x)) = \begin{cases} 1 & \text{if } 2x_1^{-2} x_2^{-3} \leq 57.87 \\ \frac{60.78 - 2x_1^{-2} x_2^{-3}}{2.91} & \text{if } 57.87 \leq 2x_1^{-2} x_2^{-3} \leq 60.78 \\ 0 & \text{if } 2x_1^{-2} x_2^{-3} \geq 60.78 \end{cases} \quad (1.119)$$

$$v_1(f_1(x)) = 1 - \frac{1}{1-t} \mu_1(f_1(x)), \quad (1.120)$$

$$v_2(f_2(x)) = 1 - \frac{1}{1-t} \mu_2(f_2(x)) \quad (1.121)$$

$$\text{and } \sigma_1(f_1(x)) = \frac{1}{s} \mu_1(f_1(x)) - \frac{1-s}{s}, \quad (1.122)$$

$$\sigma_2(f_2(x)) = \frac{1}{s} \mu_2(f_2(x)) - \frac{1-s}{s} \quad (1.123)$$

**Table 1.1 Optimal values of primal, dual variables and objective functions from Neutrosophic Geometric Programming Problem for different weights**

Weights $w_1, w_2$	Optimal Dual Variables $w_{01}^*, w_{02}^*, w_{11}^*, w_{12}^*$	Optimal Primal Variables $x_1^*, x_2^*$	Optimal Objectives $f_1^*(x_1^*, x_2^*), f_2^*(x_1^*, x_2^*)$	Sum of the Optimal Objectives $f_1^*(x_1^*, x_2^*) + f_2^*(x_1^*, x_2^*)$
0.5, 0.5	0.6491609 0.3508391 1.3508391 2.3508391	0.3649261 0.6491609	6.794329 58.53371	65.32803
0.9, 0.1	0.9415706 0.0584294 1.0584294 2.0584294	0.3395821 0.6604179	6.751768 60.21212	66.96388
0.1, 0.9	0.1745920 0.8254080 1.8254080 2.8254080	0.3924920 0.6075080	6.903434 57.90451	64.80794

**Table 1.2 Comparison of optimal solutions by IFGP and NSGP technique**

Optimization Techniques	Optimal Primal Variables $x_1^*, x_2^*$	Optimal Objectives $f_1^*(x_1^*, x_2^*), f_2^*(x_1^*, x_2^*)$	Sum of the Optimal Objectives $f_1^*(x_1^*, x_2^*) + f_2^*(x_1^*, x_2^*)$
Intuitionistic Fuzzy Geometric Programming (IFGP)	0.36611 0.63389	6.797678 58.58212	65.37980
Proposed Neutrosophic Geometric Programming Technique	0.3649261 0.6491609	6.794329 58.53371	65.32803

In Table 1.2, It has been seen that NSGP technique gives better optimal result than IFGP technique

### 1.26 Application of Neutrosophic Optimization in Gravel Box Design Problem

Gravel Box Problem: A total of 800 cubic meters of gravel is to be ferried across a river on a barrage. A box (with an open top) is to be built for this purpose. After the entire gravel has been ferried, the box is to be discarded. The transport cost of round trip of barrage of box is Rs 1 and the cost of materials of other two sides and bottom are Rs 10/m<sup>2</sup>. Find the dimension of the gravel box that is to be built for this purpose and the total optimal cost. Let length width and height of the box be  $x_1$  m,  $x_2$  m,  $x_3$  m respectively. The area of the end of the gravel box is  $x_2x_3$  m<sup>2</sup>. The area of the sides and bottom of the gravel box are  $x_1x_3$  m<sup>2</sup> and  $x_1x_2$  m<sup>2</sup> respectively. The volume of the gravel box is  $x_1x_2x_3$  m<sup>3</sup>. Transport cost is Rs  $\frac{80}{x_1x_2x_3}$ . Material cost is  $40x_2x_3$ .

So the gravel box problem can be formulated as multi-objective geometric programming problem as

(P1. 14)

$$\text{Minimize } f_1(x_1, x_2, x_3) = \frac{80}{x_1x_2x_3} + 40x_2x_3 \tag{1.124}$$

$$\text{Minimize } f_2(x_1, x_2, x_3) = \frac{80}{x_1x_2x_3} \tag{1.125}$$

$$\text{Such that } x_1x_2 + 2x_1x_3 \leq 4 \tag{1.126}$$

$$x_1, x_2, x_3 > 0$$

**Solution:** Here pay off matrix is

$$\begin{matrix}
 f_1(x) & f_2(x) \\
 x^1 & \begin{bmatrix} 95.24 & 63.78 \\ 120 & 40 \end{bmatrix} \\
 x^2 &
 \end{matrix}$$

**Table 1.3 Comparison of optimal solutions of gravel box problem between IFGP and NSGP Method**

Optimization Techniques	Optimal Primal Variables $x_1^*, x_2^*, x_3^*$	Optimal Objectives $f_1^*(x_1^*, x_2^*),$	Sum of the Optimal Objectives $f_1^*(x_1^*, x_2^*) + f_2^*(x_1^*, x_2^*)$



		$f_2^*(x_1^*, x_2^*)$	
Intuitionistic Fuzzy Geometric Programming (IFGP)	1.2513842 1.5982302 0.7991151	101.1421624 50.0553670	151.1975294
Proposed Neutrosophic Geometric Programming Technique	1.2513843 1.5982300 0.7991150	101.1421582 50.0553655	151.1975237

### 1.27 Multi-Objective Neutrosophic Linear Programming Problem (MOLPP)

A general multi-objective linear programming problem with  $p$  objectives,  $q$  constraints and  $n$  decision variables may be taken in the following form

#### (P1. 15)

$$\text{Maximize } f_1(X) = C_1 X \quad (1.127)$$

$$\text{Maximize } f_2(X) = C_2 X \quad (1.128)$$

.....  
.....

$$\text{Maximize } f_p(X) = C_p X \quad (1.129)$$

$$\text{Subject to } AX \leq b \quad (1.130)$$

$$X \geq 0 \quad (1.131)$$

$$\text{Where } C_i = (c_{i1}, c_{i2}, \dots, c_{in}) \text{ for } i = 1, 2, \dots, p \quad (1.132)$$

$$A = [a_{ji}]_{q,n}; X = (x_1, x_2, \dots, x_n); b = (b_1, b_2, \dots, b_q)^T \text{ for } j = 1, 2, \dots, p; i = 1, 2, \dots, n \quad (1.133)$$

Consider the multi-objective linear programming problem as

#### (P1. 16)

$$\text{Maximize } \{f_1(x), f_2(x), \dots, f_p(x)\} \quad (1.134)$$

Subject to

$$AX \leq b \quad (1.135)$$

$$\text{Where } A = (a_{ij})_{q,n}, X = (x_1, x_2, \dots, x_n)^T, b = (b_1, b_2, \dots, b_q)^T \quad (1.136)$$

Now the decision set  $\tilde{D}^n$ , conjunction of neutrosophic objectives and constraints are defined

$$\text{as } \tilde{D}^n = \left( \bigcap_{k=1}^p \tilde{G}_k^n \right) \cap \left( \bigcap_{j=1}^q \tilde{C}_j^n \right) = \left\{ (x, T_{\tilde{D}^n}(x), I_{\tilde{D}^n}(x), F_{\tilde{D}^n}(x)) \right\} \quad (1.137)$$

Here

$$T_{\tilde{D}^n}(x) = \left( T_{\tilde{G}_1^n}(x), T_{\tilde{G}_2^n}(x), \dots, T_{\tilde{G}_p^n}(x); T_{\tilde{C}_1^n}(x), T_{\tilde{C}_2^n}(x), \dots, T_{\tilde{C}_q^n}(x) \right) \text{ for all } x \in X. \quad (1.138)$$

$$I_{\tilde{D}^n}(x) = \left( I_{\tilde{G}_1^n}(x), I_{\tilde{G}_2^n}(x), \dots, I_{\tilde{G}_p^n}(x); I_{\tilde{C}_1^n}(x), I_{\tilde{C}_2^n}(x), \dots, I_{\tilde{C}_q^n}(x) \right) \text{ for all } x \in X. \quad (1.139)$$

$$F_{\tilde{D}^n}(x) = \left( F_{\tilde{G}_1^n}(x), F_{\tilde{G}_2^n}(x), \dots, F_{\tilde{G}_p^n}(x); F_{\tilde{C}_1^n}(x), F_{\tilde{C}_2^n}(x), \dots, F_{\tilde{C}_q^n}(x) \right) \text{ for all } x \in X. \quad (1.140)$$

Here  $T_{\tilde{D}^n}(x), I_{\tilde{D}^n}(x), F_{\tilde{D}^n}(x)$  are Truth membership function, Indeterminacy membership function, Falsity membership Functions of Neutrosophic Decision set respectively. Now using the definition of Smarandache's intersection of neutrosophic sets and criteria of decision making, the optimum linear programming problem can be formulated as

### Model-I-AL,BL

(P1. 17)

$$\text{Max } \alpha \quad (1.141)$$

$$\text{Min } \beta \quad (1.142)$$

$$\text{Max } \gamma \quad (1.143)$$

Such that

$$T_{\tilde{G}_k^n}(x) \geq \alpha \quad (1.144)$$

$$T_{\tilde{C}_k^n}(x) \geq \alpha \quad (1.145)$$

$$I_{\tilde{G}_k^n}(x) \geq \gamma \quad (1.146)$$

$$I_{\tilde{C}_k^n}(x) \geq \gamma \quad (1.147)$$

$$T_{\tilde{G}_k^n}(x) \leq \beta \quad (1.148)$$

$$T_{\tilde{C}_k^n}(x) \leq \beta \quad (1.149)$$

$$k = 1, 2, \dots, p$$

$$\alpha + \beta + \gamma \leq 3 \tag{1.150}$$

$$\alpha \geq \beta; \tag{1.151}$$

$$\alpha \geq \gamma;$$

(1.152)

$$\alpha, \beta, \gamma \in [0, 1] \tag{1.153}$$

In this algorithm we have considered the indeterminacy membership function as of decreasing sense and increasing sense respectively in Model-I-AL and Model-BL respectively

But in real world situation a decision maker needs to minimize indeterminacy or hesitancy So using the another definition of Smarandache's intersection of neutrosophic sets and criteria of decision making the optimum linear programming problem is formulated as

#### **Model-II-AL,BL**

**(P1. 18)**

$$\text{Max } \alpha \tag{1.154}$$

$$\text{Min } \beta \tag{1.155}$$

$$\text{Min } \gamma \tag{1.156}$$

Such that

$$T_{\tilde{G}_k^n}(x) \geq \alpha \tag{1.157}$$

$$T_{\tilde{C}_k^n}(x) \geq \alpha \tag{1.158}$$

$$I_{\tilde{G}_k^n}(x) \leq \gamma \tag{1.159}$$

$$I_{\tilde{C}_k^n}(x) \leq \gamma \tag{1.160}$$

$$T_{\tilde{G}_k^n}(x) \leq \beta \tag{1.161}$$

$$T_{\tilde{C}_k^n}(x) \leq \beta \tag{1.162}$$

$$k = 1, 2, \dots, p$$

$$\alpha + \beta + \gamma \leq 3 \tag{1.163}$$

$$\alpha \geq \beta; \tag{1.164}$$

$$\alpha \geq \gamma; \tag{1.165}$$

$$\alpha, \beta, \gamma \in [0,1] \quad (1.166)$$

In this algorithm we have considered the indeterminacy membership function as per decreasing sense and increasing sense respectively in Model-II-AL and Model-II-BL.

**Computational Algorithm 1 (Linear Membership Function)**

**Step-I:** Pick the objective function and solve it as a single objective subjected to the constraints. Continue the process k-times for k different objective functions. Find value of objective functions and decision variables.

**Step-II:** To build membership functions, goals and tolerances should be determined at first. Using ideal solutions, obtained in step-I we find the values of all the objective functions at each ideal solution and construct pay-off matrix as follows

$$\begin{bmatrix} f_1^*(x^1) & f_2(x^1) & \dots & f_p(x^1) \\ f_2(x^2) & f_2^*(x^2) & \dots & f_2(x^2) \\ \dots & \dots & \dots & \dots \\ f_1(x^p) & f_2(x^p) & \dots & f_p^*(x^p) \end{bmatrix}$$

**Step-III:** From step-II we find the upper and lower bounds of each objective functions

$U_k^T = \max \{f_k(x_r^*)\}$  and  $L_k^T = \min \{f_k(x_r^*)\}$  where  $1 \leq r \leq k$  for truth membership functions of objectives.

**Step-IV:** We represent upper and lower bounds for indeterminacy and falsity membership of objectives as follows for

Model-I,II-AL,AN

$$L_k^I = L_k^T \text{ and } U_k^I = L_k^T - \lambda(U_k^T - L_k^T) \quad (1.167)$$

$$L_k^F = L_k^T - t(U_k^T - L_k^T) \quad (1.168)$$

$$U_k^F = U_k^T$$

for Model-I,II-BL,BN

$$U_k^F = U_k^T = U_k^I$$

$$L_k^F = L_k^T - t(U_k^T - L_k^T)$$

$$L_k^I = L_k^T - \lambda(U_k^T - L_k^T)$$

Here  $\lambda$  and  $t$  are two predominant real numbers in  $(0,1)$

**Step-V:** Define Truth membership, Indeterminacy membership, Falsity membership functions (For Model-I,II-AL,BL) as follows

$$T_k(f_k(x)) = \begin{cases} 1 & \text{if } f_k(x) \leq L_k^T \\ \frac{U_k^T - f_k(x)}{U_k^T - L_k^T} & \text{if } L_k^T \leq f_k(x) \leq U_k^T \\ 0 & \text{if } f_k(x) \geq U_k^T \end{cases} \quad (1.169)$$

For Model-I,II-AL

$$I_k(f_k(x)) = \begin{cases} 0 & \text{if } f_k(x) \leq L_k^I \\ \frac{U_k^I - f_k(x)}{U_k^I - L_k^I} & \text{if } L_k^I \leq f_k(x) \leq U_k^I \\ 1 & \text{if } f_k(x) \geq U_k^I \end{cases} \quad (1.170)$$

For Model-I,II-BL

$$I_k(f_k(x)) = \begin{cases} 0 & \text{if } f_k(x) \leq L_k^I \\ \frac{f_k(x) - L_k^I}{U_k^I - L_k^I} & \text{if } L_k^I \leq f_k(x) \leq U_k^I \\ 1 & \text{if } f_k(x) \geq U_k^I \end{cases} \quad (1.171)$$

$$F_k(f_k(x)) = \begin{cases} 0 & \text{if } f_k(x) \leq L_k^F \\ \frac{f_k(x) - L_k^F}{U_k^F - L_k^F} & \text{if } L_k^F \leq f_k(x) \leq U_k^F \\ 1 & \text{if } f_k(x) \geq U_k^F \end{cases} \quad (1.172)$$

**Step-VI:** Now neutrosophic optimization method for MOLP problem gives an equivalent linear programming problem as Model-I-AL and Model-I-BL as

**Model-I-AL,BL**

**(P1. 19)**

$$\text{Maximize } \alpha - \beta + \gamma \quad (1.173)$$

$$T_k(f_k(x)) \geq \alpha \quad (1.174)$$

$$I_k(f_k(x)) \geq \gamma \quad (1.175)$$

$$F_k(f_k(x)) \leq \beta \text{ for } k=1,2,3,\dots,p \quad (1.176)$$

$$\alpha + \beta + \gamma \leq 3, \quad (1.177)$$

$$\alpha \geq \beta, \quad (1.178)$$

$$\alpha \geq \gamma, \quad (1.179)$$

$$\alpha, \beta, \gamma \in [0, 1] \quad (1.180)$$

$$Ax \leq b, \quad (1.181)$$

$$x \geq 0 \quad (1.182)$$

Where  $A = [a_{ji}]_{q,n}$ ;  $X = (x_1, x_2, \dots, x_n)$ ;  $b = (b_1, b_2, \dots, b_q)^T$  for  $j = 1, 2, \dots, p; i = 1, 2, \dots, n$

Where in case of Model-I-AL we have considered Indeterminacy membership function as of decreasing sense and in Model-I-BL we have considered Indeterminacy membership function as of increasing sense.

Again Model-II-AL and Model-II-BL can be formulated as

### Model-II-AL,BL

#### (P1. 20)

$$\text{Maximize } \alpha - \beta - \gamma \quad (1.183)$$

$$T_k(f_k(x)) \geq \alpha \quad (1.184)$$

$$I_k(f_k(x)) \leq \gamma \quad (1.185)$$

$$F_k(f_k(x)) \leq \beta \text{ for } k = 1, 2, 3, \dots, p \quad (1.186)$$

$$\alpha + \beta + \gamma \leq 3, \quad (1.187)$$

$$\alpha \geq \beta, \quad (1.188)$$

$$\alpha \geq \gamma, \quad (1.189)$$

$$\alpha, \beta, \gamma \in [0, 1] \quad (1.190)$$

$$Ax \leq b, \quad (1.191)$$

$$x \geq 0 \quad (1.192)$$

Where  $A = [a_{ji}]_{q,n}$ ;  $X = (x_1, x_2, \dots, x_n)$ ;  $b = (b_1, b_2, \dots, b_q)^T$  for  $j = 1, 2, \dots, p; i = 1, 2, \dots, n$  Here

Here Model-II-AL, and Model-II-BL stand for neutrosophic algorithm with decreasing indeterminacy membership function and increasing indeterminacy membership function respectively. The above problems can be reduced to equivalent linear programming problem as

### Model-I-AL

#### (P1. 21)

$$\text{Maximize } \alpha - \beta + \gamma \quad (1.193)$$

Such that

$$f_k(x) + (U_k^T - L_k^T)\alpha \leq U_k^T \quad (1.194)$$

$$f_k(x) + (U_k^I - L_k^I)\gamma \leq U_k^I \quad (1.195)$$

$$f_k(x) - (U_k^F - L_k^F)\beta \leq L_k^F \quad (1.196)$$

$$\alpha + \beta + \gamma \leq 3, \quad (1.197)$$

$$\alpha \geq \beta, \quad (1.198)$$

$$\alpha \geq \gamma, \quad (1.199)$$

$$\alpha, \beta, \gamma \in [0, 1] \quad (1.200)$$

$$Ax \leq b, \quad (1.201)$$

$$x \geq 0 \quad (1.202)$$

Where  $A = [a_{ji}]_{q,n}$ ;  $X = (x_1, x_2, \dots, x_n)$ ;  $b = (b_1, b_2, \dots, b_q)^T$  for  $j = 1, 2, \dots, p; i = 1, 2, \dots, n$

And

### Model-I-BL

(P1. 22)

$$\text{Maximize } \alpha - \beta + \gamma \quad (1.203)$$

Such that

$$f_k(x) + (U_k^T - L_k^T)\alpha \leq U_k^T \quad (1.204)$$

$$f_k(x) - (U_k^I - L_k^I)\gamma \geq L_k^I \quad (1.205)$$

$$f_k(x) - (U_k^F - L_k^F)\beta \leq L_k^F \quad (1.206)$$

$$\alpha + \beta + \gamma \leq 3, \quad (1.207)$$

$$\alpha \geq \beta, \quad (1.208)$$

$$\alpha \geq \gamma, \quad (1.209)$$

$$\alpha, \beta, \gamma \in [0, 1] \quad (1.210)$$

$$Ax \leq b, \quad (1.211)$$

$$x \geq 0 \quad (1.212)$$

Where  $A = [a_{ji}]_{q,n}$ ;  $X = (x_1, x_2, \dots, x_n)$ ;  $b = (b_1, b_2, \dots, b_q)^T$  for  $j = 1, 2, \dots, p; i = 1, 2, \dots, n$

And

### Model-II-AL

#### (P1. 23)

$$\text{Maximize } \alpha - \beta - \gamma \quad (1.213)$$

Such that

$$f_k(x) + (U_k^T - L_k^T)\alpha \leq U_k^T \quad (1.214)$$

$$f_k(x) + (U_k^I - L_k^I)\gamma \geq U_k^I \quad (1.215)$$

$$f_k(x) - (U_k^F - L_k^F)\beta \leq L_k^F \quad (1.216)$$

$$\alpha + \beta + \gamma \leq 3, \quad (1.217)$$

$$\alpha \geq \beta, \quad (1.218)$$

$$\alpha \geq \gamma, \quad (1.219)$$

$$\alpha, \beta, \gamma \in [0, 1] \quad (1.220)$$

$$Ax \leq b, \quad (1.221)$$

$$x \geq 0 \quad (1.222)$$

Where  $A = [a_{ji}]_{q,n}$ ;  $X = (x_1, x_2, \dots, x_n)$ ;  $b = (b_1, b_2, \dots, b_q)^T$  for  $j = 1, 2, \dots, p; i = 1, 2, \dots, n$

And

### Model-II-BL

#### (P1. 24)

$$\text{Maximize } \alpha - \beta - \gamma \quad (1.223)$$

Such that

$$f_k(x) + (U_k^T - L_k^T)\alpha \leq U_k^T \quad (1.224)$$

$$f_k(x) - (U_k^I - L_k^I)\gamma \leq L_k^I \quad (1.225)$$

$$f_k(x) - (U_k^F - L_k^F)\beta \leq L_k^F \quad (1.226)$$

$$\alpha + \beta + \gamma \leq 3, \quad (1.227)$$



$$\alpha \geq \beta, \quad (1.228)$$

$$\alpha \geq \gamma, \quad (1.229)$$

$$\alpha, \beta, \gamma \in [0, 1] \quad (1.230)$$

$$Ax \leq b, \quad (1.231)$$

$$x \geq 0 \quad (1.232)$$

Where  $A = [a_{ji}]_{q,n}$ ;  $X = (x_1, x_2, \dots, x_n)$ ;  $b = (b_1, b_2, \dots, b_q)^T$  for  $j = 1, 2, \dots, p; i = 1, 2, \dots, n$

And

### Computational Algorithm 2 (Non Linear Membership Function)

Repeat step 1 to 4 as same as computational algorithm 1 and construct pay off matrix.

**Step-V:** Assumes that solutions so far computed by algorithm follow exponential function for Truth membership, hyperbolic membership function for Falsity membership and exponential function for Indeterminacy membership function (Model-I-AN, Model-I-BN) given as

$$T_k(f_k(x)) = \begin{cases} 0 & \text{if } f_k(x) \leq L_k^T \\ 1 - \exp\left\{-\psi \frac{U_k^T - f_k(x)}{U_k^T - L_k^T}\right\} & \text{if } L_k^T \leq f_k(x) \leq U_k^T \\ 1 & \text{if } f_k(x) \geq U_k^T \end{cases} \quad (1.233)$$

For Model-I,II-AN as

$$I_k(f_k(x)) = \begin{cases} 0 & \text{if } f_k(x) \leq L_k^I \\ \exp\left\{\frac{U_k^I - f_k(x)}{U_k^I - L_k^I}\right\} & \text{if } L_k^I \leq f_k(x) \leq U_k^I \\ 1 & \text{if } f_k(x) \geq U_k^I \end{cases} \quad (1.234)$$

For Model-I,II-BN as

$$I_k(f_k(x)) = \begin{cases} 0 & \text{if } f_k(x) \leq L_k^I \\ \exp\left\{\frac{f_k(x) - L_k^I}{U_k^I - L_k^I}\right\} & \text{if } L_k^I \leq f_k(x) \leq U_k^I \\ 1 & \text{if } f_k(x) \geq U_k^I \end{cases} \quad (1.235)$$

$$F_k(f_k(x)) = \begin{cases} 0 & \text{if } f_k(x) \leq L_k^F \\ \frac{1}{2} + \frac{1}{2} \tanh \left\{ \delta_k \left( f_k(x) - \frac{U_k^F + L_k^F}{2} \right) \right\} & \text{if } L_k^F \leq f_k(x) \leq U_k^F \\ 1 & \text{if } f_k(x) \geq U_k^F \end{cases} \quad (1.236)$$

**Step-VI:** Now neutrosophic optimization method for MOLP problem with exponential Truth membership, Hyperbolic falsity membership and exponential indeterminacy membership functions give the equivalent linear programming problem as

**Model-I-AN,**

**(P1. 25)**

$$\text{Maximize } \theta + \xi - \eta \quad (1.237)$$

Such that

$$f_k(x) + \frac{(U_k^T - L_k^T)\theta}{4} \leq U_k^T \quad (1.238)$$

$$f_k(x) - (U_k^I - L_k^I)\kappa \leq U_k^I \quad (1.239)$$

$$f_k(x) - \frac{\eta}{\delta_k} \leq \frac{U_k^F + L_k^F}{2} \quad (1.240)$$

$$\theta + \xi + \eta \leq 3, \quad (1.241)$$

$$\theta \geq \xi, \quad (1.242)$$

$$\theta \geq \eta, \quad (1.243)$$

$$\theta, \xi, \eta \in [0, 1] \quad (1.244)$$

$$Ax \leq b, \quad (1.245)$$

$$x \geq 0 \quad (1.246)$$

Where  $A = [a_{ji}]_{q,n}$ ;  $X = (x_1, x_2, \dots, x_n)$ ;  $b = (b_1, b_2, \dots, b_q)^T$  for  $j = 1, 2, \dots, p; i = 1, 2, \dots, n$

$$\theta = -\log(1 - \alpha), \quad (1.247)$$

$$\xi = \log \gamma, \quad (1.248)$$

$$\eta = \tanh^{-1}(2\beta - 1), \quad (1.249)$$

$$\psi = 4, \quad (1.250)$$

$$\delta_k = \frac{6}{U_k^F - L_k^F} \quad (1.251)$$

And

**Model-I-BN**

**(P1. 26)**

$$\text{Maximize } \theta + \xi - \eta \quad (1.252)$$

Such that

$$f_k(x) + \frac{(U_k^T - L_k^T)\theta}{4} \leq U_k^T \quad (1.253)$$

$$f_k(x) - (U_k^I - L_k^I)\kappa \geq L_k^I \quad (1.254)$$

$$f_k(x) - \frac{\eta}{\delta_k} \leq \frac{U_k^F + L_k^F}{2} \quad (1.255)$$

$$\theta + \xi + \eta \leq 3, \quad (1.256)$$

$$\theta \geq \xi, \quad (1.257)$$

$$\theta \geq \eta, \quad (1.258)$$

$$\theta, \xi, \eta \in [0, 1] \quad (1.259)$$

$$Ax \leq b, \quad (1.260)$$

$$x \geq 0 \quad (1.261)$$

Where  $A = [a_{ji}]_{q,n}$ ;  $X = (x_1, x_2, \dots, x_n)$ ;  $b = (b_1, b_2, \dots, b_q)^T$  for  $j = 1, 2, \dots, p; i = 1, 2, \dots, n$

$$\theta = -\log(1 - \alpha), \quad (1.262)$$

$$\xi = \log \gamma, \quad (1.263)$$

$$\eta = \tanh^{-1}(2\beta - 1), \quad (1.264)$$

$$\psi = 4, \quad (1.265)$$

$$\delta_k = \frac{6}{U_k^F - L_k^F} \quad (1.266)$$

**Model-II-AN,**

**(P1. 27)**

$$\text{Maximize } \theta - \xi - \eta \quad (1.267)$$

Such that

$$f_k(x) + \frac{(U_k^T - L_k^T)\theta}{4} \leq U_k^T \quad (1.268)$$

$$f_k(x) + (U_k^I - L_k^I)\kappa \geq U_k^I \quad (1.269)$$

$$f_k(x) - \frac{\eta}{\delta_k} \leq \frac{U_k^F + L_k^F}{2} \quad (1.270)$$

$$\theta + \xi + \eta \leq 3, \quad (1.271)$$

$$\theta \geq \xi, \quad (1.272)$$

$$\theta \geq \eta, \quad (1.273)$$

$$\theta, \xi, \eta \in [0, 1] \quad (1.274)$$

$$Ax \leq b, \quad (1.275)$$

$$x \geq 0 \quad (1.276)$$

Where  $A = [a_{ji}]_{q,n}$ ;  $X = (x_1, x_2, \dots, x_n)$ ;  $b = (b_1, b_2, \dots, b_q)^T$  for  $j = 1, 2, \dots, p; i = 1, 2, \dots, n$

$$\theta = -\log(1 - \alpha), \quad (1.277)$$

$$\xi = \log \gamma, \quad (1.278)$$

$$\eta = \tanh^{-1}(2\beta - 1), \quad (1.279)$$

$$\psi = 4, \quad (1.280)$$

$$\delta_k = \frac{6}{U_k^F - L_k^F} \quad (1.281)$$

**Model-II-BN,**

**(P1. 28)**

$$\text{Maximize } \theta - \xi - \eta \quad (1.282)$$

Such that

$$f_k(x) + \frac{(U_k^T - L_k^T)\theta}{4} \leq U_k^T \quad (1.283)$$

$$f_k(x) - (U_k^I - L_k^I)\kappa \leq L_k^I \quad (1.284)$$

$$f_k(x) - \frac{\eta}{\delta_k} \leq \frac{U_k^F + L_k^F}{2} \quad (1.285)$$

$$\theta + \xi + \eta \leq 3, \quad (1.286)$$

$$\theta \geq \xi, \quad (1.287)$$

$$\theta \geq \eta, \quad (1.288)$$

$$\theta, \xi, \eta \in [0, 1] \quad (1.289)$$

$$Ax \leq b, \quad (1.290)$$

$$x \geq 0 \quad (1.291)$$

Where  $A = [a_{ji}]_{q,n}$ ;  $X = (x_1, x_2, \dots, x_n)$ ;  $b = (b_1, b_2, \dots, b_q)^T$  for  $j = 1, 2, \dots, p; i = 1, 2, \dots, n$

$$\theta = -\log(1 - \alpha), \quad (1.292)$$

$$\xi = \log \gamma, \quad (1.293)$$

$$\eta = \tanh^{-1}(2\beta - 1), \quad (1.294)$$

$$\psi = 4, \quad (1.295)$$

$$\delta_k = \frac{6}{U_k^F - L_k^F} \quad (1.296)$$

The above crisp linear programming problems can be solved by LINGO Tool Box.

## 1.28 Production Planning Problem

Consider a park of six machine types whose capacities are to be devoted to production of three products. A current capacity portfolio is available, measured in machine hours for each machine capacity unit price according to machine type. Necessary data are summarized below in table 1.4.

**Table 1.4 Physical Parameter values**

Machine Type	Machine hours	Unit price (\$ 100 per hour)	Products		
			$x_1$	$x_2$	$x_3$
Milling Machine	1400	0.75	12	17	0

Lathe	1000	0.60	3	9	8
Grinder	1750	0.35	10	13	15
Jig Saw	1325	0.50	6	0	16
Drill Press	900	0.15	0	12	7
Band Saw	1075	0.65	9.5	9.5	4
Total capacity cost	\$ 4658.75				

Let  $x_1, x_2, x_3$  denote three products, then the complete mathematical formulation of the above mentioned problem as Multi-objective linear programming problem can be given as

**(P1. 29)**

$$\text{Maximize } f_1(x) = 50x_1 + 100x_2 + 17.5x_3 \text{ (profit)} \quad (1.297)$$

$$\text{Maximize } f_2(x) = 92x_1 + 75x_2 + 50x_3 \text{ (quality)} \quad (1.298)$$

$$\text{Maximize } f_3(x) = 25x_1 + 100x_2 + 75x_3 \text{ (worker satisfaction)} \quad (1.299)$$

Subject to

$$12x_1 + 17x_2 \leq 1400; \quad (1.300)$$

$$3x_1 + 9x_2 + 8x_3 \leq 1400; \quad (1.301)$$

$$10x_1 + 13x_2 + 15x_3 \leq 1750 \quad (1.302)$$

$$6x_1 + 16x_3 \leq 1325 \quad (1.303)$$

$$x_1, x_2, x_3 \geq 0 \quad (1.304)$$

**Table 1.5 Positive Ideal Solution**

	$f_1$	$f_2$	$f_3$
$Max f_1$	8041.14	10020.33	9319.25
$Max f_2$	5452.63	10950.59	5903.00
$Max f_3$	7983.60	10056.99	9355.90

**Table 1.6 Comparison of optimal solutions by IFO and NSO Technique**

Optimization Technique	Optimal Decision Variable $x_1^*, x_2^*, x_3^*$	Optimal Objective Function $f_1^*, f_2^*, f_3^*$	Sum of optimal objective values
Intuitionistic Fuzzy Optimization(IFO)	$x_1^* = 62.82;$ $x_2^* = 38.005;$ $x_3^* = 41.84$	$f_1^* = 7673.2;$ $f_2^* = 10721.81;$ $f_3^* = 8508.5$	26903.51
Proposed Neutrosophic Optimization(NSO) $\varepsilon_1, \xi_1 = 1294.255$ $\varepsilon_2, \xi_2 = 465.13$ $\varepsilon_3, \xi_3 = 1726.450$ Model-I-AL	$x_1^* = 79.99;$ $x_2^* = 7.073;$ $x_3^* = 42.611$	$f_1^* = 5452.630;$ $f_2^* = 10020.33;$ $f_3^* = 5903.0$	12375.96
Model-I-BL	$x_1^* = 68.89;$ $x_2^* = 25.09;$ $x_3^* = 45.30$	$f_1^* = 6746.855;$ $f_2^* = 465.13;$ $f_3^* = 7629.45$	14841.435
Model-II-AL	$x_1^* = 68.89;$ $x_2^* = 25.09;$ $x_3^* = 45.30$	$f_1^* = 6746.855;$ $f_2^* = 465.13;$ $f_3^* = 7629.45$	14841.435
Model-II-BL	$x_1^* = 79.99;$ $x_2^* = 7.07;$ $x_3^* = 42.62$	$f_1^* = 5452.63;$ $f_2^* = 10020.33;$ $f_3^* = 5903.0$	21375.96
Model-I-AN	$x_1^* = 66.58;$ $x_2^* = 22.05;$ $x_3^* = 43.95$	$f_1^* = 6303.59;$ $f_2^* = 9977.03;$ $f_3^* = 7166.53$	23447.15
Model-I-BN	$x_1^* = 64.088;$ $x_2^* = 30.74;$ $x_3^* = 46.422$	$f_1^* = 7090.533;$ $f_2^* = 10522.56;$ $f_3^* = 8157.639$	25770.732

Model-II-AN	$x_1^* = 64.088;$ $x_2^* = 30.74;$ $x_3^* = 46.42$	$f_1^* = 7090.533;$ $f_2^* = 10522.56;$ $f_3^* = 8157.639$	25770.732
Model-II-BN	$x_1^* = 66.58;$ $x_2^* = 22.06;$ $x_3^* = 43.96$	$f_1^* = 6303.89;$ $f_2^* = 9977.61;$ $f_3^* = 7167.44$	23448.94

Table 1.6 shows that neutrosophic optimization gives better result than intuitionistic fuzzy optimization.

### 1.29 Neutrosophic Optimization (NSO) Technique to solve Single-Objective Minimization Type Nonlinear Programming (SONLP) Problem

Let us consider a SONLP problem as

**(P1. 30)**

$$\text{Minimize } f(x) \tag{1.305}$$

$$g_j(x) \leq b_j \quad j = 1, 2, \dots, m \tag{1.306}$$

$$x \geq 0 \tag{1.307}$$

Usually constraint goals are considered as fixed quantity .But in real life problem, the constraint goal cannot be always exact. So we can consider the constraint goal for less than type constraints at least  $b_j$  and it may possible to extend to  $b_j + b_j^0$ . This fact seems to take the constraint goal as a NS and which will be more realistic descriptions than others. Then the NLP becomes NSO problem with neutrosophic resources, which can be described as follows

**(P1. 31)**

$$\text{Minimize } f(x) \tag{1.308}$$

$$g_j(x) \leq \tilde{b}_j^n \quad j = 1, 2, \dots, m \tag{1.309}$$

$$x \geq 0 \tag{1.310}$$

To solve the NSO (P1.31), following Werner's [118] and Angelov [3] we are presenting a solution procedure for SONSO problem (P1.31) as follows

**Step-1:** Following Werner's approach solve the single objective non-linear programming problem without tolerance in constraints (i.e  $g_j(x) \leq b_j$ ), with tolerance of acceptance in constraints (i.e  $g_j(x) \leq b_j + b_j^0$ ) by appropriate non-linear programming technique



Here they are

**(P1. 32)**

**Sub-problem-1**

$$\text{Minimize } f(x) \quad (1.311)$$

$$g_j(x) \leq b_j \quad j = 1, 2, \dots, m \quad (1.312)$$

$$x \geq 0 \quad (1.313)$$

**(P1. 33)**

**Sub-problem-2**

$$\text{Minimize } f(x) \quad (1.314)$$

$$g_j(x) \leq b_j + b_j^0, \quad j = 1, 2, \dots, m \quad (1.315)$$

$$x \geq 0 \quad (1.316)$$

we may get optimal solutions  $x^* = x^1, f(x^*) = f(x^1)$  and  $x^* = x^2, f(x^*) = f(x^2)$  for sub-problem 1 and 2 respectively.

**Step-2:** From the result of step 1 we now find the lower bound and upper bound of objective functions [Fig.-1.1]. If  $U_{f(x)}^T, U_{f(x)}^I, U_{f(x)}^F$  be the upper bounds of truth, indeterminacy, falsity function for the objective respectively and  $L_{f(x)}^T, L_{f(x)}^I, L_{f(x)}^F$  be the lower bound of truth, indeterminacy, falsity membership functions of objective respectively then

$$U_{f(x)}^T = \max \{f(x^1), f(x^2)\}, \quad (1.317)$$

$$L_{f(x)}^T = \min \{f(x^1), f(x^2)\}, \quad (1.318)$$

for Model-I,II-AL,AN

$$L_{f(x)}^I = L_{f(x)}^T \quad \text{and} \quad U_{f(x)}^I = L_{f(x)}^T + s(U_{f(x)}^T - L_{f(x)}^T) \quad (1.319)$$

$$U_{f(x)}^F = U_{f(x)}^T \quad \text{and} \quad L_{f(x)}^F = L_{f(x)}^T + t(U_{f(x)}^T - L_{f(x)}^T); \quad (1.320)$$

for Model-I,II-BL,BN

$$U_k^F = U_k^T = U_k^I$$

$$L_k^F = L_k^T - s(U_k^T - L_k^T)$$

$$L_k^I = L_k^T - t(U_k^T - L_k^T)$$

Here  $t, s$  are predetermined real numbers in  $(0,1)$

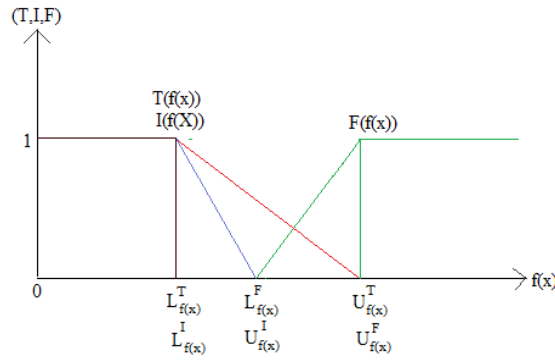

**Fig.-1.1 Rough Sketch of Lower and Upper bounds of Truth, Indeterminacy and Falsity Membership Functions of Objective of (P1.31)**

The initial neutrosophic model (Model -I)with aspiration levels of objectives can be formulated as

**(P1. 34)**

Find  $x$  (1.321)

So as to satisfy

$$f(x) \leq^n L_{f(x)}^T \text{ with tolerance } (U_{f(x)}^T - L_{f(x)}^T) \text{ for degree of truth membership} \quad (1.322)$$

$$f(x) \leq^n L_{f(x)}^I \text{ with tolerance } (U_{f(x)}^I - L_{f(x)}^I) \text{ for degree of indeterminacy membership} \quad (1.323)$$

$$f(x) \geq^n U_{f(x)}^F \text{ with tolerance } (U_{f(x)}^F - L_{f(x)}^F) \text{ for degree of falsity membership} \quad (1.324)$$

$$g_j(x) \leq^n b_j \text{ with tolerance } b_j^0 \text{ for degree of truth membership} \quad (1.325)$$

$$g_j(x) \leq^n b_j \text{ with tolerance } (\xi_{g_j(x)}) \text{ for degree of indeterminacy membership} \quad (1.326)$$

$$g_j(x) \geq^n b_j + b_j^0 \text{ with tolerance } ((b_j + b_j^0) - (b_j + \varepsilon_{g_j(x)})) \text{ for degree of falsity membership} \quad (1.327)$$

for  $j = 1, 2, \dots, m$ ,  $\varepsilon_{g_j(x)} = t(U_{g_j(x)}^T - L_{g_j(x)}^T)$ ;  $t \in (0, 1)$  and  $\xi_{g_j(x)} = s(U_{g_j(x)}^I - L_{g_j(x)}^I)$ ;  $s \in (0, 1)$

and for Mode-II it can be formulated as

**(P1. 35)**

Find  $x$  (1.328)

So as to satisfy

$$f(x) \leq^n L_{f(x)}^T \text{ with tolerance } (U_{f(x)}^T - L_{f(x)}^T) \text{ for degree of truth membership} \quad (1.329)$$

$$f(x) \geq^n U_{f(x)}^I \text{ with tolerance } (U_{f(x)}^I - L_{f(x)}^I) \text{ for degree of indeterminacy membership (1.330)}$$

$$f(x) \geq^n U_{f(x)}^F \text{ with tolerance } (U_{f(x)}^F - L_{f(x)}^F) \text{ for degree of falsity membership (1.331)}$$

$$g_j(x) \leq^n b_j \text{ with tolerance } b_j^0 \text{ for degree of truth membership (1.332)}$$

$$g_j(x) \geq^n (b_j + \xi_{g_j(x)}) \text{ with tolerance } (\xi_{g_j(x)}) \text{ for degree of indeterminacy membership (1.333)}$$

$$g_j(x) \geq^n b_j + b_j^0 \text{ with tolerance } ((b_j + b_j^0) - (b_j + \varepsilon_{g_j(x)})) \text{ for degree of falsity membership (1.334)}$$

$$\text{For } j = 1, 2, \dots, m, \varepsilon_{g_j(x)} = t(U_{g_j(x)}^T - L_{g_j(x)}^T); t \in (0, 1) \text{ (1.335)}$$

$$\text{and } \xi_{g_j(x)} = s(U_{g_j(x)}^T - L_{g_j(x)}^T); s \in (0, 1) \text{ (1.336)}$$

Here ' $\geq^n$ ' denotes inequality in neutrosophic sense.

**Step-3:** In this step we calculate linear membership for truth, indeterminacy and falsity membership functions of objective as follows

$$T_{f(x)}(f(x)) = \begin{cases} 1 & \text{if } f(x) \leq L_{f(x)}^T \\ \left( \frac{U_{f(x)}^T - f(x)}{U_{f(x)}^T - L_{f(x)}^T} \right) & \text{if } L_{f(x)}^T \leq f(x) \leq U_{f(x)}^T \\ 0 & \text{if } f(x) \geq U_{f(x)}^T \end{cases} \quad (1.337)$$

For Model-I,II-AL

$$I_{f(x)}(f(x)) = \begin{cases} 1 & \text{if } f(x) \leq L_{f(x)}^I \\ \left( \frac{U_{f(x)}^I - f(x)}{U_{f(x)}^I - L_{f(x)}^I} \right) & \text{if } L_{f(x)}^I \leq f(x) \leq U_{f(x)}^I \\ 0 & \text{if } f(x) \geq U_{f(x)}^I \end{cases} \quad (1.338)$$

For Model-I,II-BL

$$I_{f(x)}(f(x)) = \begin{cases} 1 & \text{if } f(x) \geq U_{f(x)}^I \\ \left( \frac{f(x) - L_{f(x)}^I}{U_{f(x)}^I - L_{f(x)}^I} \right) & \text{if } L_{f(x)}^I \leq f(x) \leq U_{f(x)}^I \\ 0 & \text{if } f(x) \leq L_{f(x)}^I \end{cases} \quad (1.339)$$

$$F_{f(x)}(f(x)) = \begin{cases} 0 & \text{if } f(x) \leq L_{f(x)}^F \\ \frac{f(x) - L_{f(x)}^F}{U_{f(x)}^F - L_{f(x)}^F} & \text{if } L_{f(x)}^F \leq f(x) \leq U_{f(x)}^F \\ 1 & \text{if } f(x) \geq U_{f(x)}^F \end{cases} \quad (1.340)$$

and exponential and hyperbolic membership for truth, indeterminacy and falsity membership functions as follows

$$T_{f(x)}(f(x)) = \begin{cases} 1 & \text{if } f(x) \leq L_{f(x)}^T \\ 1 - \exp\left\{-\psi\left(\frac{U_{f(x)}^T - f(x)}{U_{f(x)}^T - L_{f(x)}^T}\right)\right\} & \text{if } L_{f(x)}^T \leq f(x) \leq U_{f(x)}^T \\ 0 & \text{if } f(x) \geq U_{f(x)}^T \end{cases} \quad (1.341)$$

For Model-I,II-AN

$$I_{f(x)}(f(x)) = \begin{cases} 1 & \text{if } f(x) \leq L_{f(x)}^I \\ \exp\left\{\frac{U_{f(x)}^I - f(x)}{U_{f(x)}^I - L_{f(x)}^I}\right\} & \text{if } L_{f(x)}^I \leq f(x) \leq U_{f(x)}^I \\ 0 & \text{if } f(x) \geq U_{f(x)}^I \end{cases} \quad (1.342)$$

For Model-I,II-BN

$$I_{f(x)}(f(x)) = \begin{cases} 1 & \text{if } f(x) \geq U_{f(x)}^I \\ \exp\left\{\frac{f(x) - L_{f(x)}^I}{U_{f(x)}^I - L_{f(x)}^I}\right\} & \text{if } L_{f(x)}^I \leq f(x) \leq U_{f(x)}^I \\ 0 & \text{if } f(x) \leq L_{f(x)}^I \end{cases} \quad (1.343)$$

$$F_{f(x)}(f(x)) = \begin{cases} 0 & \text{if } f(x) \leq L_{f(x)}^F \\ \frac{1}{2} + \frac{1}{2} \tanh\left\{\left(f(x) - \frac{U_{f(x)}^F + L_{f(x)}^F}{2}\right)\tau_{f(x)}\right\} & \text{if } L_{f(x)}^F \leq f(x) \leq U_{f(x)}^F \\ 1 & \text{if } f(x) \geq U_{f(x)}^F \end{cases} \quad (1.344)$$

**Step-4:** In this step using linear, exponential and hyperbolic function for truth, indeterminacy and falsity membership functions, we may calculate membership function for constraints as follows

$$T_{g_j(x)}(g_j(x)) = \begin{cases} 1 & \text{if } g_j(x) \leq b_j \\ \left( \frac{b_j + b_j^0 - g_j(x)}{b_j^0} \right) & \text{if } b_j \leq g_j(x) \leq b_j + b_j^0 \\ 0 & \text{if } g_j(x) \geq b_j^0 \end{cases} \quad (1.345)$$

For Model-I,II-AL

$$I_{g_j(x)}(g_j(x)) = \begin{cases} 1 & \text{if } g_j(x) \leq b_j \\ \frac{(b_j + \xi_{g_j(x)}) - g_j(x)}{\xi_{g_j(x)}} & \text{if } b_j \leq g_j(x) \leq b_j + \xi_{g_j(x)} \\ 0 & \text{if } g_j(x) \geq b_j + \xi_{g_j(x)} \end{cases} \quad (1.346)$$

For Model-I,II-BL

$$I_{g_j(x)}(g_j(x)) = \begin{cases} 1 & \text{if } g_j(x) \geq b_j + b_j^0 \\ \frac{g_j(x) - (b_j + \xi_{g_j(x)})}{b_j^0 - \xi_{g_j(x)}} & \text{if } b_j + \xi_{g_j(x)} \leq g_j(x) \leq b_j + b_j^0 \\ 0 & \text{if } g_j(x) \leq b_j + \xi_{g_j(x)} \end{cases} \quad (1.347)$$

$$F_{g_j(x)}(g_j(x)) = \begin{cases} 0 & \text{if } g_j(x) \leq b_j + \varepsilon_{g_j(x)} \\ \frac{g_j(x) - b_j - \varepsilon_{g_j(x)}}{b_j^0 - \varepsilon_{g_j(x)}} & \text{if } b_j + \varepsilon_{g_j(x)} \leq g_j(x) \leq b_j + b_j^0 \\ 1 & \text{if } g_j(x) \geq b_j + b_j^0 \end{cases} \quad (1.348)$$

where for  $j=1,2,\dots,m$   $0 < \varepsilon_{g_j(x)}, \xi_{g_j(x)} < b_j^0$ . and

$$T_{g_j(x)}(g_j(x)) = \begin{cases} 1 & \text{if } g_j(x) \leq b_j \\ 1 - \exp \left\{ -\psi \left( \frac{U_{g_j(x)}^T - g_j(x)}{U_{g_j(x)}^T - L_{g_j(x)}^T} \right) \right\} & \text{if } b_j \leq g_j(x) \leq b_j + b_j^0 \\ 0 & \text{if } g_j(x) \geq b_j + b_j^0 \end{cases} \quad (1.349)$$

For Model-I,II-AN

$$I_{g_j(x)}(g_j(x)) = \begin{cases} 1 & \text{if } g_j(x) \leq b_j \\ \exp \left\{ \frac{(b_j + \xi_{g_j(x)}) - g_j(x)}{\xi_{g_j(x)}} \right\} & \text{if } b_j \leq g_j(x) \leq b_j + \xi_{g_j(x)} \\ 0 & \text{if } g_j(x) \geq b_j + \xi_{g_j(x)} \end{cases} \quad (1.350)$$

For Model-I,II-BN

$$I_{g_j(x)}(g_j(x)) = \begin{cases} 1 & \text{if } g_j(x) \geq b_j + b_j^0 \\ \exp\left\{\frac{g_j(x) - (b_j + \xi_{g_j(x)})}{(b_j^0 - \xi_{g_j(x)})}\right\} & \text{if } b_j + \xi_{g_j(x)} \leq g_j(x) \leq b_j + b_j^0 \\ 0 & \text{if } g_j(x) \leq b_j + \xi_{g_j(x)} \end{cases} \quad (1.351)$$

$$F_{g_j(x)}(g_j(x)) = \begin{cases} 0 & \text{if } g_j(x) \leq b_j + \varepsilon_{g_j(x)} \\ \frac{1}{2} + \frac{1}{2} \tanh\left\{\left(g_j(x) - \frac{2b_j + b_j^0 + \varepsilon_{g_j(x)}}{2}\right)\tau_{g_j(x)}\right\} & \text{if } b_j + \varepsilon_{g_j(x)} \leq g_j(x) \leq b_j + b_j^0 \\ 1 & \text{if } g_j(x) \geq b_j + b_j^0 \end{cases} \quad (1.352)$$

where  $\psi, \tau$  are non-zero parameters prescribed by the decision maker and for

$$j = 1, 2, \dots, m \quad 0 < \varepsilon_{g_j(x)}, \xi_{g_j(x)} < b_j^0.$$

**Step-5:** Now using NSO for single objective optimization technique the optimization problem (P1.34) and (P1.35) can be formulated as

**(P1. 36)**

**Model-I-AN, BN**

$$\text{Maximize } (\alpha + \gamma - \beta) \quad (1.353)$$

Such that

$$T_{f(x)}(x) \geq \alpha; \quad (1.354)$$

$$T_{g_j}(x) \geq \alpha; \quad (1.355)$$

$$I_{f(x)}(x) \geq \gamma; \quad (1.356)$$

$$I_{g_j}(x) \geq \gamma; \quad (1.357)$$

$$F_{f(x)}(x) \leq \beta; \quad (1.358)$$

$$F_{g_j}(x) \leq \beta; \quad (1.359)$$

$$\alpha + \beta + \gamma \leq 3; \quad (1.360)$$

$$\alpha \geq \beta; \alpha \geq \gamma; \quad (1.361)$$

$$\alpha, \beta, \gamma \in [0, 1] \quad (1.362)$$

In case of Model-I-AN and Model-I-BN we will consider indeterminacy membership function in decreasing sense and increasing sense respectively.

**(P1. 37)**

**Model-II-AN,BN**

$$\text{Maximize } (\alpha - \gamma - \beta) \quad (1.363)$$

Subject to

$$T_{f(x)}(x) \geq \alpha; \quad (1.364)$$

$$T_{g_j}(x) \geq \alpha; \quad (1.365)$$

$$I_{f(x)}(x) \leq \gamma; \quad (1.366)$$

$$I_{g_j}(x) \leq \gamma; \quad (1.367)$$

$$F_{f(x)}(x) \leq \beta; \quad (1.368)$$

$$F_{g_j}(x) \leq \beta; \quad (1.369)$$

$$\alpha + \beta + \gamma \leq 3; \quad (1.370)$$

$$\alpha \geq \beta; \alpha \geq \gamma; \quad (1.371)$$

$$\alpha, \beta, \gamma \in [0,1] \quad (1.372)$$

In case of Model-II-A and Model-II-B we will consider indeterminacy membership function in decreasing sense and increasing sense respectively.

Now the above problem (Model-I) (P1.36) can be simplified to following crisp linear programming problem for linear membership function as

**Model-I-AL**

**(P1. 38)**

$$\text{Maximize } (\alpha + \gamma - \beta) \quad (1.373)$$

$$\text{such that } f(x) + (U_{f(x)}^T - L_{f(x)}^T) \cdot \alpha \leq U_{f(x)}^T; \quad (1.374)$$

$$f(x) + (U_{f(x)}^I - L_{f(x)}^I) \cdot \gamma \geq U_{f(x)}^I; \quad (1.375)$$

$$f(x) - (U_{f(x)}^F - L_{f(x)}^F) \cdot \beta \leq L_{f(x)}^F; \quad \text{for } k = 1, 2, \dots, p \quad (1.376)$$

$$\alpha + \beta + \gamma \leq 3; \quad (1.377)$$

$$\alpha \geq \beta; \quad (1.378)$$

$$\alpha \geq \gamma; \quad (1.379)$$

$$\alpha, \beta, \gamma \in [0,1]; \quad (1.380)$$

$$g_j(x) \leq b_j, \quad (1.381)$$

$$x \geq 0, \quad (1.382)$$

### Model-I-BL

#### (P1. 39)

$$\text{Maximize } (\alpha + \gamma - \beta) \quad (1.383)$$

$$\text{such that } f(x) + (U_{f(x)}^T - L_{f(x)}^T) \cdot \alpha \leq U_{f(x)}^T; \quad (1.384)$$

$$f(x) - (U_{f(x)}^L - L_{f(x)}^L) \cdot \gamma \leq L_{f(x)}^L; \quad (1.385)$$

$$f(x) - (U_{f(x)}^F - L_{f(x)}^F) \cdot \beta \leq L_{f(x)}^F; \quad \text{for } k = 1, 2, \dots, p \quad (1.386)$$

$$\alpha + \beta + \gamma \leq 3; \quad (1.387)$$

$$\alpha \geq \beta; \quad (1.388)$$

$$\alpha \geq \gamma; \quad (1.389)$$

$$\alpha, \beta, \gamma \in [0,1]; \quad (1.390)$$

$$g_j(x) \leq b_j, \quad (1.391)$$

$$x \geq 0, \quad (1.392)$$

and for nonlinear membership function as

### Model-I-AN

#### (P1. 40)

$$\text{Maximize } (\theta + \kappa - \eta) \quad (1.393)$$

Such that

$$f(x) + \theta \frac{(U_{f(x)}^T - L_{f(x)}^T)}{\psi} \leq U_{f(x)}^T; \quad (1.394)$$

$$f(x) + \kappa \xi_{f(x)} \leq L_{f(x)}^T + \xi_{f(x)}; \quad (1.395)$$

$$f(x) + \frac{\eta}{\tau_{f(x)}} \leq \frac{U_{f(x)}^T + L_{f(x)}^T + \varepsilon_{f(x)}}{2}; \quad (1.396)$$



$$g_j(x) + \theta \frac{b_j^0}{\psi} \leq b_j + b_j^0; \quad (1.397)$$

$$g_j(x) + \kappa \xi_{g_j(x)} \leq b_j^0 + \xi_{g_j(x)}; \quad (1.398)$$

$$g_j(x) + \frac{\eta}{\tau_{g_j(x)}} \leq \frac{2b_j + b_j^0 + \varepsilon_{g_j(x)}}{2}; \quad (1.399)$$

$$\theta + \kappa + \eta \leq 3; \quad (1.400)$$

$$\theta \geq \kappa; \quad (1.401)$$

$$\theta \geq \eta; \quad (1.402)$$

$$\theta, \kappa, \eta \in [0, 1] \quad (1.403)$$

Where

$$\theta = -\ln(1 - \alpha); \quad (1.404)$$

$$\psi = 4; \quad (1.405)$$

$$\tau_{f(x)} = \frac{6}{(U_{f(x)}^F - L_{f(x)}^F)}; \quad (1.406)$$

$$\tau_{g_j(x)} = \frac{6}{(b_j^0 - \varepsilon_j)}, \text{ for } j = 1, 2, \dots, m \quad (1.407)$$

$$\kappa = \ln \gamma; \quad (1.408)$$

$$\eta = \tanh^{-1}(2\beta - 1). \quad (1.409)$$

### Model-I-BN

(P1. 41)

$$\text{Maximize } (\theta + \kappa - \eta) \quad (1.410)$$

Such that

$$f(x) + \theta \frac{(U_{f(x)}^T - L_{f(x)}^T)}{\psi} \leq U_{f(x)}^T; \quad (1.411)$$

$$f(x) + \kappa (U_{f(x)}^T - L_{f(x)}^T - \xi_{f(x)}) \geq L_{f(x)}^T + \xi_{f(x)}; \quad (1.412)$$

$$f(x) + \frac{\eta}{\tau_{f(x)}} \leq \frac{U_{f(x)}^T + L_{f(x)}^T + \varepsilon_{f(x)}}{2}; \quad (1.413)$$

$$g_j(x) + \theta \frac{b_j^0}{\psi} \leq b_j + b_j^0; \quad (1.414)$$

$$g_j(x) + \kappa \xi_{g_j(x)} \leq b_j^0 + \xi_{g_j(x)}; \quad (1.415)$$

$$g_j(x) + \frac{\eta}{\tau_{g_j(x)}} \leq \frac{2b_j + b_j^0 + \varepsilon_{g_j(x)}}{2}; \quad (1.416)$$

$$\theta + \kappa + \eta \leq 3; \quad (1.417)$$

$$\theta \geq \kappa; \quad (1.418)$$

$$\theta \geq \eta; \quad (1.419)$$

$$\theta, \kappa, \eta \in [0, 1] \quad (1.420)$$

Where

$$\theta = -\ln(1 - \alpha); \quad (1.421)$$

$$\psi = 4; \quad (1.422)$$

$$\tau_{f(x)} = \frac{6}{(U_{f(x)}^F - L_{f(x)}^F)}; \quad (1.423)$$

$$\tau_{g_j(x)} = \frac{6}{(b_j^0 - \varepsilon_j)}, \text{ for } j = 1, 2, \dots, m \quad (1.424)$$

$$\kappa = \ln \gamma; \quad (1.425)$$

$$\eta = \tanh^{-1}(2\beta - 1). \quad (1.426)$$

Again the problem (Model-II) (P1.37) can be reduced to following crisp linear programming problem for linear membership function as

#### Model-II-AL

##### (P1. 42)

$$\text{Maximize } (\alpha - \beta - \gamma) \quad (1.427)$$

$$\text{such that } f(x) + (U_{f(x)}^T - L_{f(x)}^T) \cdot \alpha \leq U_{f(x)}^T; \quad (1.428)$$

$$f(x) + (U_{f(x)}^I - L_{f(x)}^I) \cdot \gamma \leq U_{f(x)}^I; \quad (1.429)$$

$$f(x) - (U_{f(x)}^F - L_{f(x)}^F) \cdot \beta \leq L_{f(x)}^F; \text{ for } k = 1, 2, \dots, p \quad (1.430)$$

$$\alpha + \beta + \gamma \leq 3; \quad (1.431)$$

$$\alpha \geq \beta; \quad (1.432)$$

$$\alpha \geq \gamma; \quad (1.433)$$

$$\alpha, \beta, \gamma \in [0, 1]; \quad (1.434)$$

$$g_j(x) \leq b_j, \quad (1.435)$$

$$x \geq 0, \quad (1.436)$$

### Model-II-BL

#### (P1. 43)

$$\text{Maximize } (\alpha - \beta - \gamma) \quad (1.437)$$

$$\text{such that } f(x) + (U_{f(x)}^T - L_{f(x)}^T) \cdot \alpha \leq U_{f(x)}^T; \quad (1.438)$$

$$f(x) - (U_{f(x)}^L - L_{f(x)}^L) \cdot \gamma \geq L_{f(x)}^L; \quad (1.439)$$

$$f(x) - (U_{f(x)}^F - L_{f(x)}^F) \cdot \beta \leq L_{f(x)}^F; \quad \text{for } k = 1, 2, \dots, p \quad (1.440)$$

$$\alpha + \beta + \gamma \leq 3; \quad (1.441)$$

$$\alpha \geq \beta; \quad (1.442)$$

$$\alpha \geq \gamma; \quad (1.443)$$

$$\alpha, \beta, \gamma \in [0, 1]; \quad (1.444)$$

$$g_j(x) \leq b_j, \quad (1.445)$$

$$x \geq 0, \quad (1.446)$$

and for nonlinear membership function as

### Model-II-AN

#### (P1. 44)

$$\text{Maximize } (\theta - \kappa - \eta) \quad (1.447)$$

Such that

$$f(x) + \theta \frac{(U_{f(x)}^T - L_{f(x)}^T)}{\psi} \leq U_{f(x)}^T; \quad (1.448)$$

$$f(x) + \kappa \xi_{f(x)} \geq L_{f(x)}^T + \xi_{f(x)}; \quad (1.449)$$

$$f(x) + \frac{\eta}{\tau_{f(x)}} \leq \frac{U_{f(x)}^T + L_{f(x)}^T + \varepsilon_{f(x)}}{2}; \quad (1.450)$$

$$g_j(x) + \theta \frac{b_j^0}{\psi} \leq b_j + b_j^0; \quad (1.451)$$

$$g_j(x) + \kappa \xi_{g_j(x)} \leq b_j^0 + \xi_{g_j(x)}; \quad (1.452)$$

$$g_j(x) + \frac{\eta}{\tau_{g_j(x)}} \leq \frac{2b_j + b_j^0 + \varepsilon_{g_j(x)}}{2}; \quad (1.453)$$

$$\theta + \kappa + \eta \leq 3; \quad (1.454)$$

$$\theta \geq \kappa; \quad (1.455)$$

$$\theta \geq \eta; \quad (1.456)$$

$$\theta, \kappa, \eta \in [0, 1] \quad (1.457)$$

Where

$$\theta = -\ln(1 - \alpha); \quad (1.458)$$

$$\psi = 4; \quad (1.459)$$

$$\tau_{f(x)} = \frac{6}{(U_{f(x)}^F - L_{f(x)}^F)}; \quad (1.460)$$

$$\tau_{g_j(x)} = \frac{6}{(b_j^0 - \varepsilon_j)}, \text{ for } j = 1, 2, \dots, m \quad (1.461)$$

$$\kappa = \ln \gamma; \quad (1.462)$$

$$\eta = \tanh^{-1}(2\beta - 1). \quad (1.463)$$

## Model-II-BN

### (P1. 45)

$$\text{Maximize } (\theta - \kappa - \eta) \quad (1.464)$$

Such that

$$f(x) + \theta \frac{(U_{f(x)}^T - L_{f(x)}^T)}{\psi} \leq U_{f(x)}^T; \quad (1.465)$$

$$f(x) + \kappa (U_{f(x)}^T - L_{f(x)}^T - \xi_{f(x)}) \leq L_{f(x)}^T + \xi_{f(x)}; \quad (1.466)$$

$$f(x) + \frac{\eta}{\tau_{f(x)}} \leq \frac{U_{f(x)}^T + L_{f(x)}^T + \varepsilon_{f(x)}}{2}; \quad (1.467)$$

$$g_j(x) + \theta \frac{b_j^0}{\psi} \leq b_j + b_j^0; \quad (1.468)$$

$$g_j(x) + \kappa \xi_{g_j(x)} \leq b_j^0 + \xi_{g_j(x)}; \quad (1.469)$$

$$g_j(x) + \frac{\eta}{\tau_{g_j(x)}} \leq \frac{2b_j + b_j^0 + \varepsilon_{g_j(x)}}{2}; \quad (1.470)$$

$$\theta + \kappa + \eta \leq 3; \quad (1.471)$$

$$\theta \geq \kappa; \quad (1.472)$$

$$\theta \geq \eta; \quad (1.473)$$

$$\theta, \kappa, \eta \in [0, 1] \quad (1.474)$$

Where

$$\theta = -\ln(1 - \alpha); \quad (1.475)$$

$$\psi = 4; \quad (1.476)$$

$$\tau_{f(x)} = \frac{6}{(U_{f(x)}^F - L_{f(x)}^F)}; \quad (1.477)$$

$$\tau_{g_j(x)} = \frac{6}{(b_j^0 - \varepsilon_j)}, \text{ for } j = 1, 2, \dots, m \quad (1.478)$$

$$\kappa = \ln \gamma; \quad (1.479)$$

$$\eta = \tanh^{-1}(2\beta - 1). \quad (1.480)$$

All these crisp nonlinear programming problems (P1.38-P1.45) can be solved by appropriate mathematical algorithm.

### 1.30 Neutrosophic Optimization Technique to solve Minimization Type Multi-Objective Non-linear Programming Problem for Linear Membership Function

A non-linear multi-objective optimization problem is of the form

**(P1. 46)**

$$\text{Minimize } \{f_1(x), f_2(x), \dots, f_p(x)\} \quad (1.481)$$

$$g_j(x) \leq b_j, \quad j = 1, 2, \dots, q \quad (1.482)$$

Now the decision set  $\tilde{D}^n$ , a conjunction of neutrosophic objectives and constraints is defined

$$\text{as } \tilde{D}^n = \left( \bigcap_{k=1}^p \tilde{G}_k^n \right) \cap \left( \bigcap_{j=1}^q \tilde{C}_j^n \right) = \{x, T_{\tilde{D}^n}(x), I_{\tilde{D}^n}(x), F_{\tilde{D}^n}(x)\}$$

(1.483)

Here

$$T_{\tilde{D}^n}(x) = \min \left\{ T_{\tilde{G}_1^n}(x), T_{\tilde{G}_2^n}(x), \dots, T_{\tilde{G}_p^n}(x); T_{\tilde{C}_1^n}(x), T_{\tilde{C}_2^n}(x), \dots, T_{\tilde{C}_p^n}(x) \right\} \text{ for all } x \in X \quad (1.484)$$

$$I_{\tilde{D}^n}(x) = \min \left\{ I_{\tilde{G}_1^n}(x), I_{\tilde{G}_2^n}(x), \dots, I_{\tilde{G}_p^n}(x); I_{\tilde{C}_1^n}(x), I_{\tilde{C}_2^n}(x), \dots, I_{\tilde{C}_p^n}(x) \right\} \text{ for all } x \in X \quad (1.485)$$

$$F_{\tilde{D}^n}(x) = \min \left\{ F_{\tilde{G}_1^n}(x), F_{\tilde{G}_2^n}(x), \dots, F_{\tilde{G}_p^n}(x); F_{\tilde{C}_1^n}(x), F_{\tilde{C}_2^n}(x), \dots, F_{\tilde{C}_p^n}(x) \right\} \text{ for all } x \in X \quad (1.486)$$

where  $T_{\tilde{D}^n}(x), I_{\tilde{D}^n}(x), F_{\tilde{D}^n}(x)$  are Truth membership function, Indeterminacy membership function, Falsity membership function of Neutrosophic decision set respectively. Now using the definition of Smarandache's Intersection the problem (P1.46) is transferred to the nonlinear programming problem as

Model-I-A,B

**(P1. 47)**

$$\text{Maximize } \alpha \quad (1.487)$$

$$\text{Minimize } \beta \quad (1.488)$$

$$\text{Maximize } \gamma \quad (1.489)$$

Such that

$$T_{\tilde{G}_k^n}(x) \geq \alpha \quad (1.490)$$

$$T_{\tilde{C}_j^n}(x) \geq \alpha \quad (1.491)$$

$$I_{\tilde{G}_j^n}(x) \geq \gamma \quad (1.492)$$

$$I_{\tilde{C}_j^n}(x) \geq \gamma \quad (1.493)$$

$$F_{\tilde{G}_k^n}(x) \leq \beta \quad (1.494)$$

$$F_{\tilde{C}_j^n}(x) \leq \beta \quad (1.495)$$

$$\alpha + \beta + \gamma \leq 3; \quad (1.496)$$

$$\alpha \geq \beta, \quad (1.497)$$

$$\alpha \geq \gamma \quad (1.498)$$

$$\alpha, \beta, \gamma \in [0,1] \quad (1.499)$$

In Model-I-A we will consider indeterminacy function as decreasing sense and in Model-I-B we will consider indeterminacy membership function as increasing sense.

Again in real world practical problem a decision maker needs to minimize hesitancy function. So the nonlinear programming problem can be formulated as

**Model-II-A,B**

**(P1. 48)**

$$\text{Maximize } \alpha \quad (1.500)$$

$$\text{Minimize } \beta \quad (1.501)$$

$$\text{Minimize } \gamma \quad (1.502)$$

Such that

$$T_{\tilde{G}_k^n}(x) \geq \alpha \quad (1.503)$$

$$T_{\tilde{C}_j^n}(x) \geq \alpha \quad (1.504)$$

$$I_{\tilde{G}_j^n}(x) \leq \gamma \quad (1.505)$$

$$I_{\tilde{C}_j^n}(x) \leq \gamma \quad (1.506)$$

$$F_{\tilde{G}_k^n}(x) \leq \beta \quad (1.507)$$

$$F_{\tilde{C}_j^n}(x) \leq \beta \quad (1.508)$$

$$\alpha + \beta + \gamma \leq 3; \quad (1.509)$$

$$\alpha \geq \beta, \quad (1.510)$$

$$\alpha \geq \gamma \quad (1.511)$$

$$\alpha, \beta, \gamma \in [0,1]$$

In Model-II-A we will consider indeterminacy function as decreasing sense and in Model-II-B we will consider indeterminacy membership function as increasing sense.

Now this non-linear programming problem (P1.47,P1.48) can be easily solved by appropriate mathematical algorithm to give solution of multi-objective linear programming problem (P1.46) by neutrosophic optimization approach.

## Computational Algorithm

**Step-1** Solve the MONLP(P1.46) as a single objective non-linear problem  $p$  times for each problem by taking one of the objectives at a time and ignoring the others. These solution are known as ideal solutions. Let  $x^k$  be the respective optimal solution for the  $k$  th different objective and evaluate each objective values for all these  $k$  th optimal solution.

**Step-2** From the result of Step-1,determine the corresponding values for every objective for each derived solution .With the values of all objectives at each ideal solutions, pay-off matrix can be formulated as follows

$$\begin{bmatrix} f_1^*(x^1) & f_2(x^1) & \dots & f_p(x^1) \\ f_1(x^2) & f_2^*(x^2) & \dots & f_p(x^2) \\ \dots & \dots & \dots & \dots \\ f_1(x^p) & f_2(x^p) & \dots & f_p^*(x^p) \end{bmatrix}$$

**Step-3** For each objective  $f_k(x)$ ,the lower bound  $L_k^T$  and upper bound  $U_k^T$  as

$$U_k^T = \max \{f_k(x^{r*})\} \quad (1.512)$$

and  $L_k^T = \min \{f_k(x^{r*})\}$  (1.513)

where  $r = 1, 2, \dots, k$  for truth membership function of objectives.

**Step-4** We represents upper and lower bounds for indeterminacy and falsity membership of objectives as follows

Model- I,II-AL,AN

$U_k^F = U_k^T$  and

$$L_k^F = L_k^T + t(U_k^T - L_k^T) \quad (1.514)$$

$U_k^I = U_k^T$  and

$$L_k^I = L_k^T + s(U_k^T - L_k^T) \quad (1.515)$$

Here  $t$  and  $s$  are predetermined real number in  $(0,1)$

Model-I,II-BL,BN

$U_k^F = U_k^T = U_k^I$  and

$$L_k^F = L_k^T + t(U_k^T - L_k^T)$$



$$L_k^I = L_k^T + s(U_k^T - L_k^T)$$

Here  $t$  and  $s$  are predetermined real number in  $(0,1)$

**Step-5** Define Truth membership, Indeterminacy membership, Falsity membership functions as follows

$$T_k(f_k(x)) = \begin{cases} 1 & \text{if } f_k(x) \leq L_k^T \\ \frac{U_k^T - f_k(x)}{U_k^T - L_k^T} & \text{if } L_k^T \leq f_k(x) \leq U_k^T \\ 0 & \text{if } f_k(x) \geq U_k^T \end{cases} \quad (1.516)$$

For Model-I,II-AL

$$I_k(f_k(x)) = \begin{cases} 1 & \text{if } f_k(x) \leq L_k^I \\ \frac{U_k^I - f_k(x)}{U_k^I - L_k^I} & \text{if } L_k^I \leq f_k(x) \leq U_k^I \\ 0 & \text{if } f_k(x) \geq U_k^I \end{cases} \quad (1.517)$$

For Model-I,II-BL

$$I_k(f_k(x)) = \begin{cases} 1 & \text{if } f_k(x) \geq U_k^I \\ \frac{f_k(x) - L_k^I}{U_k^I - L_k^I} & \text{if } L_k^I \leq f_k(x) \leq U_k^I \\ 0 & \text{if } f_k(x) \leq L_k^I \end{cases} \quad (1.518)$$

$$F_k(f_k(x)) = \begin{cases} 1 & \text{if } f_k(x) \leq L_k^F \\ \frac{f_k(x) - L_k^F}{U_k^F - L_k^F} & \text{if } L_k^F \leq f_k(x) \leq U_k^F \\ 0 & \text{if } f_k(x) \geq U_k^F \end{cases} \quad (1.519)$$

**Step-6** Now neutrosophic optimization method for MONLP problem gives an equivalent nonlinear-programing problem as

**Model-I-A,B**

**(P1. 49)**

$$\text{Max } (\alpha - \beta + \gamma) \quad (1.520)$$

Such that

$$T_k(f_k(x)) \geq \alpha; \quad (1.521)$$

$$I_k(f_k(x)) \geq \gamma; \quad (1.522)$$

$$F_k(f_k(x)) \leq \beta; \quad (1.523)$$

$$\alpha + \beta + \gamma \leq 3; \quad (1.524)$$

$$\alpha \geq \beta; \quad (1.525)$$

$$\alpha \geq \gamma; \quad (1.526)$$

$$\alpha, \beta, \gamma \in [0, 1]; \quad (1.527)$$

$$g_j(x) \leq b_j; x \geq 0 \quad (1.528)$$

$$k = 1, 2, \dots, p; j = 1, 2, \dots, q \quad (1.529)$$

In Model-I-A and Model-I-B we will consider the indeterminacy membership function as decreasing sense and increasing sense and increasing sense respectively.

Also as a decision maker needs to minimize hesitancy function in decision making problem, the above problem can be formulated as

### **Model-II-A,B**

**(P1. 50)**

$$\text{Max } (\alpha - \beta - \gamma) \quad (1.530)$$

Such that

$$T_k(f_k(x)) \geq \alpha; \quad (1.531)$$

$$I_k(f_k(x)) \leq \gamma; \quad (1.532)$$

$$F_k(f_k(x)) \leq \beta; \quad (1.533)$$

$$\alpha + \beta + \gamma \leq 3; \quad (1.534)$$

$$\alpha \geq \beta; \quad (1.535)$$

$$\alpha \geq \gamma; \quad (1.536)$$

$$\alpha, \beta, \gamma \in [0, 1]; \quad (1.537)$$

$$g_j(x) \leq b_j; x \geq 0 \quad (1.356)$$

$$k = 1, 2, \dots, p; j = 1, 2, \dots, q$$

Which is reduced to equivalent non-linear programming problem as

**Model-I-AL****(P1. 51)**

$$\text{Max } (\alpha - \beta + \gamma) \quad (1.538)$$

Such that

$$f_k(x) + (U_k^T - L_k^T) \cdot \alpha \leq U_k^T \quad (1.539)$$

$$f_k(x) + (U_k^I - L_k^I) \cdot \gamma \leq U_k^I \quad (1.540)$$

$$f_k(x) - (U_k^F - L_k^F) \cdot \beta \leq L_k^F \quad (1.541)$$

$$\alpha + \beta + \gamma \leq 3; \quad (1.542)$$

$$\alpha \geq \beta; \quad (1.543)$$

$$\alpha \geq \gamma; \quad (1.544)$$

$$\alpha, \beta, \gamma \in [0, 1]; \quad (1.545)$$

$$g_j(x) \leq b_j; x \geq 0 \quad (1.546)$$

$$k = 1, 2, \dots, p; j = 1, 2, \dots, q$$

**Model-I-BL****(P1. 52)**

$$\text{Max } (\alpha - \beta + \gamma) \quad (1.547)$$

Such that

$$f_k(x) + (U_k^T - L_k^T) \cdot \alpha \leq U_k^T \quad (1.548)$$

$$f_k(x) - (U_k^I - L_k^I) \cdot \gamma \geq L_k^I \quad (1.549)$$

$$f_k(x) - (U_k^F - L_k^F) \cdot \beta \leq L_k^F \quad (1.550)$$

$$\alpha + \beta + \gamma \leq 3; \quad (1.551)$$

$$\alpha \geq \beta; \quad (1.552)$$

$$\alpha \geq \gamma; \quad (1.553)$$

$$\alpha, \beta, \gamma \in [0, 1]; \quad (1.554)$$

$$g_j(x) \leq b_j; x \geq 0 \quad (1.555)$$

$$k = 1, 2, \dots, p; j = 1, 2, \dots, q$$

And

**Model-II-AL**

**(P1. 53)**

$$\text{Max } (\alpha - \beta - \gamma) \quad (1.556)$$

Subject to

$$f_k(x) + (U_k^T - L_k^T) \cdot \alpha \leq U_k^T \quad (1.557)$$

$$f_k(x) + (U_k^I - L_k^I) \cdot \gamma \geq U_k^I \quad (1.558)$$

$$f_k(x) - (U_k^F - L_k^F) \cdot \beta \leq L_k^F \quad (1.559)$$

$$\alpha + \beta + \gamma \leq 3; \quad (1.560)$$

$$\alpha \geq \beta; \quad (1.561)$$

$$\alpha \geq \gamma; \quad (1.562)$$

$$\alpha, \beta, \gamma \in [0, 1]; \quad (1.563)$$

$$g_j(x) \leq b_j; x \geq 0 \quad (1.564)$$

$$k = 1, 2, \dots, p; j = 1, 2, \dots, q$$

**Model-II-B**

**(P1. 54)**

$$\text{Max } (\alpha - \beta - \gamma) \quad (1.565)$$

Subject to

$$f_k(x) + (U_k^T - L_k^T) \cdot \alpha \leq U_k^T \quad (1.566)$$

$$f_k(x) - (U_k^I - L_k^I) \cdot \gamma \leq L_k^I \quad (1.567)$$

$$f_k(x) - (U_k^F - L_k^F) \cdot \beta \leq L_k^F \quad (1.568)$$

$$\alpha + \beta + \gamma \leq 3; \quad (1.569)$$

$$\alpha \geq \beta; \quad (1.570)$$

$$\alpha \geq \gamma; \quad (1.571)$$

$$\alpha, \beta, \gamma \in [0, 1]; \quad (1.572)$$

$$g_j(x) \leq b_j; x \geq 0 \quad (1.573)$$

$$k = 1, 2, \dots, p; j = 1, 2, \dots, q$$

### 1.31 Illustrated Numerical Example

(P1. 55)

$$\text{Min } f_1(x_1, x_2) = x_1^{-1} x_2^{-2}$$

(1.574)

$$\text{Min } f_2(x_1, x_2) = 2x_1^{-2} x_2^{-3}$$

(1.575)

Such that

$$x_1 + x_2 \leq 1$$

(1.576)

$$x_1, x_2 \geq 0$$

(1.577)

Solution : Here  $L_1^T = 6.75$ ,  $U_1^T = 6.94$   $L_2^T = 57.87$ ,  $U_2^T = 60.78$

#### Comparison of optimal solution by IFO and NSO Technique

Optimization Technique	Optimal Decision Variables $x_1^*, x_2^*$	Optimal Objective Functions $f_1^*, f_2^*$	Sum of Optimal Objective Values
Intuitionistic Fuzzy Optimization(IFO)	0.3659009 0.6356811	6.797078 58.79110	65.588178
Proposed Neutrosophic Optimization (NSO) $\varepsilon_1, \xi_1 = 0.019$ $\varepsilon_2, \xi_2 = 0.291$ Model-I-AL	0.3704475 0.6315016	6.769 57.87	64.63
Model-II-AL	0.3659010 0.634099	6.797 58.59	65.38
Model-I-BL	0.3659016 0.6340984	6.797 58.59	65.38
Model-II-BL	0.3659016 0.6340984	6.797 58.59	65.38

Table 1.7 shows that neutrosophic optimization technique gives better result than Intuitionistic Fuzzy Nonlinear Programming Technique.

### 1.32 Application of Neutrosophic Optimization in Riser Design Problem

The function of a riser is to supply additional molten metal to a casting to ensure a shrinkage porosity free casting. Shrinkage porosity occurs because of the increase in density from the liquid to solid state of metals. To be effective a riser must be solidify after casting and contain sufficient metal to feed the casting. Casting solidification time is predicted from Chvorinov's rule. Chvorinov's rule provides guidance on why risers are typically cylindrical. The longest solidification time for a given volume is the one where the shape of the part has the minimum surface area. From a practical standpoint cylinder has least surface area for its volume and easiest to make. Since the riser should solidify a cylinder side riser which consists of a cylinder of height  $H$  and diameter  $D$ . The theoretical basis for riser design is Chvorinov's rule which is  $t = k(V/SA)^2$  where  $t$  = solidification time (minutes/seconds),  $K$  = solidification constant for moulding material (minutes/in<sup>2</sup> or seconds/cm<sup>2</sup>),  $V$  = riser volume (in<sup>3</sup> or cm<sup>3</sup>),  $SA$  = cooling surface area of the riser.

The objective is to design the smallest riser such that  $t_R \geq t_C$  .where  $t_R$  = solidification time of the riser,  $t_C$  = solidification time of the casting,

$$K_R (V_R / SA_R)^2 \geq K_C (V_C / SA_C)^2 \quad (1.578)$$

The riser and casting are assumed to be moulded in the same material so that  $K_R$  and  $K_C$  are equal .So  $(V_R / SA_R) \geq (V_C / SA_C)$  . (1.579)

The casting has a specified volume and surface area, so

$$V_C / SA_C = Y = \text{constant}, \quad (1.580)$$

which is called the casting modulus.

$$V_C / SA_C \geq Y, \quad (1.581)$$

$$V_R = \pi D_R^2 H_R / 4, \quad (1.582)$$

$$SA_R = \pi D_R H_R + 2\pi D_R^2 / 4 \quad (1.583)$$

Therefore

$$\left(\pi D_R^2 / 4\right) \left(\pi D_R H_R + 2\pi D_R^2 / 4\right) = (D_R H_R) / (4H_R + 2D_R) \geq Y \quad (1.584)$$

We take  $V_C = 96$  cubic inch.

$$SA_C = 2(2.8 + 2.6 + 6.8) = 152 \text{ square inch.} \quad (1.585)$$

$$\text{Then, } \frac{49}{19} D_R^{-1} + \frac{24}{19} H_R^{-1} \leq 1 \quad (1.586)$$

Therefore Multi-objective cylindrical riser design problem can be stated as

$$\text{Minimize } V_R(D_R, H_R) = \pi D_R^2 H_R / 4 \quad (1.587)$$

$$\text{Minimize } t_R(D_R, H_R) = (D_R H_R) / (4H_R + 2D_R) \quad (1.588)$$

$$\text{Subject to } \frac{49}{19} D_R^{-1} + \frac{24}{19} H_R^{-1} \leq 1 \quad (1.589)$$

$$D_R, H_R > 0 \quad (1.383)$$

Here pay-off matrix is

$$\begin{matrix} & V_R & T_R \\ \begin{matrix} D_R \\ H_R \end{matrix} & \begin{bmatrix} 42.75642 & 0.631579 \\ 12.510209 & 0.6315786 \end{bmatrix} \end{matrix}$$

**Table 1.7 Values of Optimal Decision Variables and Objective Functions by Neutrosophic Optimization Technique**

Optimal Decision variables	Optimal Objective Functions	Aspiration levels of Truth, Falsity and Indeterminacy Membership Functions
$D_R^* = 3.152158$ $H_R^* = 3.152158$	$V_R^*(D_R^*, H_R^*) = 24.60870$ $t_R^*(D_R^*, H_R^*) = 0.6315787$	$\alpha^* = 0.1428574$ $\beta^* = 0.1428574$ $\gamma^* = 0.00001$

### 1.33 Neutrosophic Optimization(NSO) Technique to Solve Minimization Type Multi-Objective Non-linear Programming Problem(MONLP)

A nonlinear multi-objective optimization problem is of the form

**(P1. 56)**

$$\text{Minimize } \{f_1(x), f_2(x), \dots, f_p(x)\} \quad (1.590)$$

$$g_j(x) \leq b_j \quad j = 1, 2, \dots, q \quad (1.591)$$

Now the decision set  $\tilde{D}^n$ , a conjunction of Neutrosophic objectives and constraints is defined

$$\tilde{D}^n = \left( \bigcap_{k=1}^p \tilde{G}_k^n \right) \cap \left( \bigcap_{j=1}^q \tilde{C}_j^n \right) = \{(x, T_{\tilde{D}^n}(x)) I_{\tilde{D}^n}(x), F_{\tilde{D}^n}(x)\} \quad (1.592)$$

Here

$$T_{\tilde{D}^n}(x) = \min \left\{ \begin{array}{l} T_{\tilde{G}_1^n}(x), T_{\tilde{G}_2^n}(x), T_{\tilde{G}_3^n}(x), \dots, T_{\tilde{G}_p^n}(x); \\ T_{\tilde{C}_1^n}(x), T_{\tilde{C}_2^n}(x), T_{\tilde{C}_3^n}(x), \dots, T_{\tilde{C}_q^n}(x) \end{array} \right\} \text{ for all } x \in X \quad (1.593)$$

$$I_{\tilde{D}^n}(x) = \min \left\{ \begin{array}{l} I_{\tilde{G}_1^n}(x), I_{\tilde{G}_2^n}(x), I_{\tilde{G}_3^n}(x), \dots, I_{\tilde{G}_p^n}(x); \\ I_{\tilde{C}_1^n}(x), I_{\tilde{C}_2^n}(x), I_{\tilde{C}_3^n}(x), \dots, I_{\tilde{C}_q^n}(x) \end{array} \right\} \text{ for all } x \in X \quad (1.594)$$

$$F_{\tilde{D}^n}(x) = \min \left\{ \begin{array}{l} F_{\tilde{G}_1^n}(x), F_{\tilde{G}_2^n}(x), F_{\tilde{G}_3^n}(x), \dots, F_{\tilde{G}_p^n}(x); \\ F_{\tilde{C}_1^n}(x), F_{\tilde{C}_2^n}(x), F_{\tilde{C}_3^n}(x), \dots, F_{\tilde{C}_q^n}(x) \end{array} \right\} \text{ for all } x \in X \quad (1.595)$$

Where  $T_{\tilde{D}^n}(x), I_{\tilde{D}^n}(x), F_{\tilde{D}^n}(x)$  are truth-membership function, indeterminacy membership function, falsity membership function of neutrosophic decision set respectively .Now using the definition of Smarandache's intersection of neutrosophic sets and criteria of decision making (P1.56) is transformed to the non-linear programming problem as

#### Model-I-AN,BN

(P1. 57)

$$\text{Max } \alpha \quad (1.596)$$

$$\text{Max } \gamma \quad (1.597)$$

$$\text{Min } \beta \quad (1.598)$$

such that

$$T_{\tilde{G}_k^n}(x) \geq \alpha; \quad (1.599)$$

$$T_{\tilde{C}_j^n}(x) \geq \alpha; \quad (1.600)$$

$$I_{\tilde{G}_k^n}(x) \geq \gamma; \quad (1.601)$$

$$I_{\tilde{C}_j^n}(x) \geq \gamma; \quad (1.602)$$

$$F_{\tilde{G}_k^n}(x) \leq \beta; \quad (1.603)$$

$$F_{\tilde{C}_j^n}(x) \leq \beta; \quad (1.604)$$

$$\alpha + \beta + \gamma \leq 3; \quad (1.605)$$

$$\alpha \geq \beta; \alpha \geq \gamma; \quad (1.606)$$

$$\alpha, \beta, \gamma \in [0,1] \quad (1.607)$$

Here Model-I-AN and Model-I-BN stands for the algorithm with decreasing indeterminacy nonlinear membership function and increasing indeterminacy nonlinear membership function respectively.



But as the decision makers needs to minimize indeterminacy membership function in real world problem the above problem can be formulated as

Model-II-AN,BN

**(P1. 58)**

$$\text{Max } \alpha \tag{1.608}$$

$$\text{Min } \gamma \tag{1.609}$$

$$\text{Min } \beta \tag{1.610}$$

*such that*

$$T_{\tilde{C}_k^n}(x) \geq \alpha; \tag{1.611}$$

$$T_{\tilde{C}_j^n}(x) \geq \alpha; \tag{1.612}$$

$$I_{\tilde{G}_k^n}(x) \leq \gamma; \tag{1.613}$$

$$I_{\tilde{C}_j^n}(x) \leq \gamma; \tag{1.614}$$

$$F_{\tilde{G}_k^n}(x) \leq \beta; \tag{1.615}$$

$$F_{\tilde{C}_j^n}(x) \leq \beta; \tag{1.616}$$

$$\alpha + \beta + \gamma \leq 3; \tag{1.617}$$

$$\alpha \geq \beta; \alpha \geq \gamma; \tag{1.618}$$

$$\alpha, \beta, \gamma \in [0,1]$$

Here Model-II-AN and Model-II-BN stand for same as Model-I

Now this NLP problem (P1.57) and (P1.58) can be easily solved by an appropriate mathematical programming to give solution of MONLP problem (P1.56) by NSO approach.

### **Computational Algorithm**

**Step-1:** Solve the MONLP problem (P1.56) as a single objective non-linear problem p times for each problem by taking one of the objectives at a time and ignoring the others. These solution are known as ideal solutions. Let  $x^k$  be the respective optimal solution for the  $k^{th}$  different objective and evaluate each objective values for all these  $k^{th}$  optimal solution.

**Step-2:** From the result of step-1, determine the corresponding values for every objective for each derived solution; pay-off matrix can be formulated as follows

$$\begin{bmatrix} f_1^*(x^1) & f_2(x^1) & \dots & f_p(x^1) \\ f_1(x^2) & f_2^*(x^2) & \dots & f_p(x^2) \\ \dots & \dots & \dots & \dots \\ f_1(x^p) & f_2(x^p) & \dots & f_p^*(x^p) \end{bmatrix}$$

**Step-3:** For each objective  $f_k(x)$  find lower bound  $L_k^T$  and the upper bound  $U_k^T$

$$U_k^T = \max \{f_k(x^{r*})\} \quad (1.619)$$

$$L_k^T = \min \{f_k(x^{r*})\} \text{ where } r = 1, 2, \dots, k \quad (1.620)$$

For truth membership of objectives.

**Step-4:** We represent upper and lower bounds for indeterminacy and falsity membership of objectives as follows :

for  $k = 1, 2, \dots, p$

Model-I,II-AL,AN

$$U_k^F = U_k^T \quad (1.621)$$

$$L_k^F = L_k^T + t(U_k^T - L_k^T); \quad (1.622)$$

$$L_k^I = L_k^T \quad (1.623)$$

$$U_k^I = L_k^T + s(U_k^T - L_k^T) \quad (1.624)$$

Here  $t, s$  are predetermined real numbers in  $(0,1)$

and for Model-I,II-BL,BN

$$U_k^F = U_k^T = U_k^I$$

$$L_k^F = L_k^T + t(U_k^T - L_k^T);$$

$$L_k^I = L_k^T + s(U_k^T - L_k^T)$$

Here  $t, s$  are predetermined real numbers in  $(0,1)$

**Step-5:** Define nonlinear truth membership, indeterminacy membership and falsity membership functions as follows

for  $k = 1, 2, \dots, p$

$$T_{f_k(x)}(f_k(x)) = \begin{cases} 1 & \text{if } f_k(x) \leq L_{f_k(x)}^T \\ 1 - \exp\left\{-\psi\left(\frac{U_{f_k(x)}^T - f_k(x)}{U_{f_k(x)}^T - L_{f_k(x)}^T}\right)\right\} & \text{if } L_{f_k(x)}^T \leq f_k(x) \leq U_{f_k(x)}^T \\ 0 & \text{if } f_k(x) \geq U_{f_k(x)}^T \end{cases} \quad (1.625)$$

For Model-I,II-AN

$$I_{f_k(x)}(f_k(x)) = \begin{cases} 1 & \text{if } f_k(x) \leq L_{f_k(x)}^I \\ \exp\left\{\frac{U_{f_k(x)}^I - f_k(x)}{U_{f_k(x)}^I - L_{f_k(x)}^I}\right\} & \text{if } L_{f_k(x)}^I \leq f_k(x) \leq U_{f_k(x)}^I \\ 0 & \text{if } f_k(x) \geq U_{f_k(x)}^I \end{cases} \quad (1.626)$$

For Model-I,II-BN

$$I_{f_k(x)}(f_k(x)) = \begin{cases} 1 & \text{if } f_k(x) \geq U_{f_k(x)}^I \\ \exp\left\{\frac{f_k(x) - L_{f_k(x)}^I}{U_{f_k(x)}^I - L_{f_k(x)}^I}\right\} & \text{if } L_{f_k(x)}^I \leq f_k(x) \leq U_{f_k(x)}^I \\ 0 & \text{if } f_k(x) \leq L_{f_k(x)}^I \end{cases} \quad (1.627)$$

$$F_{f(x)}(f(x)) = \begin{cases} 0 & \text{if } f(x) \leq L_{f(x)}^F \\ \frac{1}{2} + \frac{1}{2} \tanh\left\{\left(f(x) - \frac{U_{f(x)}^F + L_{f(x)}^F}{2}\right)\tau_{f(x)}\right\} & \text{if } L_{f(x)}^F \leq f(x) \leq U_{f(x)}^F \\ 1 & \text{if } f(x) \geq U_{f(x)}^F \end{cases} \quad (1.628)$$

**Step-6:** Now neutrosophic optimization method for MONLP problem gives a equivalent nonlinear programming problem as:

**Model-I-AN,BN**

**(P1. 59)**

$$\text{Maximize } (\alpha - \beta + \gamma) \quad (1.629)$$

such that

$$T_k(f_k(x)) \geq \alpha; \quad (1.630)$$

$$I_k(f_k(x)) \geq \gamma; \quad (1.631)$$

$$F_k(f_k(x)) \leq \beta; \quad (1.632)$$

$$\alpha + \beta + \gamma \leq 3; \quad (1.633)$$

$$\alpha \geq \beta; \quad (1.634)$$

$$\alpha \geq \gamma; \quad (1.635)$$

$$\alpha, \beta, \gamma \in [0, 1]; \quad (1.636)$$

$$g_j(x) \leq b_j \quad (1.637)$$

$$x \geq 0, \quad (1.638)$$

$$k = 1, 2, \dots, p; \quad j = 1, 2, \dots, q \quad (1.639)$$

### **Model-II-AN,BN**

#### **(P1. 60)**

$$\text{Maximize } (\alpha - \beta + \gamma) \quad (1.640)$$

*such that*

$$T_k(f_k(x)) \geq \alpha; \quad (1.641)$$

$$I_k(f_k(x)) \leq \gamma; \quad (1.642)$$

$$F_k(f_k(x)) \leq \beta; \quad (1.643)$$

$$\alpha + \beta + \gamma \leq 3; \quad (1.644)$$

$$\alpha \geq \beta; \quad (1.645)$$

$$\alpha \geq \gamma; \quad (1.646)$$

$$\alpha, \beta, \gamma \in [0, 1]; \quad (1.647)$$

$$g_j(x) \leq b_j \quad (1.648)$$

$$x \geq 0, \quad (1.649)$$

$$k = 1, 2, \dots, p; \quad j = 1, 2, \dots, q$$

Where Model-I,II-AN and Model-I,II-BN stands for the optimization algorithm with decreasing indeterminacy nonlinear membership function and increasing indeterminacy nonlinear membership function respectively.

which is reduced to equivalent nonlinear programming problem as

### **Model-I-AN**

#### **(P1. 61)**

$$\text{Maximize } (\theta - \eta + \kappa) \quad (1.650)$$

*such that*

$$f_k(x) + \frac{\theta(U_k^T - L_k^T)}{4} \leq U_k^T;$$

(1.651)

$$f_k(x) + \frac{\eta}{\tau_{f_k}} \leq \frac{U_k^T + L_k^T + \varepsilon_{f_k}}{2}; \quad (1.652)$$

$$f_k(x) + \kappa \xi_{f_k} \leq L_k^T + \xi_{f_k}; \quad \text{for } k = 1, 2, \dots, p \quad (1.653)$$

$$\text{where } \eta = \tanh^{-1}(2\beta - 1), \quad (1.654)$$

$$\theta = -\log(1 - \alpha) \quad (1.655)$$

$$\kappa = \log \gamma \quad (1.656)$$

$$\psi = 4, \quad (1.657)$$

$$\tau_{f_k} = \frac{6}{U_k^F - L_k^F} \quad (1.658)$$

$$\theta + \kappa + \eta \leq 3; \quad (1.659)$$

$$\theta \geq \kappa; \quad (1.660)$$

$$\theta \geq \eta; \quad (1.661)$$

$$\theta, \kappa, \eta \in [0, 1]; \quad (1.662)$$

$$g_j(x) \leq b_j; \quad (1.663)$$

$$x \geq 0, \quad (1.664)$$

and

### Model-I-BN

(P1. 62)

$$\text{Maximize } (\theta - \eta + \kappa) \quad (1.665)$$

such that

$$f_k(x) + \frac{\theta(U_k^T - L_k^T)}{4} \leq U_k^T;$$

(1.666)

$$f_k(x) + \frac{\eta}{\tau_{f_k}} \leq \frac{U_k^T + L_k^T + \varepsilon_{f_k}}{2}; \quad (1.667)$$

$$f_k(x) - \kappa(U_k^T - L_k^T - \xi_{f_k}) \geq L_k^T + \xi_{f_k}; \quad \text{for } k = 1, 2, \dots, p \quad (1.668)$$

$$\text{where } \eta = \tanh^{-1}(2\beta - 1), \quad (1.669)$$

$$\theta = -\log(1 - \alpha) \quad (1.670)$$

$$\kappa = \log \gamma \quad (1.671)$$

$$\psi = 4, \quad (1.672)$$

$$\tau_{f_k} = \frac{6}{U_k^F - L_k^F} \quad (1.673)$$

$$\theta + \kappa + \eta \leq 3; \quad (1.674)$$

$$\theta \geq \kappa; \quad (1.675)$$

$$\theta \geq \eta; \quad (1.676)$$

$$\theta, \kappa, \eta \in [0, 1]; \quad (1.677)$$

$$g_j(x) \leq b_j; \quad (1.678)$$

$$x \geq 0,$$

This crisp nonlinear programming problem can be solved by appropriate mathematical algorithm. Again according to decision makers choice the above problem also can be formulated as

#### Model-II-AN

##### (P1. 63)

$$\text{Maximize } (\theta - \eta - \kappa) \quad (1.679)$$

such that

$$f_k(x) + \frac{\theta(U_k^T - L_k^T)}{4} \leq U_k^T; \quad (1.680)$$

(1.680)

$$f_k(x) + \frac{\eta}{\tau_{f_k}} \leq \frac{U_k^T + L_k^T + \varepsilon_{f_k}}{2}; \quad (1.681)$$

$$f_k(x) + \kappa \xi_{f_k} \geq L_k^T + \xi_{f_k}; \quad \text{for } k = 1, 2, \dots, p \quad (1.682)$$

$$\text{where } \eta = \tanh^{-1}(2\beta - 1), \quad (1.683)$$

$$\theta = -\log(1 - \alpha) \quad (1.684)$$

$$\kappa = \log \gamma \quad (1.685)$$

$$\psi = 4, \quad (1.686)$$

$$\tau_{f_k} = \frac{6}{U_k^F - L_k^F} \quad (1.687)$$

$$\theta + \kappa + \eta \leq 3; \quad (1.688)$$

$$\theta \geq \kappa; \quad (1.689)$$

$$\theta \geq \eta; \quad (1.690)$$

$$\theta, \kappa, \eta \in [0, 1]; \quad (1.691)$$

$$g_j(x) \leq b_j; \quad (1.692)$$

$$x \geq 0, \quad (1.693)$$

And

### Model-II-B

(P1. 64)

$$\text{Maximize } (\theta - \eta - \kappa) \quad (1.694)$$

such that

$$f_k(x) + \frac{\theta(U_k^T - L_k^T)}{4} \leq U_k^T;$$

(1.695)

$$f_k(x) + \frac{\eta}{\tau_{f_k}} \leq \frac{U_k^T + L_k^T + \varepsilon_{f_k}}{2}; \quad (1.696)$$

$$f_k(x) - \kappa(U_k^T - L_k^T - \xi_{f_k}) \leq L_k^T + \xi_{f_k}; \text{ for } k = 1, 2, \dots, p \quad (1.697)$$

$$\text{where } \eta = \tanh^{-1}(2\beta - 1), \quad (1.698)$$

$$\theta = -\log(1 - \alpha) \quad (1.699)$$

$$\kappa = \log \gamma \quad (1.700)$$

$$\psi = 4, \quad (1.701)$$

$$\tau_{f_k} = \frac{6}{U_k^F - L_k^F} \quad (1.702)$$

$$\theta + \kappa + \eta \leq 3; \quad (1.703)$$

$$\theta \geq \kappa; \quad (1.704)$$

$$\theta \geq \eta; \quad (1.705)$$

$$\theta, \kappa, \eta \in [0, 1]; \quad (1.706)$$

$$g_j(x) \leq b_j; \tag{1.707}$$

$$x \geq 0,$$

All the above crisp problems can be solved by appropriate optimization solver(LINGO).

### 1.34 Neutrosophic Goal Programming(NGP)

Goal programming can be written as

**(P1. 65)**

Find

$$x = (x_1, x_2, \dots, x_n)^T \tag{1.708}$$

to achieve:

$$z_i = t_i \quad i = 1, 2, \dots, k \tag{1.709}$$

subject to  $x \in X$  where  $t_i$  are scalars and represent the target achievement levels of the objective functions that the decision maker wishes to attain provided,  $X$  is feasible set of constraints.

The nonlinear goal programming problem can be written as

**(P1. 66)**

$$\text{Find } x = (x_1, x_2, \dots, x_n)^T \tag{1.710}$$

so as to

$$\text{Minimize } z_i \text{ with target value } t_i, \text{ acceptance tolerance } a_i, \text{ indeterminacy tolerance } d_i, \text{ rejection tolerance } c_i \tag{1.711}$$

$$x \in X \tag{1.712}$$

$$g_j(x) \leq b_j, \quad j = 1, 2, \dots, m \tag{1.713}$$

$$x_i \geq 0, \quad i = 1, 2, \dots, n \tag{1.714}$$

with truth-membership, indeterminacy-membership and falsity-membership functions

$$T_i^1(z_i) = \begin{cases} 1 & \text{if } z_i \leq t_i \\ \left( \frac{t_i + a_i - z_i}{a_i} \right) & \text{if } t_i \leq z_i \leq t_i + a_i \\ 0 & \text{if } z_i \geq t_i + a_i \end{cases} \tag{1.715}$$



$$I_i^1(z_i) = \begin{cases} 0 & \text{if } z_i \leq t_i \\ \left(\frac{z_i - t_i}{d_i}\right) & \text{if } t_i \leq z_i \leq t_i + a_i \\ \left(\frac{t_i + a_i - z_i}{a_i - d_i}\right) & \text{if } t_i + d_i \leq z_i \leq t_i + a_i \\ 0 & \text{if } z_i \geq t_i + a_i \end{cases} \quad (1.716)$$

$$F_i^1(z_i) = \begin{cases} 0 & \text{if } z_i \leq t_i \\ \left(\frac{z_i - t_i}{c_i}\right) & \text{if } t_i \leq z_i \leq t_i + c_i \\ 1 & \text{if } z_i \geq t_i + c_i \end{cases} \quad (1.717)$$

To maximize the degree of acceptance and indeterminacy and to minimize the degree of rejection of objectives and constraints of nonlinear goal programming (NGP), let us consider the following formulation,

**(P1. 67)**

$$\text{Maximize } T_{z_i}(z_i), \quad i = 1, 2, \dots, k \quad (1.718)$$

$$\text{Maximize } I_{z_i}(z_i), \quad i = 1, 2, \dots, k \quad (1.719)$$

$$\text{Minimize } F_{z_i}(z_i), \quad i = 1, 2, \dots, k \quad (1.720)$$

subject to

$$0 \leq T_{z_i}(z_i) + I_{z_i}(z_i) + F_{z_i}(z_i) \leq 3, \quad i = 1, 2, \dots, k \quad (1.721)$$

$$T_{z_i}(z_i) \geq 0, I_{z_i}(z_i) \geq 0, F_{z_i}(z_i) > 0 \quad i = 1, 2, \dots, k \quad (1.722)$$

$$T_{z_i}(z_i) \geq I_{z_i}(z_i), \quad i = 1, 2, \dots, k \quad (1.723)$$

$$T_{z_i}(z_i) \geq F_{z_i}(z_i), \quad i = 1, 2, \dots, k \quad (1.724)$$

$$g_j(x) \leq b_j, \quad j = 1, 2, \dots, m \quad (1.725)$$

$$x_i \geq 0, \quad i = 1, 2, \dots, n \quad (1.726)$$

where  $T_{z_i}(z_i)$ ,  $I_{z_i}(z_i)$  and  $F_{z_i}(z_i)$  are truth membership function indeterminacy membership function, falsity membership function of neutrosophic decision set respectively.

Now the NGP in model (P1.67) can be represented by crisp programming model using truth membership, indeterminacy membership, and falsity membership functions as

**(P1. 68)**

$$\text{Maximize } \alpha, \text{Maximize } \gamma, \text{Minimize } \beta \quad (1.727)$$

$$T_{z_i}(z_i) \geq \alpha, i = 1, 2, \dots, k \quad (1.728)$$

$$I_{z_i}(z_i) \geq \gamma, i = 1, 2, \dots, k \quad (1.729)$$

$$F_{z_i}(z_i) \leq \beta, i = 1, 2, \dots, k \quad (1.730)$$

$$z_i \leq t_i, i = 1, 2, \dots, k \quad (1.731)$$

$$0 \leq \alpha + \beta + \gamma \leq 3; \quad (1.732)$$

$$\alpha, \gamma \geq 0, \beta \leq 1; \quad (1.733)$$

$$g_j(x) \leq b_j, j = 1, 2, \dots, m \quad (1.734)$$

$$x_i \geq 0, i = 1, 2, \dots, n \quad (1.735)$$

### 1.35 Theorem on Generalized Goal Programming

For a generalized neutrosophic goal programming problem (P1.65)

The sum of truth, indeterminacy and falsity membership function will lie between 0 and

$$w_1 + w_2 + w_3$$

Proof:

Let the truth, indeterminacy and falsity membership functions be defined as membership functions

$$T_i^{w_1}(z_i) = \begin{cases} w_1 & \text{if } z_i \leq t_i \\ w_1 \left( \frac{t_i + a_i - z_i}{a_i} \right) & \text{if } t_i \leq z_i \leq t_i + a_i \\ 0 & \text{if } z_i \geq t_i + a_i \end{cases} \quad (1.736)$$

$$I_i^{w_2}(z_i) = \begin{cases} 0 & \text{if } z_i \leq t_i \\ w_2 \left( \frac{z_i - t_i}{d_i} \right) & \text{if } t_i \leq z_i \leq t_i + a_i \\ w_2 \left( \frac{t_i + a_i - z_i}{a_i - d_i} \right) & \text{if } t_i + d_i \leq z_i \leq t_i + a_i \\ 0 & \text{if } z_i \geq t_i + a_i \end{cases} \quad (1.737)$$

$$F_i^{w_3}(z_i) = \begin{cases} 0 & \text{if } z_i \leq t_i \\ w_3 \left( \frac{z_i - t_i}{c_i} \right) & \text{if } t_i \leq z_i \leq t_i + c_i \\ w_3 & \text{if } z_i \geq t_i + c_i \end{cases} \quad (1.738)$$

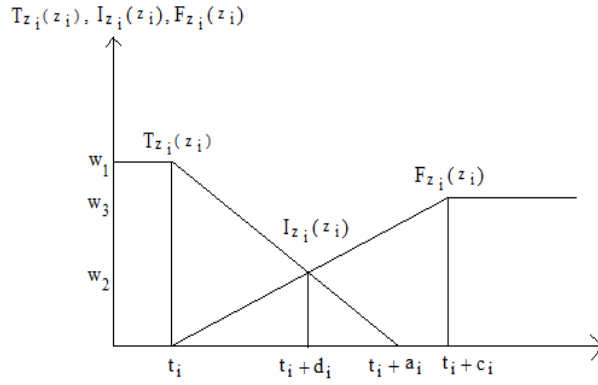

**Fig.-1.2 Truth Membership, Indeterminacy Membership and Falsity Membership Function of  $z_i$**

From Fig. -1.2 and definition of generalized single valued neutrosophic set it is clear that

$$0 \leq T_{z_i}(z_i) \leq w_1, 0 \leq I_{z_i}(z_i) \leq w_2 \text{ and } 0 \leq F_{z_i}(z_i) \leq w_1 \quad (1.739)$$

When  $(z_i) \leq t_i$

$$T_{z_i}(z_i) = w_1 \text{ and } I_{z_i}(z_i) = 0 \text{ and } F_{z_i}(z_i) = 0 \quad (1.740)$$

$$\text{Therefore } T_{z_i}(z_i) + I_{z_i}(z_i) + F_{z_i}(z_i) = w_1 \leq w_1 + w_2 + w_3 \quad (1.741)$$

$$\text{and } w_1 \geq 0 \text{ implies that } T_{z_i}(z_i) + I_{z_i}(z_i) + F_{z_i}(z_i) \geq 0 \quad (1.742)$$

when  $z_i \in (t_i, t_i + a_i)$  from Fig.-1.2 we see that  $T_{z_i}(z_i)$  and  $F_{z_i}(z_i)$  intersects each other and the point whose coordinate is  $(t_i + d_i, d_i c_i)$ .

$$\text{where } d_i = \frac{w_1}{\frac{w_1}{a_i} + \frac{w_2}{c_i}} \quad (1.743)$$

Now in the interval  $z_i \in (t_i, t_i + d_i)$  we see that

$$T_{z_i}(z_i) + I_{z_i}(z_i) + F_{z_i}(z_i) = w_2 \left( \frac{z_i - t_i}{d_i} \right) \leq w_2 \leq w_1 + w_2 + w_3 \quad (1.744)$$

$$\text{Again in the interval } z_i \in (t_i + d_i, t_i + a_i) \quad (1.745)$$

$$\text{we see that } T_{z_i}(z_i) + I_{z_i}(z_i) + F_{z_i}(z_i) = w_2 \left( \frac{t_i + a_i - z_i}{a_i - d_i} \right) \leq w_2 \leq w_1 + w_2 + w_3. \quad (1.746)$$

$$\text{Also for } t_i \leq z_i \leq t_i + a_i \quad (1.747)$$

$$\text{when } z_i \geq t_i, T_{z_i}(z_i) + I_{z_i}(z_i) + F_{z_i}(z_i) > w_2 \geq 0 \quad (1.748)$$

$$\text{and } T_{z_i}(z_i) + I_{z_i}(z_i) + F_{z_i}(z_i) > w_1 \geq 0 \quad (1.749)$$

and when  $z_i \leq t_i + a_i$ ,  $T_{z_i}(z_i) + I_{z_i}(z_i) + F_{z_i}(z_i) \leq w_1 \frac{a_i}{c_i} < w_1 \leq w_1 + w_2$  (as  $\frac{a_i}{c_i} \leq 1$ ).

$$\text{In the interval } z_i \in (t_i + a_i, t_i + c_i] \quad (1.750)$$

$$\text{when } z_i > t_i + a_i, T_{z_i}(z_i) + I_{z_i}(z_i) + F_{z_i}(z_i) > w_2 \frac{a_i}{c_i} > w_2 \geq 0 \text{ (as } \frac{a_i}{c_i} \leq 1) \quad (1.751)$$

$$\text{and when } z_i \leq t_i + c_i, T_{z_i}(z_i) + I_{z_i}(z_i) + F_{z_i}(z_i) \leq w_1 \leq w_1 + w_2 + w_3 \quad (1.752)$$

$$\text{for } z_i > t_i + c_i, T_{z_i}(z_i) + I_{z_i}(z_i) + F_{z_i}(z_i) = w_3 \leq w_1 + w_2 + w_3 \quad (1.753)$$

$$\text{and as } w_2 \geq 0, T_{z_i}(z_i) + I_{z_i}(z_i) + F_{z_i}(z_i) \geq 0 \quad (1.754)$$

Therefore combining all the cases we get

$$0 \leq T_{z_i}(z_i) + I_{z_i}(z_i) + F_{z_i}(z_i) \leq w_1 + w_2 + w_3 \quad (1.755)$$

Hence the proof.

### 1.36 Generalized Neutrosophic Goal Programming(GNGP)

The Generalized Neutrosophic Goal Programming(GNGP) can be formulated as

**(P1. 69)**

$$\text{Maximize } T_{z_i}(z_i), i = 1, 2, \dots, k \quad (1.756)$$

$$\text{Maximize } I_{z_i}(z_i), i = 1, 2, \dots, k \quad (1.757)$$

$$\text{Minimize } F_{z_i}(z_i), i = 1, 2, \dots, k \quad (1.758)$$

subject to

$$0 \leq T_{z_i}(z_i) + I_{z_i}(z_i) + F_{z_i}(z_i) \leq w_1 + w_2 + w_3, i = 1, 2, \dots, k \quad (1.759)$$

$$T_{z_i}(z_i) \geq 0, I_{z_i}(z_i) \geq 0, F_{z_i}(z_i) > 0 i = 1, 2, \dots, k \quad (1.760)$$

$$T_{z_i}(z_i) \geq I_{z_i}(z_i), i = 1, 2, \dots, k \quad (1.761)$$

$$T_{z_i}(z_i) \geq F_{z_i}(z_i), i = 1, 2, \dots, k \quad (1.762)$$

$$0 \leq w_1 + w_2 + w_3 \leq 3 \quad (1.763)$$

$$w_1, w_2, w_3 \in [0, 1] \quad (1.764)$$

$$g_j(x) \leq b_j, j = 1, 2, \dots, m$$

(1.765)

$$x_i \geq 0, i = 1, 2, \dots, n \quad (1.766)$$

Equivalently

$$\text{Maximize } \alpha, \text{Maximize } \gamma, \text{Minimize } \beta \quad (1.767)$$

$$T_{z_i}(z_i) \geq \alpha, i = 1, 2, \dots, k \quad (1.768)$$

$$I_{z_i}(z_i) \geq \gamma, i = 1, 2, \dots, k \quad (1.769)$$

$$F_{z_i}(z_i) \leq \beta, i = 1, 2, \dots, k \quad (1.770)$$

$$z_i \leq t_i, i = 1, 2, \dots, k \quad (1.771)$$

$$0 \leq \alpha + \beta + \gamma \leq w_1 + w_2 + w_3; \quad (1.772)$$

$$\alpha \in [0, w_1], \gamma \in [0, w_2], \beta \in [0, w_3]; \quad (1.773)$$

$$w_1 \in [0, 1], w_2 \in [0, 1], w_3 \in [0, 1]; \quad (1.774)$$

$$0 \leq w_1 + w_2 + w_3 \leq 3; \quad (1.775)$$

$$g_j(x) \leq b_j, j = 1, 2, \dots, m \quad (1.776)$$

$$x_j \geq 0, j = 1, 2, \dots, n \quad (1.777)$$

Equivalently

**(P1. 70)**

$$\text{Maximize } \alpha, \text{Maximize } \gamma, \text{Minimize } \beta \quad (1.778)$$

$$z_i \leq t_i + a_i \left( 1 - \frac{\alpha}{w_1} \right), i = 1, 2, \dots, k \quad (1.779)$$

$$z_i \geq t_i + \frac{d_i}{w_2} \gamma, i = 1, 2, \dots, k \quad (1.780)$$

$$z_i \leq t_i + a_i - \frac{\gamma}{w_2} (a_i - d_i), i = 1, 2, \dots, k \quad (1.781)$$

$$z_i \leq t_i + \frac{c_i}{w_3} \beta, i = 1, 2, \dots, k \quad (1.782)$$

$$z_i \leq t_i, i = 1, 2, \dots, k \quad (1.783)$$

$$0 \leq \alpha + \beta + \gamma \leq w_1 + w_2 + w_3; \quad (1.784)$$

$$\alpha \in [0, w_1], \gamma \in [0, w_2], \beta \in [0, w_3]; \quad (1.485)$$

$$w_1 \in [0, 1], w_2 \in [0, 1], w_3 \in [0, 1]; \quad (1.786)$$

$$0 \leq w_1 + w_2 + w_3 \leq 3; \quad (1.787)$$

With the help of generalized truth, indeterminacy, falsity membership function the GNGP based on arithmetic aggregation operator can be formulated as

(P1. 71)

$$\text{Minimize } \left\{ \frac{(1-\alpha) + \beta + (1-\gamma)}{3} \right\} \quad (1.788)$$

subjected to same constraints as (P1.70)

With the help of generalized truth, indeterminacy, falsity membership function ,the GNGP based on geometric aggregation operator can be formulated as

(P1. 72)

$$\text{Minimize } \sqrt[3]{(1-\alpha)\beta(1-\gamma)} \quad (1.789)$$

subjected to same constraints as (P1.70).

Now this non-linear programming problem (P1.70 or P1.71 or P1.72) can be easily solved by an appropriate mathematical programming to give solution of multi-objective non-linear programming problem (P1.65) by GNGP approach.

### 1.37 Application of Neutrosophic Goal Programming to Bank Three Investment Problem

Every investor must trade of return versus risk in deciding how to allocate his or her available funds. The opportunities that promise the greatest profits are almost the ones that present the most serious risks. Commercial banks must be especially careful in balancing return and risk because legal and ethical obligations demand that they avoid profit. This dilemma leads naturally the multi-objective optimization of investment that includes both profit and risk criteria. Our investment example [44] adopts this multi-objective approach to a fictitious Bank Three. Bank Three has a modest \$20 million capital, with \$150 million in demand deposits and \$80 in times deposits (savings accounts and certificates of deposit). Table 1.8 display the categories among which the bank must divide its capital and deposited funds. Rates of return are also provided for each category together with other information related to risk.

**Table 1.8 Bank Three Investment Opportunities**

Investment Category, j	Return Rate(%)	Liquid Part(%)	Required Capital Asset(%)	Risk
Cash	0.0	100.0	0.0	No
Short Term	4.0	99.5	0.5	No
Government:1 to 5 years	4.5	96.0	4.0	No
Government:5 to 10 years	5.5	90.0	5.0	No
Government:over 10 years	7.0	85.0	7.5	No
Installment Loans	10.5	0.0	10.0	Yes

Mortgage Loans	8.5	0.0	10.0	Yes
Commercial Loans	9.2	0.0	10.0	Yes

The first goal of any private business is to maximize profit. Using rates of return from table 1, this produces objective functions

$$\text{Maximize } 0.04I_2 + 0.045I_3 + 0.055I_4 + 0.070I_5 + 0.105I_6 + 0.085I_7 + 0.092I_8 \text{ (Profit)}$$

It is less clear how to quantify investment risk. We employ two common ratio measures. One is the capital –adequacy ratio, expressed as the ratio of required capital for bank solvency to actual capital. A low value indicates minimum risk. The “required capital” rates of table 1 approximate U.S. government formulas used to compute this ratio, and bank Three’s present capital is \$20 million. Thus we will express a second objective

$$\text{Minimize } \frac{1}{20}(0.005I_2 + 0.040I_3 + 0.050I_4 + 0.075I_5 + 0.100I_6 + 0.100I_7 + 0.100I_8) \quad (1.559)$$

Another measure of risk focuses on illiquid risk assets. A low risk asset/capital ratio indicates a financially secure institution. For our example, this third measure of success is expressed as

$$\text{Minimize } \frac{1}{20}(I_6 + I_7 + I_8) \quad (1.790)$$

To complete a bank Three’s investment plans, we must describe the relevant constraints

6. Investments must sum to the available capital and deposited funds.

7. Cash reserves must be at least 14% of demand deposits plus 4% of times deposits.

8. The portion of investments considered should be liquid at least 47% of demand deposits plus 36% of times deposits.

9. At least 30% of funds should be invested in commercial loans, to maintain the bank’s community status.

Combining the 3 objective functions above with these 5 constraints completes a multi-objective linear programming model of Bank Three’s Investment Problem.

**(P1. 83)**

$$\text{Max } PF(I_1, I_2, \dots, I_8) \equiv 0.04I_2 + 0.045I_3 + 0.055I_4 + 0.070I_5 + 0.105I_6 + 0.085I_7 + 0.092I_8$$

(Profit)(1.791)

$$\text{Max } CA(I_1, I_2, \dots, I_8) \equiv \frac{1}{20}(0.005I_2 + 0.040I_3 + 0.050I_4 + 0.075I_5 + 0.100I_6 + 0.100I_7 + 0.100I_8)$$

(Capital-Adequacy)(1.792)

$$\text{Max } RA(I_6, I_7, I_8) \equiv \frac{1}{20}(I_6 + I_7 + I_8) \quad (\text{Risk-Asset})(1.793)$$

Such that

$$IA(I_1, I_2, \dots, I_8) \equiv \frac{1}{20}(I_1 + I_2 + I_3 + I_4 + I_5 + I_6 + I_7 + I_8) = (20150 + 80) \quad (\text{Invest All}) (1.794)$$

$$CR(I_1) \equiv I_1 \geq 0.14(150) + 0.04(80) \quad (\text{Cash Reserve}) (1.795)$$

$$L(I_1, I_2, \dots, I_5) \equiv 1.00I_1 + 0.995I_2 + 0.960I_3 + 0.900I_4 + 0.850I_5 \geq 0.47(150) + 0.36(80) \quad (\text{Liquidity}) (1.796)$$

$$CD_j(I_j) \geq 0.05(20 + 150 + 80) \quad \text{for all } j = 1, 2, \dots, 8 \quad (\text{Diversification}) (1.797)$$

$$C(I_8) \geq 0.30(20 + 150 + 80) \quad (\text{Commercial}) (1.798)$$

$$I_1, I_2, \dots, I_8 \geq 0 \quad (1.799)$$

### 1.38 Numerical Example

Let us consider the input values of membership functions as follows  
 $c_1 = 12, a_1 = 6.67, t_1 = 3, c'_1 = 13, p_1 = 5.67$   $c_2 = 0.58, a_2 = 0.22, t_2 = 0.20, c'_2 = 0.60, p_2 = 0.20$

$$c_3 = 5, a_3 = 1.5, t_3 = 1.0, c'_3 = 5.5, p_3 = 1.0$$

The optimal Bank Three's Investment Problem can be tabulated as

**Table 1.9 Goal Programming Solution of Bank Three Problem**

Weights	Optimal Primal Variables	Optima Objectives
$w_1 = 0.8$ $w_2 = 0.1$ $w_3 = 0.1$	$x_1 = 24.2, x_2 = 12.5,$ $x_3 = 12.5, x_4 = 12.5,$ $x_5 = 46.37, x_6 = 53.43,$ $x_7 = 12.5, x_8 = 24.2$	$f_1 = 18.67363,$ $f_2 = 0.942915, f_3 = 7.096$
$w_1 = 0.05$ $w_2 = 0.9$ $w_3 = 0.05$	$x_1 = 100, x_2 = 12.5,$ $x_3 = 12.5, x_4 = 12.5,$ $x_5 = 12.5, x_6 = 12.5,$ $x_7 = 12.5, x_8 = 75$	$f_1 = 11.9, f_2 = 0.60625,$ $f_3 = 5.00$
$w_1 = 0.1$ $w_2 = 0.1$ $w_3 = 0.8$	$x_1 = 24.2, x_2 = 88.30,$ $x_3 = 12.5, x_4 = 12.5,$ $x_5 = 12.5, x_6 = 12.5,$ $x_7 = 12.5, x_8 = 75$	$f_1 = 14.932, f_2 = 0.6252,$ $f_3 = 5.00$
$w_1 = 1/3$ $w_2 = 1/3$	$x_1 = 24.2, x_2 = 88.30,$	$f_1 = 14.932, f_2 = 0.6252,$



$w_3 = 1/3$	$x_3 = 12.5, x_4 = 12.5,$ $x_5 = 12.5, x_6 = 12.5,$ $x_7 = 12.5, x_1 = 75$	$f_3 = 5.00$
-------------	--	--------------

**Table 1.10 Lexicographic Goal Programming Solution of Bank Three Problem**

Optimal Primal Variables	Optima Objectives
$x_1 = 24.2, x_2 = 22.51454,$	$f_1 = 18.43299,$
$x_3 = 12.5, x_4 = 12.5,$	$f_2 = 0.9100,$
$x_5 = 34.64474,$	$f_3 = 7.182036$
$x_6 = 56.14072, x_7 = 12.5,$	
$x_8 = 24.2$	

### 1.39 Neutrosophic Non-linear Programming (NNLP) Optimization to solve Parameterized Multi-objective Non-linear Programming Problem (PMONLP)

A Multi-Objective Neutrosophic Non-Linear Programming(MONNLP) Problem with imprecise coefficient can be formulated as

**(P1. 84)**

$$\text{Minimize } \tilde{f}_{k_0}^n(x) = \sum_{t=1}^{T_{k_0}} \xi_{k_0^t} \tilde{c}_{k_0^t}^n \prod_{j=1}^n x_j^{a_{k_0^t j}} \quad \text{for } k_0 = 1, 2, \dots, p \quad (1.800)$$

$$\text{Such that } \tilde{f}_i^n(x) = \sum_{t=1}^{T_i} \xi_{it} \tilde{c}_{it}^n \prod_{j=1}^n x_j^{a_{ij}} \leq \xi_i \tilde{b}_i^n \quad \text{for } i = 1, 2, \dots, m \quad (1.801)$$

$$x_j > 0 \quad j = 1, 2, \dots, n \quad (1.802)$$

Here  $\xi_{k_0^t}, \xi_{it}, \xi_i$  are the signum functions used to indicate sign of term in the equation.  $\tilde{c}_{k_0^t} > 0, \tilde{c}_{it} > 0, a_{k_0^t j}, a_{ij}$  are real numbers for all  $i, t, k_0, j$ .

Here

$$\tilde{c}_{k_0^t}^n = \left( (c_{k_0^t}^{1T}, c_{k_0^t}^2, c_{k_0^t}^{3T}; w_{k_0^t}) (c_{k_0^t}^{1I}, c_{k_0^t}^2, c_{k_0^t}^{3I}; \eta_{k_0^t}) (c_{k_0^t}^{1F}, c_{k_0^t}^2, c_{k_0^t}^{3F}; \tau_{k_0^t}) \right); \quad (1.803)$$

$$\tilde{c}_{it}^n = \left( (c_{it}^{1T}, c_{it}^2, c_{it}^{3T}; w_{it}) (c_{it}^{1I}, c_{it}^2, c_{it}^{3I}; \eta_{it}) (c_{it}^{1F}, c_{it}^2, c_{it}^{3F}; \tau_{it}) \right); \quad (1.804)$$

$$\tilde{b}_i^n = \left( (b_i^{1T}, b_i^2, b_i^{3T}; w_i) (b_i^{1I}, b_i^2, b_i^{3I}; \eta_i) (b_i^{1F}, b_i^2, b_i^{3F}; \tau_i) \right) \quad (1.805)$$

Using total integral value of truth, indeterminacy and falsity membership functions we transform above MONNLP with imprecise parameter as

**(P1. 85)**

$$\text{Minimize } \hat{f}_{1k_0}(x; \alpha) = \sum_{t=1}^{T_{k_0}} \xi_{k_0t} \hat{c}_{1k_0t} \prod_{j=1}^n x_j^{a_{k_0tj}} \text{ for } k_0 = 1, 2, \dots, p \quad (1.806)$$

$$\text{Minimize } \hat{f}_{2k_0}(x; \beta) = \sum_{t=1}^{T_{k_0}} \xi_{k_0t} \hat{c}_{2k_0t} \prod_{j=1}^n x_j^{a_{k_0tj}} \text{ for } k_0 = 1, 2, \dots, p \quad (1.807)$$

$$\text{Minimize } \hat{f}_{3k_0}(x; \gamma) = \sum_{t=1}^{T_{k_0}} \xi_{k_0t} \hat{c}_{3k_0t} \prod_{j=1}^n x_j^{a_{k_0tj}} \text{ for } k_0 = 1, 2, \dots, p \quad (1.808)$$

$$\text{Such that } \hat{f}_{1i}(x; \alpha) = \sum_{t=1}^{T_i} \xi_{it} \hat{c}_{1it} \prod_{j=1}^n x_j^{a_{ijt}} \leq \xi_i \hat{b}_{1i} \text{ for } i = 1, 2, \dots, m \quad (1.809)$$

$$\hat{f}_{2i}(x; \beta) = \sum_{t=1}^{T_i} \xi_{it} \hat{c}_{2it} \prod_{j=1}^n x_j^{a_{ijt}} \leq \xi_i \hat{b}_{2i} \text{ for } i = 1, 2, \dots, m \quad (1.810)$$

$$\hat{f}_{3i}(x; \gamma) = \sum_{t=1}^{T_i} \xi_{it} \hat{c}_{3it} \prod_{j=1}^n x_j^{a_{ijt}} \leq \xi_i \hat{b}_{3i} \text{ for } i = 1, 2, \dots, m \quad (1.811)$$

$$x_j > 0; \alpha, \beta, \gamma \in [0, 1] \quad j = 1, 2, \dots, n \quad (1.812)$$

Here  $\xi_{k_0t}$ ,  $\xi_{it}$ ,  $\xi_i$  are the signum functions used to indicate sign of term in the equation.  $\hat{c}_{1k_0t} > 0$ ,  $\hat{c}_{1it} > 0$ ;  $\hat{b}_{1i} > 0$  denote the total integral value of truth membership function i.e

$$\hat{c}_{1k_0t} = \frac{c_{k_0t}^2 + (2w_{k_0t} - 1) \{ \alpha c_{k_0t}^{3\mu} + (1 - \alpha) c_{k_0t}^{1\mu} \}}{2w_{k_0t}}, \quad (1.813)$$

$$\hat{c}_{1it} = \frac{c_{it}^2 + (2w_{it} - 1) \{ \alpha c_{it}^{3\mu} + (1 - \alpha) c_{it}^{1\mu} \}}{2w_{it}} \quad (1.814)$$

$$\text{and } \hat{b}_{1i} = \frac{b_i^2 + (2w_i - 1) \{ \alpha b_i^{3\mu} + (1 - \alpha) b_i^{1\mu} \}}{2w_i} \quad (1.815)$$

and  $\hat{c}_{2k_0t} > 0$ ,  $\hat{c}_{2it} > 0$ ;  $\hat{b}_{2i} > 0$  denote the total integral value of indeterminacy-membership function

$$\text{i.e } \hat{c}_{2k_0t} = \frac{2\eta_{k_0t} c_{k_0t}^{3I} + (1 - 2\beta) \{ c_{k_0t}^2 - c_{k_0t}^{3I} \}}{2\eta_{k_0t}}, \quad (1.816)$$

$$\hat{c}_{2it} = \frac{2\eta_{it} c_{it}^{3I} + (1 - 2\beta) \{ c_{it}^2 - c_{it}^{3I} \}}{2\eta_{it}}, \quad (1.817)$$

$$\text{and } \hat{b}_{2i} = \frac{2\eta_i b_i^{3I} + (1 - 2\beta) \{ b_i^2 - b_i^{3I} \}}{2\eta_i}. \quad (1.818)$$

and  $\hat{c}_{3k_0t} > 0, \hat{c}_{3it} > 0; \hat{b}_{3i} > 0$  denote the total integral value of falsity-membership function i.e

$$\hat{c}_{3k_0t} = \frac{2\tau_{k_0t}c_{k_0t}^{3F} + (1-2\gamma)\{c_{k_0t}^2 - c_{k_0t}^{3F}\}}{2\tau_{k_0t}}, \quad (1.819)$$

$$\hat{c}_{3it} = \frac{2\tau_{it}c_{it}^{3F} + (1-2\gamma)\{c_{it}^2 - c_{it}^{3F}\}}{2\tau_{it}}, \quad (1.820)$$

$$\text{and } \hat{b}_{2i} = \frac{2\tau_i b_i^{3F} + (1-2\gamma)\{b_i^2 - b_i^{3F}\}}{2\tau_i}. \quad (1.821)$$

A Parametric Multi-Objective Non-Linear Neutrosophic Programming (PMONLNP) Problem can be formulated as

**(P1. 86)**

$$\text{Minimize } \{f_1(x; \alpha), \dots, f_p(x; \alpha), f_{p+1}(x; \beta), \dots, f_{2p}(x; \beta), f_{2p+1}(x; \gamma), \dots, f_{3p}(x; \gamma)\}^T \quad (1.822)$$

$$\text{subject to } g_j(x; \alpha) \leq b_j; \quad j = 1, 2, \dots, m \quad (1.823)$$

$$g_j(x; \beta) \leq b_j; \quad j = 1, 2, \dots, m \quad (1.824)$$

$$g_j(x; \gamma) \leq b_j; \quad j = 1, 2, \dots, m \quad (1.825)$$

$$x > 0 \quad \alpha, \beta, \gamma \in [0, 1] \quad (1.826)$$

Following Zimmermann [140], we have presented a solution algorithm to solve the MONLP Problem by fuzzy optimization technique.

**Step-1:** Solve the MONLP (P1.84) as a single objective non-linear programming problem  $p$  times by taking one of the objectives at a time and ignoring the others. These solutions are known as ideal solutions. Let  $x^i$  be the respective optimal solution for the  $i^{\text{th}}$  different objectives with same constraints and evaluate each objective values for all these  $i^{\text{th}}$  optimal solutions.

**Step-2:** From the result of step -1 determine the corresponding values for every objective for each derived solutions. With the values of all objectives at each ideal solutions, pay-off matrix can be formulated as follows

$$\begin{array}{c} f_1(x; \alpha) \quad \dots \quad f_p(x; \alpha) \quad f_{p+1}(x; \beta) \quad \dots \quad f_{2p}(x; \beta) \quad f_{2p+1}(x; \gamma) \quad \dots \quad f_{3p}(x; \gamma) \\ x^1 \left[ \begin{array}{cccccccc} f_1^*(x^1; \alpha) & \dots & f_p^*(x^1; \alpha) & f_{p+1}^*(x^1; \beta) & \dots & f_{2p}^*(x^1; \beta) & f_{2p+1}^*(x^1; \gamma) & \dots & f_{3p}^*(x^1; \gamma) \\ f_1^*(x^2; \alpha) & \dots & f_p^*(x^2; \alpha) & f_{p+1}^*(x^2; \beta) & \dots & f_{2p}^*(x^2; \beta) & f_{2p+1}^*(x^2; \gamma) & \dots & f_{3p}^*(x^2; \gamma) \\ \vdots & \dots & \dots & \dots & \dots & \dots & \dots & \dots & \dots \\ f_1^*(x^{3p}; \alpha) & \dots & f_p^*(x^{3p}; \alpha) & f_{p+1}^*(x^{3p}; \beta) & \dots & f_{2p}^*(x^{3p}; \beta) & f_{2p+1}^*(x^{3p}; \gamma) & \dots & f_{3p}^*(x^{3p}; \gamma) \end{array} \right] \end{array}$$

Here  $x^1, x^2, \dots, x^{3p}$  are the ideal solutions of the objectives  $f_1(x; \alpha), f_2(x; \alpha), \dots, f_p(x; \alpha), f_{p+1}(x; \beta), f_{p+2}(x; \beta), \dots, f_{2p}(x; \beta), f_{2p+1}(x; \gamma), f_{2p+2}(x; \gamma), \dots, f_{3p}(x; \gamma)$  respectively.

**Step-3:** For each objective  $f_k(x; \alpha), f_k(x; \beta), f_k(x; \gamma)$  find lower bound  $L_k^T$  and the upper bound  $U_k^T$ ,

$$U_k^T = \max \{f_k(x^{r*}; p^*)\} \quad (1.827)$$

and

$$L_k^T = \min \{f_k(x^{r*}; p^*)\} \text{ where } p^* = \alpha, \beta, \gamma; k = 1, 2, \dots, 3p \quad (1.828)$$

for truth membership of objectives.

**Step-4:** We represent upper and lower bounds for indeterminacy and falsity membership of objectives as follows :

for  $k = 1, 2, \dots, 3p$

$$U_k^F = U_k^T \text{ and } L_k^F = L_k^T + t(U_k^T - L_k^T); \quad (1.829)$$

$$L_k^I = L_k^T \text{ and } U_k^I = L_k^T + s(U_k^T - L_k^T) \quad (1.830)$$

Here  $t, s$  are predetermined real numbers in  $(0, 1)$

**Step-5:** Define truth membership, indeterminacy membership and falsity membership functions as follows

for  $k = 1, 2, \dots, 3p$

$$T_{f_k(x)}(f_k(x)) = \begin{cases} 1 & \text{if } f_k(x) \leq L_{f_k(x)}^T \\ 1 - \exp \left\{ -\psi \left( \frac{U_{f_k(x)}^T - f_k(x)}{U_{f_k(x)}^T - L_{f_k(x)}^T} \right) \right\} & \text{if } L_{f_k(x)}^T \leq f_k(x) \leq U_{f_k(x)}^T \\ 0 & \text{if } f_k(x) \geq U_{f_k(x)}^T \end{cases} \quad (1.831)$$

$$I_{f_k(x)}(f_k(x)) = \begin{cases} 1 & \text{if } f_k(x) \leq L_{f_k(x)}^I \\ \exp \left\{ \frac{U_{f_k(x)}^I - f_k(x)}{U_{f_k(x)}^I - L_{f_k(x)}^I} \right\} & \text{if } L_{f_k(x)}^I \leq f_k(x) \leq U_{f_k(x)}^I \\ 0 & \text{if } f_k(x) \geq U_{f_k(x)}^I \end{cases} \quad (1.832)$$

$$F_{f(x)}(f(x)) = \begin{cases} 0 & \text{if } f(x) \leq L_{f(x)}^F \\ \frac{1}{2} + \frac{1}{2} \tanh \left\{ \left( f(x) - \frac{U_{f(x)}^F + L_{f(x)}^F}{2} \right) \tau_{f(x)} \right\} & \text{if } L_{f(x)}^F \leq f(x) \leq U_{f(x)}^F \\ 1 & \text{if } f(x) \geq U_{f(x)}^F \end{cases} \quad (1.833)$$

$$\text{Where } \theta_k = \frac{6}{U_k^F - L_k^F} \quad (1.834)$$

$$, \psi = 4 \quad (1.835)$$

**Step-6:** Now NSO method for MONLP problem with probabilistic operator gives an equivalent nonlinear programming problem as:

**(P1. 87)**

$$\text{Maximize } \prod_{i=1}^p (T_i(f_i(x; \alpha))) \prod_{i=p+1}^{2p} (T_i(f_i(x; \beta))) \prod_{i=2p+1}^{3p} (T_i(f_i(x; \gamma))) \quad (1.836)$$

$$\text{Minimize } \prod_{i=1}^p (1 - I_i(f_i(x; \alpha))) \prod_{i=p+1}^{2p} (1 - I_i(f_i(x; \beta))) \prod_{i=2p+1}^{3p} (1 - I_i(f_i(x; \gamma))) \quad (1.837)$$

$$\text{Minimize } \prod_{i=1}^p (1 - F_i(f_i(x; \alpha))) \prod_{i=p+1}^{2p} (1 - F_i(f_i(x; \beta))) \prod_{i=2p+1}^{3p} (1 - F_i(f_i(x; \gamma))) \quad (1.838)$$

subject to

$$0 \leq T_i(f_i(x; \alpha)) + I_i(f_i(x; \alpha)) + F_i(f_i(x; \alpha)) \leq 3 \quad (1.839)$$

$$0 \leq T_i(f_i(x; \beta)) + I_i(f_i(x; \beta)) + F_i(f_i(x; \beta)) \leq 3 \quad (1.840)$$

$$0 \leq T_i(f_i(x; \gamma)) + I_i(f_i(x; \gamma)) + F_i(f_i(x; \gamma)) \leq 3 \quad (1.841)$$

$$g_j(x; \alpha) \leq b_j; g_j(x; \beta) \leq b_j; g_j(x; \gamma) \leq b_j; \quad (1.842)$$

$$x > 0 \quad \alpha, \beta, \gamma \in [0, 1] \quad (1.843)$$

$$i = 1, 2, \dots, p; \quad j = 1, 2, \dots, m$$

This crisp nonlinear programming problem can be solved by appropriate mathematical algorithm.

#### 1.40 Neutrosophic Optimization Technique(NSO) to solve Parametric Single-Objective Non-linear Programming Problem (PSONLP)

A single-objective neutrosophic NLP problem with imprecise co-efficient can be formulated as

**(P1. 88)**

$$\text{Minimize } \tilde{f}(x) = \sum_{t=1}^T \xi_t \tilde{c}_t^n \prod_{j=1}^n x_j^{a_{tj}} \quad (1.844)$$

$$\text{Such that } \tilde{f}_i(x) = \sum_{t=1}^{T_i} \xi_{it} \tilde{c}_{it}^n \prod_{j=1}^n x_j^{a_{tj}} \leq \xi_i \tilde{b}_i^n \text{ for } i = 1, 2, \dots, m \quad (1.845)$$

$$x_j > 0 \quad j = 1, 2, \dots, n \quad (1.846)$$

Here  $\xi_t, \xi_{it}, \xi_i$  are the signum functions used to indicate sign of term in the equation.  $\tilde{c}_t > 0, \tilde{c}_{it} > 0, a_{tj}, a_{ij}$  are real numbers for all  $i, t, j$ .

$$\text{Here } \tilde{c}_t^n = \left( (c_t^{1T}, c_t^{2T}, c_t^{3T}; w_{c_t}), (c_t^{1I}, c_t^{2I}, c_t^{3I}; \eta_{c_t}), (c_t^{1F}, c_t^{2F}, c_t^{3F}; \tau_{c_t}) \right) \quad (1.847)$$

$$\tilde{c}_{it}^n = \left( (c_{it}^{1T}, c_{it}^{2T}, c_{it}^{3T}; w_{c_{it}}), (c_{it}^{1I}, c_{it}^{2I}, c_{it}^{3I}; \eta_{c_{it}}), (c_{it}^{1F}, c_{it}^{2F}, c_{it}^{3F}; \tau_{c_{it}}) \right) \quad (1.848)$$

$$\tilde{b}_i^n = \left( (b_i^{1T}, b_i^{2T}, b_i^{3T}; w_{b_i}), (b_i^{1I}, b_i^{2I}, b_i^{3I}; \eta_{b_i}), (b_i^{1F}, b_i^{2F}, b_i^{3F}; \tau_{b_i}) \right) \quad (1.849)$$

for neutrosophic number coefficient. Using nearest interval approximation method, we transform all the triangular neutrosophic number into interval number i.e  $[c_t^L, c_t^U], [c_{it}^L, c_{it}^U]$ , and  $[b_i^L, b_i^U]$

Now the Single-Objective Neutrosophic Programming (SONSP) with imprecise parameter is of the following form

**(P1. 89)**

$$\text{Minimize } \hat{f}(x) = \sum_{t=1}^T \xi_{k_0 t} \hat{c}_t \prod_{j=1}^n x_j^{a_{tj}} \quad (1.850)$$

$$\text{Such that } \hat{f}_i(x) = \sum_{t=1}^{T_i} \xi_{it} \hat{c}_{it} \prod_{j=1}^n x_j^{a_{tj}} \leq \sigma_i \hat{b}_i \text{ for } i = 1, 2, \dots, m \quad (1.851)$$

$$x_j > 0 \quad j = 1, 2, \dots, n \quad (1.852)$$

Here  $\xi_t, \xi_{it}, \xi_i$  are the signum function used to indicate sign of term in the equation.  $\hat{c}_t > 0,$

$\hat{c}_{it} > 0; \hat{b}_i > 0$  denote the interval component i.e  $\hat{c}_t = [c_t^L, c_t^U], \hat{c}_{it} = [c_{it}^L, c_{it}^U]$ , and  $\hat{b}_i = [b_i^L, b_i^U]$

and  $a_{tj}, a_{ij}$  are real numbers for all  $i, t, j$ .

Using parametric interval valued function the above problem transform into

**(P1. 90)**

$$\text{Minimize } f(x; s) = \sum_{t=1}^T \xi_t (c_t^L)^{1-s} (c_t^U)^s \prod_{j=1}^n x_j^{a_{tj}} \quad (1.853)$$

$$\text{Such that } f_i(x; s) = \sum_{t=1}^{T_i} \xi_{it} (c_{it}^L)^{1-s} (c_{it}^U)^s \prod_{j=1}^n x_j^{a_{ij}} \leq \xi_i (b_i^L)^{1-s} (b_i^U)^s \text{ for } i = 1, 2, \dots, m \quad (1.854)$$

$$x_j > 0 \quad j = 1, 2, \dots, n \quad s \in [0, 1] \quad (1.855)$$

Here  $\xi_i, \xi_{it}, \xi_i$  are the signum functions used to indicate sign of term in the equation.

Let us consider a Single-Objective Nonlinear Optimization Problem (SONLOP) as

**(P1. 91)**

$$\text{Minimize } f(x; s) \quad (1.856)$$

$$g_j(x; s) \leq b_j(s) \quad j = 1, 2, \dots, m \quad (1.857)$$

$$x \geq 0 \quad s \in [0, 1] \quad (1.858)$$

Usually constraint goals are considered as fixed quantity .But in real life problem ,the constraint goal cannot be always exact. So we can consider the constraint goal for less than type constraints at least  $b_j(s)$  and it may possible to extend to  $b_j(s) + b_j^0(s)$ . This fact seems to take the constraint goal as a NS and which will be more realistic descriptions than others. Then the NLP becomes NSO problem with neutrosophic resources, which can be described as follows

**(P1. 92)**

$$\text{Minimize } f(x; s) \quad (1.859)$$

$$g_j(x; s) \leq \tilde{b}_j^n(s) \quad j = 1, 2, \dots, m \quad (1.860)$$

$$x \geq 0 \quad s \in [0, 1] \quad (1.861)$$

To solve the NSO (P1.92), following Werner's [118] and Angelov [3] we are presenting a solution procedure for SONSO problem as follows

**Step-1:** Following Werner's approach solve the single objective non-linear programming problem without tolerance in constraints (i.e  $g_j(x; s) \leq b_j(s)$ ), with tolerance of acceptance in constraints (i.e  $g_j(x; s) \leq b_j(s) + b_j^0(s)$ ) by appropriate non-linear programming technique

Here they are

**(P1. 93)**

**Sub-problem-1**

$$\text{Minimize } f(x; s) \quad (1.862)$$

$$g_j(x; s) \leq b_j(s) \quad j = 1, 2, \dots, m \quad (1.863)$$

$$x \geq 0 \quad (1.864)$$

**(P1. 94)**

**Sub-problem-2**

$$\text{Minimize } f(x; s) \quad (1.865)$$

$$g_j(x; s) \leq b_j(s) + b_j^0(s), \quad j = 1, 2, \dots, m \quad (1.866)$$

$$x \geq 0 \quad (1.867)$$

we may get optimal solutions  $x^* = x^1, f(x^*) = f(x^1)$  and  $x^* = x^2, f(x^*) = f(x^2)$  for sub-problem 1 and 2 respectively.

**Step-2:** From the result of step 1 we now find the lower bound and upper bound of objective functions. If  $U_{f(x;s)}^T, U_{f(x;s)}^I, U_{f(x;s)}^F$  be the upper bounds of truth, indeterminacy, falsity function for the objective respectively and  $L_{f(x;s)}^T, L_{f(x;s)}^I, L_{f(x;s)}^F$  be the lower bounds of truth, indeterminacy, falsity membership functions of objective for particular values of

respectively then  $U_{f(x;s)}^T = \max\{f(x^1; s), f(x^2; s)\}, L_{f(x;s)}^T = \min\{f(x^1; s), f(x^2; s)\},$

$$U_{f(x;s)}^F = U_{f(x;s)}^T, L_{f(x;s)}^F = L_{f(x;s)}^T + t(U_{f(x;s)}^T - L_{f(x;s)}^T) \quad (1.888)$$

$$L_{f(x;s)}^I = L_{f(x;s)}^T, U_{f(x;s)}^I = L_{f(x;s)}^T + q(U_{f(x;s)}^T - L_{f(x;s)}^T) \quad (1.889)$$

Here t, q are predetermined real numbers in (0,1)

**Step-3:** In this step we calculate linear membership for truth, indeterminacy and falsity membership functions of objective as follows

$$T_{f(x;s)}(f(x; s)) = \begin{cases} 1 & \text{if } f(x; s) \leq L_{f(x;s)}^T \\ \left( \frac{U_{f(x;s)}^T - f(x; s)}{U_{f(x;s)}^T - L_{f(x;s)}^T} \right) & \text{if } L_{f(x;s)}^T \leq f(x; s) \leq U_{f(x;s)}^T \\ 0 & \text{if } f(x; s) \geq U_{f(x;s)}^T \end{cases} \quad (1.890)$$

$$I_{f(x;s)}(f(x; s)) = \begin{cases} 1 & \text{if } f(x; s) \leq L_{f(x;s)}^I \\ \left( \frac{U_{f(x;s)}^I - f(x; s)}{U_{f(x;s)}^I - L_{f(x;s)}^I} \right) & \text{if } L_{f(x;s)}^I \leq f(x; s) \leq U_{f(x;s)}^I \\ 0 & \text{if } f(x; s) \geq U_{f(x;s)}^I \end{cases} \quad (1.891)$$



$$F_{f(x;s)}(f(x;s)) = \begin{cases} 0 & \text{if } f(x;s) \leq L_{f(x;s)}^F \\ \frac{f(x;s) - L_{f(x;s)}^F}{U_{f(x;s)}^F - L_{f(x;s)}^F} & \text{if } L_{f(x;s)}^F \leq f(x;s) \leq U_{f(x;s)}^F \\ 1 & \text{if } f(x;s) \geq U_{f(x;s)}^F \end{cases} \quad (1.892)$$

**Step-4:** In this step using linear function for truth, indeterminacy and falsity membership functions, we may calculate membership function for constraints as follows

$$T_{g_j(x;s)}(g_j(x;s)) = \begin{cases} 1 & \text{if } g_j(x;s) \leq b_j \\ \left( \frac{b_j(s) + b_j^0(s) - g_j(x;s)}{b_j^0} \right) & \text{if } b_j(s) \leq g_j(x;s) \leq b_j(s) + b_j^0(s) \\ 0 & \text{if } g_j(x;s) \geq b_j^0(s) \end{cases} \quad (1.893)$$

$$I_{g_j(x;s)}(g_j(x;s)) = \begin{cases} 1 & \text{if } g_j(x;s) \leq b_j(s) \\ \left( \frac{b_j(s) + \xi_{g_j(x;s)} - g_j(x;s)}{\xi_{g_j(x;s)}} \right) & \text{if } b_j(s) \leq g_j(x;s) \leq b_j(s) + \xi_{g_j(x;s)} \\ 0 & \text{if } g_j(x;s) \geq b_j(s) + \xi_{g_j(x;s)} \end{cases} \quad (1.894)$$

$$F_{g_j(x;s)}(g_j(x;s)) = \begin{cases} 0 & \text{if } g_j(x;s) \leq b_j(s) + \varepsilon_{g_j(x;s)} \\ \left( \frac{g_j(x;s) - b_j(s) - \varepsilon_{g_j(x;s)}}{b_j^0(s) - \varepsilon_{g_j(x;s)}} \right) & \text{if } b_j(s) + \varepsilon_{g_j(x;s)} \leq g_j(x;s) \leq b_j(s) + b_j^0(s) \\ 1 & \text{if } g_j(x;s) \geq b_j(s) + b_j^0(s) \end{cases} \quad (1.895)$$

where and for  $j = 1, 2, \dots, m$   $t, q \in (0, 1)$ .

**Step-5:** Now using NSO for single objective optimization technique the optimization problem (P1.92) can be formulated as

**(P1. 95)**

$$\text{Maximize } (\alpha + \gamma - \beta) \quad (1.896)$$

such that

$$T_{f(x;s)}(x;s) \geq \alpha; \quad (1.897)$$

$$T_{g_j}(x;s) \geq \alpha;$$

$$I_{f(x;s)}(x;s) \geq \gamma; \quad (1.898)$$

$$I_{g_j}(x;s) \geq \gamma; \quad (1.899)$$

$$F_{f(x;s)}(x;s) \leq \beta; \quad (1.900)$$

$$F_{g_j}(x;s) \leq \beta; \quad (1.901)$$

$$\alpha + \beta + \gamma \leq 3; \quad (1.902)$$

$$\alpha \geq \beta; \alpha \geq \gamma; \quad (1.903)$$

$$\alpha, \beta, \gamma \in [0,1] \quad s \in [0,1] \quad (1.904)$$

Now the above problem (P1.95) can be simplified to following crisp linear programming problem for linear membership function as

**(P1. 96)**

$$\text{Maximize } (\alpha + \gamma - \beta) \quad (1.905)$$

$$\text{such that } f(x;s) + (U^T - L^T) \cdot \alpha \leq U^T; \quad (1.906)$$

$$f(x;s) + (U_{f(x;s)}^I - L_{f(x;s)}^I) \cdot \gamma \geq U_{f(x;s)}^I; \quad (1.907)$$

$$f(x;s) - (U_{f(x;s)}^F - L_{f(x;s)}^F) \cdot \beta \leq L_{f(x;s)}^F \quad (1.908)$$

$$\alpha + \beta + \gamma \leq 3; \quad (1.909)$$

$$\alpha \geq \beta; \alpha \geq \gamma; \quad (1.910)$$

$$g_j(x;s) + (U^T - L^T) \cdot \alpha \leq U^T; \quad (1.911)$$

$$g_j(x;s) + (U_{g_j(x;s)}^I - L_{g_j(x;s)}^I) \cdot \gamma \geq U_{g_j(x;s)}^I; \quad (1.912)$$

$$g_j(x;s) - (U_{g_j(x;s)}^F - L_{g_j(x;s)}^F) \cdot \beta \leq L_{g_j(x;s)}^F \quad (1.913)$$

$$\alpha, \beta, \gamma \in [0,1] \quad s \in [0,1] \quad j = 1, 2, \dots, m \quad (1.914)$$



# CHAPTER 2

---

## Structural Design Optimization

---

Optimization or in other word mathematical programming is the collection of mathematical principles and methods that have been used for solving several problems in many disciplines, including physics, biology, engineering, economics etc. Engineering is a branch of science where engineers are engaged in formulating different designs with useful objectives. As for examples civil engineers Designs Bridge, pavement and building, mechanical engineers design welded beam design, an electrical engineer designs computer, a chemical engineers design a chemical process. To deal with competitive market place an engineer might not only be interested in design which works at some sort of nominal level but is the best design in some way. The process of determining the best design is called *optimization*.

In mechanics a structure is defined by J.E.Gordon as “any assemblage of materials which is intended to sustain loads”. The structural optimization is the subject of making an assemblage of materials sustains loads in the best way. As for example, let us consider the situation where load is to be transmitted from a region in space to a fixed support in best possible way .Then first specification that comes to our mind to make the structure as light as possible, i.e to minimize weight, secondly stiff as possible and another idea that could be to make it as insensitive to buckling or instability as possible. In case of welded beam design the welding is process of joining metallic parts with the application of heat or pressure or the both, with or without added material. This efficient method for obtaining permanent joints in metallic parts are generally used as a substitute for riveted joint or can be used as an alternative method for casting and forging. Above all, the design of welded beam should be economical (i.e the welding cost is to minimize) and durable one. Similarly Highway construction agencies throughout the globe chasing accelerating demands on durable un dowelled jointed plain concrete pavement (JPCP) due to scanty of rehabilitation of the same. Since decades, different design methods had been developed by various organizations which suit their locale and fix the depth criteria of the JPCP along with other parameters by satisfying the standard code of practice but few of them tries to optimize the design thickness of the same. Moreover few approaches designed such thickness of cited pavement by considering traffic overloading condition, its fatigue life and the fluctuation of ambient temperature effect individually. So

during service life of such pavement, the traffic loads and adverse environmental effect would deteriorate its joints and ultimately its foundation. Therefore optimization of such rigid pavement become essential considering multiple decision making criteria as stated above to make it more durable.

Now such structural optimization and pavement design optimization i.e maximization or minimization cannot be performed without any constraints. For example if there is no limitation of the amount of the material that can be used, the structure can be made stiff without limit and we have an optimization problem without a well-defined solution. So constraints are necessary. Quantities that are usually constrained in structural optimization problem and welded beam design problem are stresses, deflection, buckling load, and or the geometry. The factors governing of JPCP constraints such as fatigue analysis, stresses and deflections , axel loads, pavement thickness, modulus of elasticity of cement concrete, subgrade modulus, Poisson"s ratio, load contact area, annual rate of growth of commercial traffic, number of axel per day, radius of relative stiffness , design period and so on.

Thus we can formulate a optimization problem by picking one of the measures on structural performances as weight, stiffness, critical load, stress, displacement, deflection, geometry or cost of welding or thickness of JPCP as an objective function that should be maximized or minimized and some other measures as constraints. This type of optimization problem is called *single objective optimization* problem. But there is some optimization problem where multiple and conflicting objectives frequently exists .The accomplishment of this task is due to the methodology known as *multi-objective optimization*.

But in the real world, uncertainty or vagueness is prevalent in Engineering Computations. In the context of structural engineering and mechanical engineering design the uncertainty is connected with lack of accurate data of design factors. In case of pavement design several design methods e.g. American Association of State Highway and Transportation Officials(AASHTO), Portland Cement Association (PCA) Method Crop of Engineers of the US army iteration method etc. are available to determine the thickness of JPCP. However all such methods follow numerous monographs, tables and charts to do the same and abiding by certain loop of algorithm in the cited iteration process to find an effective thickness of such pavement. But most of the time, designers stop the cited procedure even after two or three trials which yield safe but unnecessarily less economical thick rigid pavement.

So lots of efforts had been made to get rid of from such problem. As for example finite element method and genetic Algorithm type of crisp optimization method had been applied on the cited subject, where the values of the input parameters were obtained from

experimental data in laboratory scale. Sometimes the above cited standards have already ranged the magnitude of those parameters in between maximum to the minimum value. Therefore, designer get confused to select those input parameters from such ranges which yield imprecise parameters with three key governing factors i.e. degree of acceptance, rejection and hesitancy that attributes the necessity of *Fuzzy Set (FS) theory, Intuitionistic Fuzzy Set (IFS) theory and Neutrosophic Set (NS) theory* For this purpose we will optimize captioned optimum design in *imprecise environment*.

### 2.1S.I Unit Prefixes

Prefix	Symbol	Multiplication Factor
<b>Tera</b>	T	$10^{12}$
<b>Giga</b>	G	$10^9$
<b>Mega</b>	M	$10^6$
<b>Kilo</b>	K	$10^3$
<b>Hector</b>	h	$10^2$
<b>Deka</b>	da	$10^1$
<b>Deci</b>	D	$10^{-1}$
<b>Centi</b>	c	$10^{-2}$
<b>Milli</b>	m	$10^{-3}$
<b>Micro</b>	$\mu$	$10^{-6}$
<b>Nano</b>	n	$10^{-9}$
<b>Pico</b>	p	$10^{-12}$

### 2.2 Conversion of U.S Customary Units to S.I Units

Quantity	Conversion of U.S Customary Unit to S.I. Units	Conversion of S.I. Units to U.S Customary Units
Length	$1\text{ in.} = 25.4\text{ mm} = 0.0254\text{ m}$ $1\text{ ft.} = 304.8\text{ mm} = 0.3048\text{ m}$	$1\text{ mm} = 0.039370\text{ in}$ $1\text{ m} = 39.370\text{ in} = 3.281\text{ ft}$
Area	$1\text{ in}^2 = 645.16\text{ mm}^2$	$1\text{ mm}^2 = 0.001550\text{ in}^2$

	$1 ft^2 = 0.09290304 m^2$	$1 m^2 = 1550 in^2 = 10.764 ft^2$
Volume	$1 in^3 = 16387.064 mm^3$	$1 mm^3 = 0.000061024 in^3$
	$1 ft^3 = 0.028317 m^3$	$1 m^3 = 35.315 ft^3$
Force	$1 lb = 4.45 N$	$1 N = 0.2248 lb$
Stress	$1 psi = 6890 Pa, \left(1 Pa = 1 \frac{N}{m^2}\right)$	$1 Pa = 0.000145 psi$

**Conversion of  $5 \times 10^5 \frac{N}{mm^2}$  to GPa  $\left(1 Pa = 1 \frac{N}{m^2}\right)$**

$$5 \times 10^5 \frac{N}{mm^2} = \frac{5 \times 10^5 \left[ \frac{GN}{10^9} \right]}{\left[ \frac{m}{1000} \right]^2} = 500 Gpa \quad (2.1)$$

**Conversion of  $7 \frac{N}{mm^2}$  to Mpa**

$$7 \frac{N}{mm^2} = \frac{7 \left[ \frac{MN}{10^6} \right]}{\left[ \frac{m}{1000} \right]^2} = 7 \frac{MN}{m^2} = 7 Mpa \quad (2.2)$$

*A tensile bar stretches an amount  $\delta = \frac{P.L}{A.E}$ , where  $P$  is the applied force,  $L$  is the length of the bar,  $A$  is the cross sectional area, and  $E$  is the Young's Modulus. The bar has a circular cross section. Given a load of 60 KN, a length of 70cm, a diameter of, 5mm and a Young's Modulus of 207 Gpa, calculate the deflection in mm*

$$\begin{aligned} \delta &= \frac{P.L}{A.E} = \frac{P.L}{\pi \left(\frac{d}{2}\right)^2 .E} = \frac{4PL}{\pi d^2 E} = \frac{4 \times 60KN \times 70cm}{\pi (5mm)^2 207Gpa} = \frac{4 \times (60 \times 10^3 N) \times (70 \times 10mm)}{\pi (5mm)^2 \left(207 \times \frac{10^9 N}{m^2}\right)} \\ &= \frac{4 \times (60 \times 10^3 N) \times (70 \times 10mm)}{\pi (5mm)^2 \times \left(207 \times \frac{10^9 N}{\left[\frac{mm}{1000}\right]^2}\right)} = 11.81mm \end{aligned} \quad (2.3)$$

### 2.3 Design Studies

In this book we have considered Two-bar truss design, three bar truss design, Jointed plain concrete pavement design and Welded Beam design as structural optimization models. Their formulation have been generated in the following way

### 2.3.1 Two-Bar Truss(Model-I)

A well-known two-bar [Fig.-2.1] planar truss structure is considered. The design objective is to minimize weight of the structural  $WT(A_1, A_2, y_B)$  of a statistically loaded two-bar planar truss subjected to stress  $\sigma_i(A_1, A_2, y_B)$  constraints on each of the truss members  $i = 1, 2$ .

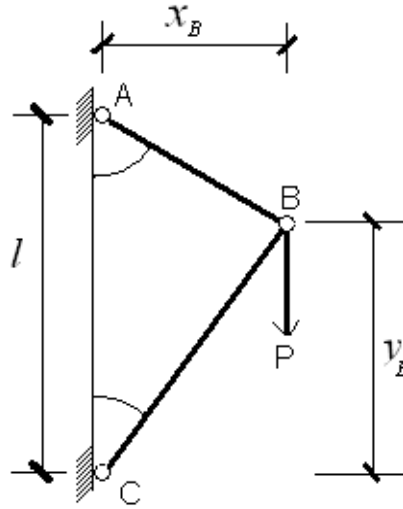

Fig.-2.1 Two-Bar Planar Truss(Model-III)

Optimization model of two-bar truss shown in Fig.-1.1 is designed to support the loading condition. The weight of the structure is

$$WT = (\rho A_1 L_1 + \rho A_2 L_2), \quad (2.4)$$

where  $\rho$  is the material density of the bar  $A_1, A_2$  are the cross sectional area and  $L_1, L_2$  are the length of bar 1 and bar 2 respectively. Length  $AC = l$ , Perpendicular distance from  $AC$  to point load point  $B$  is  $x_B$ , Nodal load =  $P$ . Using simple Pythagorean's theorem we may find the length of the each bars

$$L_1 = \sqrt{x_B^2 + (l - y_B)^2}, \quad (2.5)$$

$$L_2 = \sqrt{x_B^2 + y_B^2}. \quad (2.6)$$

Therefore weight of the structure is

$$WT = \rho \left( A_1 \sqrt{x_B^2 + (l - y_B)^2} + A_2 \sqrt{x_B^2 + y_B^2} \right). \quad (2.7)$$

Let  $P_1$  and  $P_2$  be the reaction forces along the bar 1 and bar 2 respectively. Considering the equilibrium condition at loading point, the following equations are obtained

$$P_1 \cos \theta_1 + P_2 \cos \theta_2 = P, \quad (2.8)$$



$$P_1 \sin \theta_1 - P_2 \sin \theta_2 = 0. \quad (1.6)$$

Solving these two equations we get the axial force on bar 1 as

$$P_1 = \frac{P\sqrt{x_B^2 + (l - y_B)^2}}{l}, \quad (2.9)$$

the axial force on bar 2 as

$$P_2 = -\frac{P\sqrt{x_B^2 + y_B^2}}{l}, \quad (2.10)$$

the stress of bar 1 as

$$\sigma_1 \equiv \frac{P_1}{A_1} = \frac{P\sqrt{x_B^2 + (l - y_B)^2}}{lA_1}, \quad (2.11)$$

i.e tensile stress. the stress of bar 2 as

$$\sigma_2 \equiv \frac{P_2}{A_2} = \frac{P\sqrt{x_B^2 + y_B^2}}{lA_2}, \quad (2.12)$$

i.e compressive stress. As

$$\cos \theta_1 = \frac{l - y_B}{\sqrt{x_B^2 + (l - y_B)^2}}, \quad (2.13)$$

$$\sin \theta_1 = \frac{x_B}{\sqrt{x_B^2 + (l - y_B)^2}}, \quad (2.14)$$

$$\cos \theta_2 = \frac{y_B}{\sqrt{x_B^2 + y_B^2}}, \quad (2.15)$$

$$\sin \theta_1 = \frac{x_B}{\sqrt{x_B^2 + y_B^2}}, \quad (2.16)$$

The single-objective optimization problem can be stated as follows

**(P2.1)**

$$\text{Minimize } WT(A_1, A_2, y_B) = \rho \left( A_1 \sqrt{x_B^2 + (l - y_B)^2} + A_2 \sqrt{x_B^2 + y_B^2} \right) \quad (2.17)$$

Such that

$$\sigma_{AB}(A_1, A_2, y_B) \equiv \frac{P\sqrt{x_B^2 + (l - y_B)^2}}{lA_1} \leq [\sigma_{AB}^T]; \quad (2.18)$$

$$\sigma_{BC}(A_1, A_2, y_B) \equiv \frac{P\sqrt{x_B^2 + y_B^2}}{lA_2} \leq [\sigma_{BC}^C]; \quad (2.19)$$

$$0.5 \leq y_B \leq 1.5; A_1 > 0, A_2 > 0;$$

### 2.3.2 Three-Bar Truss(Model-II)

A well-known three bar planer truss is considered in Fig.2.2 to minimize weight of the structure  $WT(A_1, A_2)$  and minimize the deflection  $\delta(A_1, A_2)$  at a loading point of a statistically loaded three bar planer truss subject to stress constraints on each of the truss members

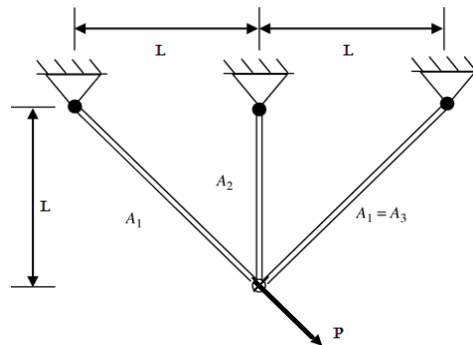

**Fig.-2.2 Three-Bar Planar Truss(Model-I)**

Consider the three-bar truss shown in Fig-2.2. The bars have Young's modulus  $E$  and the lengths are  $l_1 = l_2 = l_3 = L$ . The design variables are cross-sectional areas  $A_1, A_2$  and  $A_3$ . But we assume that  $A_1 = A_3$ . Weight of the structure is

$$WT = \rho l_1 A_1 + \rho l_2 A_2 + \rho l_3 A_3 = \rho L (2\sqrt{2}A_1 + A_2) \quad (2.20)$$

where  $\rho$  is the material density of each bar. The equilibrium equations in the direction x- and y- directions become in matrix form

$$\begin{bmatrix} P_x \\ P_y \end{bmatrix} = \begin{bmatrix} \frac{1}{\sqrt{2}} & 0 & -\frac{1}{\sqrt{2}} \\ \frac{1}{\sqrt{2}} & 1 & \frac{1}{\sqrt{2}} \end{bmatrix} \begin{bmatrix} N_1 \\ N_2 \\ N_3 \end{bmatrix} \quad (2.21)$$

i.e  $F = B^T N$ . Where  $F$  represents the column matrix of external load,  $N$  represents the column matrix of member's forces,  $B^T$  and represents the diagonal matrix of member of stiffness. We cannot obtain bar forces from equilibrium equations alone since the number of bars exceeds the number of degree-of-freedom. In order to find the bar forces, or, rather, that appear in the constraints, we need to make use of Hook's law and geometry conditions. The extension of each bar corresponding to length and force are given in Table 2.1.

**Table 2.1 Extension of Bars of Fig.-2.2**

Bar	Length	Force	Extension
Bar1	$l_1 = \sqrt{2}L$	$N_1$	$e_1 = \frac{N_1 \sqrt{2}L}{A_1 E}$

Bar2	$l_2 = L$	$N_2$	$e_2 = \frac{N_2 L}{A_2 E}$
Bar3	$l_3 = \sqrt{2}L$	$N_3$	$e_3 = \frac{N_3 \sqrt{2}L}{A_1 E}$

we have  $N_i = \frac{EA_i e_i}{l_i} \quad i=1,2,3$  (2.22)

$$\begin{bmatrix} N_1 \\ N_2 \\ N_3 \end{bmatrix} = \begin{bmatrix} \frac{e_1 A_1 E}{\sqrt{2}L} \\ \frac{e_2 A_2 E}{L} \\ \frac{e_3 A_1 E}{\sqrt{2}L} \end{bmatrix} = \frac{E}{L} \begin{bmatrix} \frac{e_1 A_1}{\sqrt{2}} \\ e_2 A_2 \\ \frac{e_3 A_1}{\sqrt{2}} \end{bmatrix}, \quad (2.23)$$

$$\begin{bmatrix} N_1 \\ N_2 \\ N_3 \end{bmatrix} = \frac{E}{L} \begin{bmatrix} \frac{A_1}{\sqrt{2}} & 0 & 0 \\ 0 & A_2 & 0 \\ 0 & 0 & \frac{A_1}{\sqrt{2}} \end{bmatrix} \begin{bmatrix} e_1 \\ e_2 \\ e_3 \end{bmatrix} \quad (2.24)$$

We write these equations for all three bars in matrix form as  $N = De$ , where

$$D = \frac{E}{L} \begin{bmatrix} \frac{A_1}{\sqrt{2}} & 0 & 0 \\ 0 & A_2 & 0 \\ 0 & 0 & \frac{A_1}{\sqrt{2}} \end{bmatrix}, \quad (2.25)$$

$$N = \begin{bmatrix} N_1 \\ N_2 \\ N_3 \end{bmatrix}, \quad (2.26)$$

$$e = \begin{bmatrix} e_1 \\ e_2 \\ e_3 \end{bmatrix} \quad (2.27)$$

The compatibility equations relate the member displacement  $e$  to the nodal displacement  $r$  by  $e = Br$ , the bar forces are obtained as  $N = DBr$ , s. The equilibrium equation

$$N_i = \frac{EA_i e_i}{l_i} \quad i=1,2,3 \quad (2.28)$$

becomes

$$F = B^T N = B^T DBr = Kr \quad (2.29)$$

where  $K = B^T DB$  is global stiffness matrix of the truss, which is

$$K = \begin{bmatrix} \frac{1}{\sqrt{2}} & 0 & -\frac{1}{\sqrt{2}} \\ \frac{1}{\sqrt{2}} & 1 & \frac{1}{\sqrt{2}} \end{bmatrix} \frac{E}{L} \begin{bmatrix} \frac{A_1}{\sqrt{2}} & 0 & 0 \\ 0 & A_2 & 0 \\ 0 & 0 & \frac{A_1}{\sqrt{2}} \end{bmatrix} \begin{bmatrix} \frac{1}{\sqrt{2}} & \frac{1}{\sqrt{2}} \\ 0 & 1 \\ -\frac{1}{\sqrt{2}} & \frac{1}{\sqrt{2}} \end{bmatrix} \quad (2.30)$$

$$= \frac{E}{L} \begin{bmatrix} \frac{A_2}{\sqrt{2}} & -\frac{A_2}{2} \\ -\frac{A_2}{2} & \frac{A_1}{\sqrt{2}} + A_2 \end{bmatrix} \quad (2.31)$$

Thus we obtain the displacement of free node as  $r = K^{-1}F$

$$\begin{bmatrix} r_1 \\ r_2 \end{bmatrix} = \frac{2L}{EA_1(A_1 + \sqrt{2}A_2)} \begin{bmatrix} \frac{A_1}{\sqrt{2}} + A_2 & 0 \\ 0 & \frac{A_1}{2} \end{bmatrix} \begin{bmatrix} P_x \\ P_y \end{bmatrix} = \begin{bmatrix} \frac{\sqrt{2}LP_x}{EA_1} \\ \frac{\sqrt{2}LP_y}{EA_1(A_1 + \sqrt{2}A_2)} \end{bmatrix} \quad (2.32)$$

i.e the horizontal deflection of loaded joint is

$$r_1 = \frac{\sqrt{2}LP_x}{EA_1} \quad (2.33)$$

The vertical deflection of loaded joint is

$$r_2 = \frac{\sqrt{2}LP_y}{E(A_1 + \sqrt{2}A_2)} \quad (2.34)$$

So stresses may be written as

$$\sigma = AN = ADBr \quad (2.35)$$

$$\text{Where } A = \begin{bmatrix} \frac{1}{A_1} & 0 & 0 \\ 0 & \frac{1}{A_2} & 0 \\ 0 & 0 & \frac{1}{A_1} \end{bmatrix} \quad (2.36)$$

$$\begin{bmatrix} \sigma_1 \\ \sigma_2 \\ \sigma_3 \end{bmatrix} = \frac{E}{L} \begin{bmatrix} \frac{1}{2} & \frac{1}{2} \\ 0 & 1 \\ -\frac{1}{2} & \frac{1}{2} \end{bmatrix} \begin{bmatrix} r_1 \\ r_2 \end{bmatrix} = \frac{E}{L} \begin{bmatrix} \frac{1}{2}r_1 + \frac{1}{2}r_2 \\ r_2 \\ -\frac{1}{2}r_1 + \frac{1}{2}r_2 \end{bmatrix} = \begin{bmatrix} \frac{1}{\sqrt{2}} \left( \frac{P_x}{A_1} + \frac{P_y}{(A_1 + \sqrt{2}A_2)} \right) \\ \frac{\sqrt{2}P_y}{(A_1 + \sqrt{2}A_2)} \\ \frac{1}{\sqrt{2}} \left( -\frac{P_x}{A_1} + \frac{P_y}{(A_1 + \sqrt{2}A_2)} \right) \end{bmatrix} \quad (2.37)$$

The tensile stress of bar 1 is

$$\sigma_1 \equiv \frac{1}{\sqrt{2}} \left( \frac{P_x}{A_1} + \frac{P_y}{(A_1 + \sqrt{2}A_2)} \right) \quad (2.38)$$

The tensile stress of bar 2 is

$$\sigma_2 \equiv \frac{\sqrt{2}P_y}{(A_1 + \sqrt{2}A_2)} \quad (2.39)$$

The compressive stress of bar 3 is

$$\sigma_3 \equiv \frac{1}{\sqrt{2}} \left( -\frac{P_x}{A_1} + \frac{P_y}{(A_1 + \sqrt{2}A_2)} \right) \quad (2.40)$$

Considering

$$P_x = P \cos \theta \quad (2.41)$$

$$\text{and } P_y = P \sin \theta \quad (2.42)$$

Assuming  $\theta = 45^\circ$  multi-objective structural design problem, the diagram of which is presented by Fig.-2.2 can be formulated as

**(P2.2)**

$$\text{Minimize } WT(A_1, A_2) = \rho L (2\sqrt{2}A_1 + A_2); \quad (2.43)$$

$$\text{Minimize } \delta(A_1, A_2) = \frac{PL}{E(A_1 + \sqrt{2}A_2)} \quad (2.44)$$

such that

$$\sigma_1(A_1, A_2) = \frac{P(\sqrt{2}A_1 + A_2)}{(\sqrt{2}A_1^2 + 2A_1A_2)} \leq [\sigma_1^T]; \quad (2.45)$$

$$\sigma_2(A_1, A_2) = \frac{P}{(A_1 + \sqrt{2}A_2)} \leq [\sigma_2^T]; \quad (2.46)$$

$$\sigma_3(A_1, A_2) = \frac{PA_2}{(\sqrt{2A_1^2 + 2A_1A_2})} \leq [\sigma_3^C]; \quad (2.47)$$

$$A_i^{\min} \leq A_i \leq A_i^{\max} \quad i = 1, 2$$

### 2.3.3 Design Criteria for Thickness Optimization

The design method of JPCP, presented by Westergaard's Analysis, is the background of current design method of PCA. This method has taken into consideration of fatigue analysis, deflection analysis for subgrade, corner stress analysis in the following way.

#### Fatigue Analysis

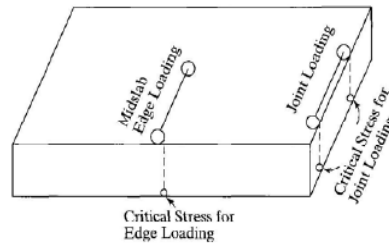

**Fig.-2.3 Typical schematic diagram for fatigue analysis of JPCP**

Fatigue analysis of JPCP is well described in **Report 1-26 (NCHRP, 1990)[88]**, where Damage Ratio ( $DR$ ) have been derived considering curling stress ( $k$ ), sub grade support ( $j$ ) and loading group ( $i$ ) affixed in Eq.(2.48). However, combined effect of all such factor initiates crack in the slab (Fig.- 2.3) while the cited ratio is greater than unity.

$$DR = \sum_{j=1}^p \sum_{k=1}^3 \sum_{i=1}^m \frac{n_{i,k,j}}{N_{i,k,j}} \quad (2.48)$$

Where,  $m$  is the total number of load groups,  $p$  is the number of period in year,  $n_{i,k,j}$  is the predicted number of load repetitions for the  $i$ th load group,  $k$ th curling condition and  $j$ th period whereas  $N_{i,k,j}$  is the allowable number of load repetitions for the same condition . By neglecting the combined effect of warping and curling due to temperature, (2.48) had been transformed into Eq.(2.49).

$$DR = \sum_{i=1}^m \frac{n_i}{N_i} \quad (1.49)$$

Where ( $DR$ ) has been measured by the arithmetic sum of ratio of predicted number of load repetitions for ( $i$ )th load group ( $n_i$ ) to the allowable number of load repetitions for the ( $i$ )th

load group ( $N_i$ ) in between total number of load groups (i.e.  $m$ ). However such ratio at the end of the design period ( $n$ ) should be smaller than unity, (IRC;58-2002)

i.e

$$DR = \sum_{i=1}^m \frac{n_i}{N_i} \leq 1 \quad (2.50)$$

and ( $n_i$ ) of the above equation has been assumed in this study is cumulative number of axels ( $C_i$ ) during the design period defined by

$$C_i = \frac{365 \times A_i \{(1+r)^n - 1\}}{r} \quad (2.51)$$

with  $n, r$  and ( $A_i$ ) as design period in years, annual rate of growth of commercial traffic and initial number of axle per day respectively. However in this study  $N_i$  is replaced by the fatigue life ( $N_f$ ) of JPCP that attributed by the allowable number of load repetitions for the  $i$  th load group ( $N_i$ )

So the Eq.(2.48) has been rearranged in the form as furnished in Eq.(2.52). In this formulation, only two load group (one single axle load and other tandem axle load) i.e.  $m=2$  has been considered,

$$\frac{C_1}{N_1} + \frac{C_2}{N_2} \leq 1 \quad (2.52)$$

Where  $N_1$  and  $N_2$  are fatigue life of the JPCP due to allowable number of load repetitions for single axel as well as tandem axel load respectively. Now fatigue behaviour of cement concrete states that due to repeated application of flexural stresses initiated by the stated loads, progressive fatigue damage takes place in JPCP. However such gradual damage develops akin of micro-cracks especially when the flexural strength of used concrete is high. The ratio between the flexural stress due to load and the flexural strength of concrete is termed as stress ratio ( $SR_i, i=1,2$ ). Now such ratio is majorly influenced by the  $i$  th load group (i.e. single and tandem axel load).

The expression of ( $SR_i, i=1,2$ ), stress ratio for single axle load ( $i=1$ ) and tandem axle load ( $i=2$ ) have been illustrated assuming its contact radius as circle –

$$SR_i(h) = \frac{3(1+\nu)P_i}{\pi(3+\nu)h^2} \left[ \ln\left(\frac{Eh^3}{100ka^4}\right) + 1.84 - \frac{4\nu}{3} + \frac{1-\nu}{2} + \frac{1.18(1+2\nu)a}{l} \right] \text{ for } i=1,2 \quad (2.53)$$

Where  $(\nu)$  and  $(E)$  denote Poisson's ratio and modulus of elasticity of cement concrete respectively.  $l, a, h$  and  $S_f$  denote radius of relative stiffness, radius of load contact areas thickness of the slab and flexural strength of concrete respectively. The relation between  $(N_i)$  and  $(SR_i)$  for single axle load ( $i=1$ ) and tandem axle ( $i=2$ ) is expressed as per IRC 58-2002 below-

$$N_i = \infty \text{ if } SR_i(h) < 0.45 \quad (2.54)$$

$$N_i = \left[ \frac{4.2577}{SR_i(h) - 0.4325} \right]^{3.268} \text{ if } 0.45 < SR_i(h) < 0.55 \quad (2.55)$$

$$N_i = 10^{\left( \frac{0.9718 - SR_i(h)}{0.0828} \right)} \text{ if } SR_i(h) > 0.55 \quad (2.56)$$

Therefore three cases will come up for consideration to demonstrate the stress ratio in terms of fatigue life and axel load.

Case I : When Eq.(2.54) is influenced over the Eq.(2.52), the  $DR$  remain unchanged as Eq.(2.54) as the relation is trivially true

Case II: When Eq.(2.55) is influenced over the Eq.(2.52) the  $DR$  is transforms into

$$F_1(l, h, k, A_1, A_2) \equiv \left[ 365 \times \left\{ (1+r)^n - 1 \right\} \right]^2 \left[ (SR_1(h) - 0.4325)(SR_2(h) - 0.4325) \right]^{3.268} A_1 A_2 \leq (0.5)^2 (4.2577)^{6.536} r^2 \quad (2.57)$$

Case 3: When Eq.(2.56) is influenced over the equation Eq.(2.52), the  $DR$  is expressed as

$$F_2(l, h, k, A_1, A_2) \equiv 2 \text{Log} \left[ \frac{365 \times \left\{ (1+r)^2 - 1 \right\} \times 0.25}{r \times 0.25} \right] + \left( \frac{SR_1(h) + SR_2(h)}{0.0828} \right) - 23.47 \leq \text{Log} (A_1 A_2) \quad (2.58)$$

In the above expression  $A$  is initial number of axle per day in year which is not greater than the sum of initial number of axle per day due to single axle  $A_1$  and initial number of axle per day due to tandem axle  $A_2$ .

## Deflection Analysis for Subgrade



Subgrade strength is expressed in terms of modulus of subgrade ( $k$ ) that has been measured as pressure per unit deflection of the cited subgrade. However if the sustained deflection ( i.e.  $D_{SAL}(k,l)$  and  $D_{TAL}(k,l)$ ) are known for different type of vehicular load at JPCP, such modulus can be represented by Eq.2.59 and Eq.2.60 respectively (Huang, 2004)[50]

$$D_{SAL}(k,l) \equiv \frac{0.431P_1}{kl^2} \left[ 1 - 0.82 \left( \frac{a}{l} \right) \right] \leq d_1 \quad (2.59)$$

and

$$D_{TAL}(k,l) \equiv \frac{0.431P_2}{kl^2} \left[ 1 - 0.82 \left( \frac{a}{l} \right) \right] \leq d_2 \quad (2.60)$$

where  $d_1, d_2$  are the limiting value of deflection of concrete due to single axle load ( $P_1$ ) and tandem axle load ( $P_2$ ) respectively.

### Corner Stress Analysis

In the corner region, the temperature stress is negligible but the load stress is maximum at night when the slab corners have a tendency to lift up, due to warping and lose partly its foundation support as the diagram affixed in Fig.- a, Fig.-b, Fig.-c.

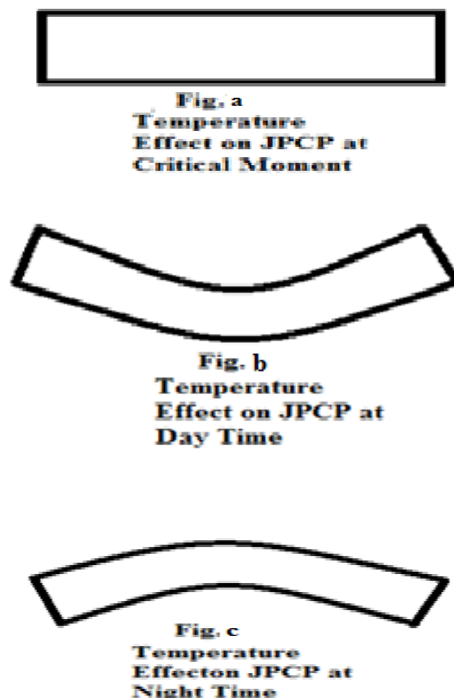

**Fig.-2.4 Temperature Effect of JPCP in Different Time**

Therefore, load stresses (corner stress for single axle,  $S_{SAL}^C(h)$ ; tandem axle load,  $S_{TAL}^C(h)$ ) at

corner region may be obtained as per modified Westergaard's analysis for different types of load groups as per Eq.(2.61), and Eq.(2.62), respectively.

$$S_{SAL}^C(h) \equiv \frac{3P_1}{h^2} \left[ 1 - \left( \frac{a\sqrt{2}}{l} \right)^{1.2} \right] \leq S_f \quad (2.61)$$

$$S_{TAL}^C(h) \equiv \frac{3P_2}{h^2} \left[ 1 - \left( \frac{a\sqrt{2}}{l} \right)^{1.2} \right] \leq S_f \quad (2.62)$$

### Formulation for Optimization of Thickness of Rigid Pavement

The first step of formulation of JPCP is to formulate the pavement optimization problem by defining objective function (minimum thickness) and the constraints (fatigue life consumed, deflection and corner stress due to single and tandem axle) that control the solution.

#### Design input parameters

The input parameters that influence the design are Poisson ratio ( $\nu$ ), Load due to single axle ( $P_1$ ), Load due to tandem axle ( $P_2$ ), Modulus of elasticity of concrete ( $E$ ), Modulus of subgrade reaction ( $k$ ), Radius of load contact areas assumed circular ( $a$ ), Initial number of axles per day in the year ( $A$ ), Design period in year ( $n$ ), Annual rate of growth of commercial traffic ( $r$ ), Limiting value of deflection due to single axle ( $d_1$ ), Limiting value of deflection due to tandem axle ( $d_2$ ), Flexural strength of concrete ( $S_f$ ),

#### Design method

For determining optimum thickness of JPCP, a crisp mathematical model has been formulated. Here Thickness of Slab (TS) has been minimized subjected to a specified set of constraints Eq.(2.62-2.71). Here the optimum design is

#### (P2.3)

$$\text{Minimize } TS(h) \equiv h \quad (2.63)$$

Subject to

$$F_1(l, h, k, A_1, A_2) \equiv \left[ 365 \times \left\{ (1+r)^n - 1 \right\} \right]^2 \left[ (SR_1(h) - 0.4325)(SR_2(h) - 0.4325) \right]^{3.268} A_1 A_2 \leq (0.5)^2 (4.2577)^{6.536} r^2 \quad (2.64)$$

$$F_2(l, h, k, A_1, A_2) \equiv 2 \text{Log} \left[ \frac{365 \times \{(1+r)^2 - 1\} \times 0.25}{r \times 0.25} \right] + \left( \frac{SR_1(h) + SR_2(h)}{0.0828} \right) - 23.47 \leq \text{Log}(A_1 A_2) \quad (2.65)$$

$$D_{SAL}(k, l) \equiv \frac{0.431P_1}{kl^2} \left[ 1 - 0.82 \left( \frac{a}{l} \right) \right] \leq d_1 \quad (2.66)$$

$$D_{TAL}(k, l) \equiv \frac{0.431P_2}{kl^2} \left[ 1 - 0.82 \left( \frac{a}{l} \right) \right] \leq d_2 \quad (2.67)$$

$$S_{SAL}^C(h) \equiv \frac{3P_1}{h^2} \left[ 1 - \left( \frac{a\sqrt{2}}{l} \right)^{1.2} \right] \leq S_f \quad (2.68)$$

$$S_{TAL}^C(h) \equiv \frac{3P_2}{h^2} \left[ 1 - \left( \frac{a\sqrt{2}}{l} \right)^{1.2} \right] \leq S_f \quad (2.69)$$

$$A_{IA}(A_1, A_2) \equiv A_1 + A_2 \leq A \quad (2.70)$$

$$l, h, A_1, A_2 > 0; l_k \leq k \leq u_k \quad (2.71)$$

Where

$$SR_i(h) = \frac{3(1+\nu)P_i}{\pi(3+\nu)h^2} \left[ \ln \left( \frac{Eh^3}{100ka^4} \right) + 1.84 - \frac{4\nu}{3} + \frac{1-\nu}{2} + \frac{1.18(1+2\nu)a}{l} \right] \text{ for } i=1,2 \quad (2.72)$$

### 2.3.4 Welded Beam Design Formulation

The optimum welded beam design(Fig.-2.5) can be formulated considering some design criteria such as cost of welding i.e cost function, shear stress, bending stress and deflection ,derived as follows

#### Cost Function Formulation

The performance index appropriate to this design is the cost of weld assembly. The major cost components of such an assembly are (i) set up labour cost, (ii) welding labour cost, (iii) material cost,i.e

$$C(X) \equiv C_0 + C_1 + C_2 \quad (2.73)$$

where,  $C(X)$  = cost function;  $C_0$  = set up cost;  $C_1$  = welding labour cost;  $C_2$  = material cost.

Now

#### Set Up Cost $C_0$

The company has chosen to make this component a weldment, because of the existence of a welding assembly line. Furthermore, assume that fixtures for set up and holding of the bar

during welding are readily available. The cost  $C_0$  can therefore be ignored in this particular total cost model.

### Welding Labour Cost $C_1$

Assume that the welding will be done by machine at a total cost of \$10/hr (including operating and maintenance expense). Furthermore suppose that the machine can lay down a cubic inch of weld in 6 min. The labour cost is then

$$C_1 = \left(10 \frac{\$}{hr}\right) \left(\frac{1}{60} \frac{\$}{min}\right) \left(6 \frac{min}{in^3}\right) V_w = 1 \left(\frac{\$}{in^3}\right) V_w \quad (2.74)$$

Where  $V_w =$  weld volume,  $in^3$

### Material Cost $C_2$

$$C_2 = C_3 V_w + C_4 V_B$$

Where  $C_3 =$  cost per volume per weld material,  $\$/in^3 = (0.37)(0.283)$  ;  $C_4 =$  cost per volume of bar stock,  $\$/in^3 = (0.37)(0.283)$  ;  $V_B =$  volume of bar,  $in^3$ .

From geometry  $V_w = h^2 l$  ; volume of the weld material,  $in^3$  ;  $V_{weld} = x_1^2 x_2$  and  $V_B = tb(L+l)$  ; volume of bar,  $in^3$   $V_{bar} = x_3 x_4 (L + x_2)$  .

Therefore cost function become

$$C(X) = h^2 l + C_3 h^2 l + C_4 tb(L+l) = 1.10471 x_1^2 x_2 + 0.04811 x_3 x_4 (14.0 + x_2) \quad (2.75)$$

### Constraints Derivation from Engineering Relationship

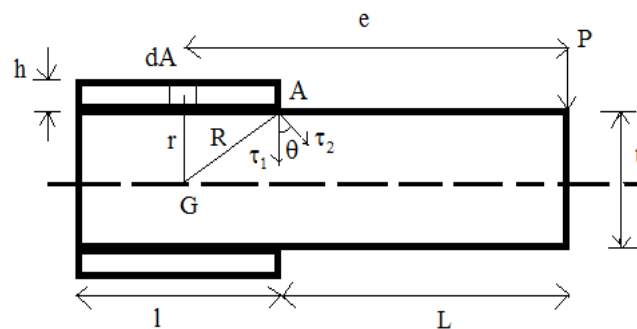

Fig.-2.5 Shear Stresses in the Weld Group.

#### Maximum shear stress in weld group

To complete the model it is necessary to define important stress states

Direct or primary shear stress i.e

$$\tau_1 = \frac{Load}{Throat\ area} = \frac{P}{A} = \frac{P}{\sqrt{2}hl} = \frac{P}{\sqrt{2}x_1 x_2} \quad (2.76)$$

Since the shear stress produced due to turning moment  $M = P.e$  at any section, is proportional to its radial distance from centre of gravity of the joint „G“, therefore stress due

to  $M$  is proportional to  $R$  and is in a direction at right angles to  $R$ . In other words

$$\frac{\tau_2}{R} = \frac{\tau}{r} = \text{constant} \quad (2.77)$$

$$\text{Therefore } R = \sqrt{\left(\frac{l}{2}\right)^2 + \left(\frac{h+t}{2}\right)^2} = \sqrt{\frac{x_2^2}{4} + \frac{(x_1+x_3)^2}{4}} \quad (2.78)$$

Where,  $\tau_2$  is the shear stress at the maximum distance  $R$  and  $\tau$  is the shear stress at any distance  $r$ . Consider a small section of the weld having area  $dA$  at a distance  $r$  from „G“. Therefore shear force on this small section  $= \tau \times dA$  and turning moment of the shear force about centre of gravity is

$$dM = \tau \times dA \times r = \frac{\tau_2}{R} \times dA \times r^2 \quad (2.79)$$

Therefore total turning moment over the whole weld area

$$M = \frac{\tau_2}{R} \int dA \times r^2 = \frac{\tau_2}{R} J. \quad (2.80)$$

where  $J$  = polar moment of inertia of the weld group about centre of gravity.

Therefore shear stress due to the turning moment i.e.

$$\text{Secondary shear stress, } \tau_2 = \frac{MR}{J} \quad (2.81)$$

In order to find the resultant stress, the primary and secondary shear stresses are combined vectorially. Therefore the maximum resultant shear stress that will be produced at the weld

$$\text{group, } \tau = \sqrt{\tau_1^2 + \tau_2^2 + 2\tau_1\tau_2 \cos \theta}, \quad (2.82)$$

where,  $\theta$  = angle between  $\tau_1$  and  $\tau_2$ .

$$\text{As } \cos \theta = \frac{l/2}{R} = \frac{x_2}{2R}; \quad (2.83)$$

$$\tau = \sqrt{\tau_1^2 + \tau_2^2 + 2\tau_1\tau_2 \frac{x_2}{2R}}. \quad (2.84)$$

Now the polar moment of inertia of the throat area ( $A$ ) about the centre of gravity is obtained by parallel axis theorem,

$$J = 2 \left[ I_{xx} + A \times x^2 \right] = 2 \left[ \frac{A \times l^2}{12} + A \times x^2 \right] = 2A \left( \frac{l^2}{12} + x^2 \right) = 2 \left\{ \sqrt{2}x_1x_2 \left[ \frac{x_2^2}{12} + \frac{(x_1+x_3)^2}{2} \right] \right\} \quad (2.85)$$

Where,  $A$  = throat area  $= \sqrt{2}x_1x_2$ ,  $l$  = Length of the weld,

$$x = \text{Perpendicular distance between two parallel axes} = \frac{t}{2} + \frac{h}{2} = \frac{x_1+x_3}{2} \quad (2.86)$$

### Maximum bending stress in beam

Now Maximum bending moment =  $PL$ , Maximum bending stress =  $\frac{T}{Z}$ , where  $T = PL$ ;

$Z =$  section modulus =  $\frac{I}{y}$ ;  $I =$  moment of inertia =  $\frac{bt^3}{12}$ ;  $y =$  distance of extreme fibre from centre of gravity of cross section =  $\frac{t}{2}$ ; Therefore  $Z = \frac{bt^2}{6}$ .

$$\text{So bar bending stress } \sigma(x) = \frac{T}{Z} = \frac{6PL}{bt^2} = \frac{6PL}{x_4 x_3^2}. \quad (2.87)$$

### Maximum deflection in beam

$$\text{Maximum deflection at cantilever tip } \delta(x) = \frac{PL^3}{3EI} = \frac{PL^3}{3E \frac{bt^3}{12}} = \frac{4PL^3}{Ebt^3} = \frac{4PL^3}{Ex_4 x_3^2} \quad (2.88)$$

### Buckling load of beam

$$\text{Buckling load can be approximated by } P_c(x) = \frac{4.013\sqrt{EIC}}{l^2} \left(1 - \frac{a}{l} \sqrt{\frac{EI}{C}}\right) \quad (2.89)$$

$$= \frac{4.013\sqrt{E \frac{t^2 b^6}{36}}}{L^2} \left(1 - \frac{t}{2L} \sqrt{\frac{E}{4G}}\right) = \frac{4.013\sqrt{EGx_3^6 x_4^6 / 36}}{L^2} \left(1 - \frac{x_3}{2L} \sqrt{\frac{E}{4G}}\right) \quad (2.90)$$

where,  $I =$  moment of inertia =  $\frac{bt^3}{12}$ ; torsional rigidity  $C = GJ = \frac{1}{3}tb^3G$ ;  $l = L$ ;  $a = \frac{t}{2}$ .

### Crisp Formulation of Welded Beam Design

In design formulation a welded beam (Fig. -2.6) has to be designed at minimum cost whose constraints are shear stress in weld ( $\tau$ ), bending stress in the beam ( $\sigma$ ), buckling load on the

bar ( $P$ ), and deflection of the beam ( $\delta$ ). The design variables are  $\begin{bmatrix} x_1 \\ x_2 \\ x_3 \\ x_4 \end{bmatrix} = \begin{bmatrix} h \\ l \\ t \\ b \end{bmatrix}$  where  $h$  is the

weld size,  $l$  is the length of the weld,  $t$  is the depth of the welded beam,  $b$  is the width of the welded beam.

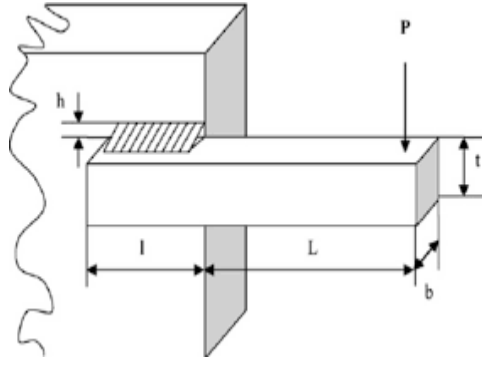

**Fig.-2.6 Design of the welded beam**

The single-objective crisp welded beam optimization problem can be formulated as follows

**(P2.4)**

$$\text{Minimize } C(X) \equiv 1.10471x_1^2x_2 + 0.04811(14 + x_2)x_3x_4 \quad (2.91)$$

such that

$$g_1(x) \equiv \tau(x) - \tau_{\max} \leq 0 \quad (2.92)$$

$$g_2(x) \equiv \sigma(x) - \sigma_{\max} \leq 0 \quad (2.93)$$

$$g_3(x) \equiv x_1 - x_4 \leq 0 \quad (2.94)$$

$$g_4(x) \equiv 0.10471x_1^2x_2 + 0.04811x_3x_4(14 + x_2) - 5 \leq 0 \quad (2.95)$$

$$g_5(x) \equiv 0.125 - x_1 \leq 0 \quad (2.96)$$

$$g_6(x) \equiv \delta(x) - \delta_{\max} \leq 0 \quad (2.97)$$

$$g_7(x) \equiv P - P_C(x) \leq 0 \quad (2.98)$$

$$x_1, x_2, x_3, x_4 \in [0, 1] \quad (2.99)$$

$$\text{where } \tau(x) = \sqrt{\tau_1^2 + 2\tau_1\tau_2 \frac{x_2}{2R} + \tau_2^2} \quad ; \quad \tau_1 = \frac{P}{\sqrt{2}x_1x_2} ; \tau_2 = \frac{MR}{J} ; M = P\left(L + \frac{x_2}{2}\right) ;$$

$$R = \sqrt{\frac{x_2^2}{4} + \left(\frac{x_1 + x_3}{2}\right)^2} ; J = \left\{ \frac{x_1x_2}{\sqrt{2}} \left[ \frac{x_2^2}{12} + \left(\frac{x_1 + x_3}{2}\right)^2 \right] \right\} ; \sigma(x) = \frac{6PL}{x_4x_3^2} ; \delta(x) = \frac{4PL^3}{Ex_4x_3^2} ;$$

$$P_C(x) = \frac{4.013\sqrt{EGx_3^6x_4^6/36}}{L^2} \left( 1 - \frac{x_3}{2L} \sqrt{\frac{E}{4G}} \right) \text{ as derived as Eq.(2.82), Eq.(2.76), Eq.(2.81),}$$

Eq.(2.80), Eq. (2.78), Eq. (2.85), Eq. (2.87), Eq. (2.88), Eq. (2.90), respectively. Again  $P$  = Force on beam ;  $L$  = Beam length beyond weld;  $x_1$  = Height of the welded beam;  $x_2$  = Length of the welded beam;  $x_3$  = Depth of the welded beam;  $x_4$  = Width of the welded beam;  $\tau(x)$  = Design shear stress;  $\sigma(x)$  = Design normal stress for beam material;  $M$  = Moment of

$P$  about the centre of gravity of the weld ,  $J$  = Polar moment of inertia of weld group;  $G$  = Shearing modulus of Beam Material;  $E$  = Young modulus;  $\tau_{\max}$  = Design Stress of the weld;  $\sigma_{\max}$  = Design normal stress for the beam material;  $\delta_{\max}$  = Maximum deflection;  $\tau_1$  = Primary stress on weld throat.  $\tau_2$  = Secondary torsional stress on weld.



# CHAPTER 3

---

## **Truss Design Optimization using Neutrosophic Optimization Technique: A Comparative Study**

---

The research area of optimal structural design has been receiving increasing attention from both academia and industry over the past four decades in order to improve structural performance and to reduce design costs. However, in the real world, uncertainty or vagueness is prevalent in the Engineering Computations. In the context of structural design the uncertainty is connected with lack of accurate data of design factors. This problem has been solving by use of fuzzy mathematical algorithm for dealing with this class of problems. Fuzzy set (FS) theory has long been introduced to deal with inexact and imprecise resources by Zadeh [133], as an application, Bellman and Zadeh [10] used the FS theory to the decision making problem. In such extension, Atanassov [1] introduced Intuitionistic Fuzzy set (IFS) which is one of the generalizations of FS theory and is characterized by a membership function, a non membership function and a hesitancy function. In FS the degree of acceptance is only considered but IFS is characterized by a degree of acceptance and degree of rejection so that their sum is less than one. As a generalization of FS and IFS, F. Smrandache [94] introduced a new notion which is known as neutrosophic set (NS in short) in 1995. NS is characterized by degree of truth membership, degree of indeterminacy membership and degree of falsity membership. The concept of NS generates the theory of neutrosophic sets by expressing indeterminacy of imprecise information. This theory is considered as complete representation of structural design problems like other decision making problems. Therefore, if uncertainty is involved in a structural model, we use fuzzy theory while dealing indeterminacy, we need neutrosophic theory. This is the first time NSO technique is applied in structural design. Several researchers like Wang et al. [119] first applied  $\alpha$ -cut method to structural designs where the non-linear problems were solved with various design levels  $\alpha$ , and then a sequence of solutions were obtained by setting different level-cut value of  $\alpha$ . To design a four-bar mechanism for function generating problem, Rao [89] used the same  $\alpha$ -cut method.

Structural optimization with fuzzy parameters was developed by Yeh et al. [131]. Xu [13] used two-phase method for Fuzzy Optimization (FO) of structures. A level-cut of the first and second kind approach used by Shih et al. [95] for structural design optimization problems with fuzzy resources. Shih et al. [96] developed alternative  $\alpha$ -level-cuts methods for optimum structural design with fuzzy resources. Dey et al. [32] used generalized fuzzy number in context of a structural design. Dey et al. [33] developed parameterized t-norm based FO method for optimum structural design. Also, a parametric geometric programming is introduced by Dey et.al [34] to Optimize shape design of structural model with imprecise coefficient. A transportation model was solved by Jana et al.[57] using multi-objective intuitionistic fuzzy linear programming. Dey et al. [35] solved two bar truss non linear problem by using Intuitionistic Fuzzy Optimization (IFO) problem. Dey et al. [36] used IFO technique for multi objective optimum structural design. R-x Liang et al.[66] applied interdependent inputs of single valued trapezoidal neutrosophic information on Multi-criteria group decision making problem. P Ji et al. [58], S Yu et al. [132] did so many research study on application based neutrosophic sets and intuitionistic linguistic number . Z-p Tian et al.[115] Simplified neutrosophic linguistic multi-criteria group decision-making approach to green product development. Again J-j Peng et al.[81] introduced multi-valued neutrosophic qualitative flexible approach based on likelihood for multi-criteria decision-making problems.Also H Zhang et al [135] investigates a case study on a novel decision support model for satisfactory restaurants utilizing social information. P Ji et al. [58] developed a projection-based TODIM method under multi-valued neutrosophic environments and its application in personnel selection.

The present study investigates computational algorithm for solving single-objective structural problem by single valued Neutrosophic Optimization (NSO) approach. The impact of linear and nonlinear truth, indeterminacy and falsity membership functions in such optimization process also has been studied here. A comparison is made numerically among FO, IFO and NSO technique. From our numerical result, it is clear that NSO technique provides better results than FO as well as IFO.

### **3.1 General Formulation of Single-objective Structural Model**

In sizing optimization problems, the aim is to minimize single objective function, usually the weight of the structure under certain behavioural constraints which are displacement or stresses. The design variables are most frequently chosen to be dimensions of the cross

sectional areas of the members of the structures. Due to fabrications limitations the design variables are not continuous but discrete for belongingness of cross-sections to a certain set. A discrete structural optimization problem can be formulated in the following form

**(P3.1)**

$$\text{Minimize } WT(A) \quad (3.1)$$

$$\text{subject to } \sigma_i(A) \leq [\sigma_i(A)], i = 1, 2, \dots, m \quad (3.2)$$

$$A_j \in R^d, \quad j = 1, 2, \dots, n \quad (3.3)$$

where  $WT(A)$  represents objective function,  $\sigma_i(A)$  is the behavioural constraints and  $[\sigma_i(A)]$  denotes the maximum allowable value,  $m$  and  $n$  are the number of constraints and design variables respectively. A given set of discrete value is expressed by  $R^d$  and in this paper objective function is taken as

$$WT(A) = \sum_{i=1}^m \rho_i l_i A_i \quad (3.4)$$

and constraint are chosen to be stress of structures as follows

$$\sigma_i(A) \leq \sigma_i \text{ with allowable tolerance } \sigma_i^0 \text{ for } i = 1, 2, \dots, m \quad (3.5)$$

Where  $\rho_i$  and  $l_i$  are weight of unit volume and length of  $i^{th}$  element respectively,  $m$  is the number of structural element,  $\sigma_i$  and  $\sigma_i^0$  are the  $i^{th}$  stress, allowable stress respectively

### 3.2 Neutrosophic Optimization Technique to Solve Single-objective Structural Optimization Problem (SOSOP)

To solve the SOSOP (P3.1), step 1 of 1.29 is used and we will get optimum solutions of two sub problem as  $A^1$  and  $A^2$ . After that according to step 2 we find upper and lower bound of membership function of objective function as  $U_{WT(A)}^T, U_{WT(A)}^I, U_{WT(A)}^F$  and  $L_{WT(A)}^T, L_{WT(A)}^I, L_{WT(A)}^F$

$$\text{where } U_{WT(A)}^T = \max \{WT(A^1), WT(A^2)\}, \quad (3.6)$$

$$L_{WT(A)}^T = \min \{WT(A^1), WT(A^2)\}, \quad (3.7)$$

for Model-I, II-AL, AN

$$U_{WT(A)}^F = U_{WT(A)}^T, L_{WT(A)}^F = L_{WT(A)}^T + \varepsilon_{WT(A)} \text{ where } 0 < \varepsilon_{WT(A)} < (U_{WT(A)}^T - L_{WT(A)}^T) \quad (3.8)$$

$$L_{WT(A)}^I = L_{WT(A)}^T, U_{WT(A)}^I = L_{WT(A)}^T + \xi_{WT(A)} \text{ where } 0 < \xi_{WT(A)} < (U_{WT(A)}^T - L_{WT(A)}^T) \quad (3.9)$$

for Model-I,II-BL,BN

$$U_{WT(A)}^F = U_{WT(A)}^T = U_{WT(A)}^I$$

$$L_{WT(A)}^F = L_{WT(A)}^T - \varepsilon_{WT(A)} \text{ where } 0 < \varepsilon_{WT(A)} < (U_{WT(A)}^T - L_{WT(A)}^T)$$

$$L_{WT(A)}^I = L_{WT(A)}^T - \xi_{WT(A)} \text{ where } 0 < \xi_{WT(A)} < (U_{WT(A)}^T - L_{WT(A)}^T)$$

Let the linear membership function for objective be

$$T_{WT(A)}(WT(A)) = \begin{cases} 1 & \text{if } WT(A) \leq L_{WT(A)}^T \\ \left( \frac{U_{WT(A)}^T - WT(A)}{U_{WT(A)}^T - L_{WT(A)}^T} \right) & \text{if } L_{WT(A)}^T \leq WT(A) \leq U_{WT(A)}^T \\ 0 & \text{if } WT(A) \geq U_{WT(A)}^T \end{cases} \quad (3.10)$$

For Model-I,II-AL

$$I_{WT(A)}(WT(A)) = \begin{cases} 1 & \text{if } WT(A) \leq L_{WT(A)}^T \\ \left( \frac{(L_{WT(A)}^T + \xi_{WT(A)}) - WT(A)}{\xi_{WT(A)}} \right) & \text{if } L_{WT(A)}^T \leq WT(A) \leq L_{WT(A)}^T + \xi_{WT(A)} \\ 0 & \text{if } WT(A) \geq L_{WT(A)}^T + \xi_{WT(A)} \end{cases} \quad (3.11)$$

For Model-I,II-BL

$$I_{WT(A)}(WT(A)) = \begin{cases} 1 & \text{if } WT(A) \geq U_{WT(A)}^T \\ \left( \frac{WT(A) - (L_{WT(A)}^T + \xi_{WT(A)})}{U_{WT(A)}^T - L_{WT(A)}^T - \xi_{WT(A)}} \right) & \text{if } L_{WT(A)}^T + \xi_{WT(A)} \leq WT(A) \leq U_{WT(A)}^T \\ 0 & \text{if } WT(A) \leq L_{WT(A)}^T + \xi_{WT(A)} \end{cases} \quad (3.12)$$

$$F_{WT(A)}(WT(A)) = \begin{cases} 0 & \text{if } WT(A) \leq L_{WT(A)}^T + \varepsilon_{WT(A)} \\ \left( \frac{WT(A) - (L_{WT(A)}^T + \varepsilon_{WT(A)})}{U_{WT(A)}^T - L_{WT(A)}^T - \varepsilon_{WT(A)}} \right) & \text{if } L_{WT(A)}^T + \varepsilon_{WT(A)} \leq WT(A) \leq U_{WT(A)}^T \\ 1 & \text{if } WT(A) \geq U_{WT(A)}^T \end{cases} \quad (3.13)$$

and constraints be

$$T_{\sigma_i(A)}(\sigma_i(A)) = \begin{cases} 1 & \text{if } \sigma_i(A) \leq L_{\sigma_i}^T \\ \left( \frac{U_{\sigma_i}^T - \sigma_i(A)}{U_{\sigma_i}^T - L_{\sigma_i}^T} \right) & \text{if } L_{\sigma_i}^T \leq \sigma_i(A) \leq U_{\sigma_i}^T \\ 0 & \text{if } \sigma_i(A) \geq U_{\sigma_i}^T \end{cases} \quad (3.14)$$

For Model-I,II-AL

$$I_{\sigma_i(A)}(\sigma_i(A)) = \begin{cases} 1 & \text{if } \sigma_i(A) \leq L_{\sigma_i}^T \\ \left( \frac{(L_{\sigma_i}^T + \xi_{\sigma_i(x)}) - \sigma_i(A)}{\xi_{\sigma_i(x)}} \right) & \text{if } L_{\sigma_i}^T \leq \sigma_i(A) \leq L_{\sigma_i}^T + \xi_{\sigma_i(x)} \\ 0 & \text{if } \sigma_i(A) \geq L_{\sigma_i}^T + \xi_{\sigma_i(x)} \end{cases} \quad (3.15)$$

For Model-I,II-BL

$$I_{\sigma_i(A)}(\sigma_i(A)) = \begin{cases} 1 & \text{if } \sigma_i(A) \geq U_{\sigma_i}^T \\ \left( \frac{\sigma_i(A) - (L_{\sigma_i}^T + \xi_{\sigma_i(x)})}{U_{\sigma_i}^T - L_{\sigma_i}^T - \xi_{\sigma_i(x)}} \right) & \text{if } L_{\sigma_i}^T + \xi_{\sigma_i(x)} \leq \sigma_i(A) \leq U_{\sigma_i}^T \\ 0 & \text{if } \sigma_i(A) \leq L_{\sigma_i}^T + \xi_{\sigma_i(x)} \end{cases} \quad (3.16)$$

$$F_{\sigma_i(A)}(\sigma_i(A)) = \begin{cases} 0 & \text{if } \sigma_i(A) \leq L_{\sigma_i}^T + \varepsilon_{\sigma_i(x)} \\ \left( \frac{\sigma_i(A) - L_{\sigma_i}^T - \varepsilon_{\sigma_i(x)}}{U_{\sigma_i}^T - L_{\sigma_i}^T - \varepsilon_{\sigma_i(x)}} \right) & \text{if } L_{\sigma_i}^T + \varepsilon_{\sigma_i(x)} \leq \sigma_i(A) \leq U_{\sigma_i}^T \\ 1 & \text{if } \sigma_i(A) \geq U_{\sigma_i}^T \end{cases} \quad (3.17)$$

where for  $j=1,2,\dots,m$   $0 < \varepsilon_{\sigma_i(x)}, \xi_{\sigma_i(A)} < \sigma_i^0$

and if non-linear membership function be considered for objective function  $WT(A)$  then

$$T_{WT(A)}(WT(A)) = \begin{cases} 1 & \text{if } WT(A) \leq L_{WT(A)}^T \\ 1 - \exp\left\{-\psi\left(\frac{U_{WT(A)}^T - WT(A)}{U_{WT(A)}^T - L_{WT(A)}^T}\right)\right\} & \text{if } L_{WT(A)}^T \leq WT(A) \leq U_{WT(A)}^T \\ 0 & \text{if } WT(A) \geq U_{WT(A)}^T \end{cases} \quad (3.18)$$

For Model-I,II-AN

$$I_{WT(A)}(WT(A)) = \begin{cases} 1 & \text{if } WT(A) \leq L_{WT(A)}^T \\ \exp\left\{\frac{(L_{WT(A)}^T + \xi_{WT}) - WT(A)}{\xi_{WT}}\right\} & \text{if } L_{WT(A)}^T \leq WT(A) \leq L_{WT(A)}^T + \xi_{WT} \\ 0 & \text{if } WT(A) \geq L_{WT(A)}^T + \xi_{WT} \end{cases} \quad (3.19)$$

For Model-I,II-BN

$$I_{WT(A)}(WT(A)) = \begin{cases} 1 & \text{if } WT(A) \geq U_{WT(A)}^T \\ \exp\left\{\frac{WT(A) - (L_{WT(A)}^T + \xi_{WT})}{U_{WT(A)}^T - L_{WT(A)}^T - \xi_{WT}}\right\} & \text{if } L_{WT(A)}^T + \xi_{WT} \leq WT(A) \leq U_{WT(A)}^T \\ 0 & \text{if } WT(A) \leq L_{WT(A)}^T + \xi_{WT} \end{cases} \quad (3.20)$$

$$F_{WT(A)}(WT(A)) = \begin{cases} 0 & \text{if } WT(A) \leq L_{WT(A)}^T + \varepsilon_{WT} \\ \frac{1}{2} + \frac{1}{2} \tanh\left\{\left(WT(A) - \frac{(U_{WT(A)}^T + L_{WT(A)}^T) + \varepsilon_{WT}}{2}\right) \tau_{WT}\right\} & \text{if } L_{WT(A)}^T + \varepsilon_{WT} \leq WT(A) \leq U_{WT(A)}^T \\ 1 & \text{if } WT(A) \geq U_{WT(A)}^T \end{cases} \quad (3.21)$$

where  $0 < \varepsilon_{WT}, \xi_{WT} < (U_{WT}^T - L_{WT}^T)$  and if nonlinear truth, indeterminacy and falsity membership functions be considered for constraints then

$$T_{\sigma_i(A)}(\sigma_i(A)) = \begin{cases} 1 & \text{if } \sigma_i(A) \leq L_{\sigma_i}^T \\ 1 - \exp\left\{-\psi\left(\frac{U_{\sigma_i}^T - \delta(A)}{U_{\sigma_i}^T - L_{\sigma_i}^T}\right)\right\} & \text{if } L_{\sigma_i}^T \leq \sigma_i(A) \leq U_{\sigma_i}^T \\ 0 & \text{if } \sigma_i(A) \geq U_{\sigma_i}^T \end{cases} \quad (3.22)$$

For Model-I,II-AN

$$I_{\sigma_i(A)}(\sigma_i(A)) = \begin{cases} 1 & \text{if } \sigma_i(A) \leq L_{\sigma_i}^T \\ \exp\left\{\frac{(L_{\sigma_i}^T + \xi_{\sigma_i}) - \sigma_i(A)}{\xi_{\sigma_i}}\right\} & \text{if } L_{\sigma_i}^T \leq \sigma_i(A) \leq L_{\sigma_i}^T + \xi_{\sigma_i} \\ 0 & \text{if } \sigma_i(A) \geq L_{\sigma_i}^T + \xi_{\sigma_i} \end{cases} \quad (3.23)$$

For Model-I,II-BN

$$I_{\sigma_i(A)}(\sigma_i(A)) = \begin{cases} 1 & \text{if } \sigma_i(A) \geq U_{\sigma_i}^T \\ \exp\left\{\frac{\sigma_i(A) - (L_{\sigma_i}^T + \xi_{\sigma_i})}{U_{\sigma_i}^T - L_{\sigma_i}^T - \xi_{\sigma_i}}\right\} & \text{if } L_{\sigma_i}^T + \xi_{\sigma_i} \leq \sigma_i(A) \leq U_{\sigma_i}^T \\ 0 & \text{if } \sigma_i(A) \leq L_{\sigma_i}^T + \xi_{\sigma_i} \end{cases} \quad (3.24)$$

$$F_{\sigma_i(A)}(\sigma_i(A)) = \begin{cases} 0 & \text{if } \sigma_i(A) \leq L_{\sigma_i}^T + \varepsilon_{\sigma_i} \\ \frac{1}{2} + \frac{1}{2} \tanh\left\{\left(\sigma_i(A) - \frac{(U_{\sigma_i}^T + L_{\sigma_i}^T) + \varepsilon_{\sigma_i}}{2}\right)\tau_{\sigma_i}\right\} & \text{if } L_{\sigma_i}^T + \varepsilon_{\sigma_i} \leq \sigma_i(A) \leq U_{\sigma_i}^T \\ 1 & \text{if } \sigma_i(A) \geq U_{\sigma_i}^T \end{cases} \quad (3.25)$$

where  $\psi, \tau$  are non-zero parameters prescribed by the decision maker.

where  $0 < \varepsilon_{\sigma_i}, \xi_{\sigma_i} < (U_{\sigma_i}^T - L_{\sigma_i}^T)$

then according to Smarandache's definition of intersection of Neutrosophic sets and decision making criteria the neutrosophic optimization problem can be formulated as

**(P3.2)**

**Model-I- AL, BL, AN, BN**

$$\text{Maximize } (\alpha + \gamma - \beta) \quad (3.26)$$

such that

$$T_{WT(A)}(WT(A)) \geq \alpha; \quad (3.27)$$

$$T_{\sigma_i(A)}(\sigma_i(A)) \geq \alpha; \quad (3.28)$$

$$I_{WT(A)}(WT(A)) \geq \gamma; \quad (3.29)$$

$$I_{\sigma_i(A)}(\sigma_i(A)) \geq \gamma; \quad (3.30)$$

$$F_{WT(A)}(WT(A)) \leq \beta; \quad (3.31)$$

$$F_{\sigma_i(A)}(\sigma_i(A)) \leq \beta \quad (3.32)$$

$$\sigma_i(x) \leq [\sigma_i]; \quad (3.33)$$

$$\alpha + \beta + \gamma \leq 3; \alpha \geq \beta; \alpha \geq \gamma; \quad (3.34)$$

$$\alpha, \beta, \gamma \in [0, 1] \quad (3.35)$$

Where Model-I-AL,AN and Model-I-BL,BN stand for the neutrosophic optimization algorithm with indeterminacy membership function as of decreasing sense and as of increasing sense respectively.

But in real life problem decision maker needs to minimize indeterminacy membership function. So neutrosophic optimization problem also can be formulated as

**(P3.3)**

**Model-II-AL,AN,BL,BN**

$$\text{Maximize } (\alpha - \beta - \gamma) \quad (3.36)$$

such that

$$T_{WT(A)}(WT(A)) \geq \alpha; \quad (3.37)$$

$$T_{\sigma_i(A)}(\sigma_i(A)) \geq \alpha; \quad (3.38)$$

$$I_{WT(A)}(WT(A)) \leq \gamma; \quad (3.39)$$

$$I_{\sigma_i(A)}(\sigma_i(A)) \leq \gamma; \quad (3.40)$$

$$F_{WT(A)}(WT(A)) \leq \beta; \quad (3.41)$$

$$F_{\sigma_i(A)}(\sigma_i(A)) \leq \beta \quad (3.42)$$

$$\sigma_i(x) \leq [\sigma_i]; \quad (3.43)$$

$$\alpha + \beta + \gamma \leq 3; \alpha \geq \beta; \alpha \geq \gamma; \quad (3.44)$$

$$\alpha, \beta, \gamma \in [0, 1]$$

Where Model-II-AL,AN and Model-II-BL,BN stand for the neutrosophic optimization algorithm with indeterminacy membership function considered as of decreasing sense and as of increasing sense respectively.

Now the above problem can be simplified to following crisp linear programming problem, whenever linear membership are considered, as

**(P3.4)**

**Model-I-AL**



$$\text{Maximize } (\alpha - \beta + \gamma) \quad (3.45)$$

Such that

$$WT(A) + \alpha \left( U_{WT(A)}^T - L_{WT(A)}^T \right) \leq U_{WT(A)}^T; \quad (3.46)$$

$$WT(A) + \gamma \xi_{WT(A)} \leq L_{WT(A)}^T + \xi_{WT(A)}; \quad (3.47)$$

$$WT(A) - \beta \left( U_{WT(A)}^T - L_{WT(A)}^T - \varepsilon_{WT(A)} \right) \leq L_{WT(A)}^T + \varepsilon_{WT(A)}; \quad (3.48)$$

$$\sigma_T(A) + \alpha \left( U_{\sigma_T(A)}^T - L_{\sigma_T(A)}^T \right) \leq U_{\sigma_T(A)}^T; \quad (3.49)$$

$$\sigma_T(A) + \gamma \xi_{\sigma_T(A)} \leq L_{\sigma_T(A)}^T + \xi_{\sigma_T(A)}; \quad (3.50)$$

$$\sigma_T(A) - \beta \left( U_{\sigma_T(A)}^T - L_{\sigma_T(A)}^T - \varepsilon_{\sigma_T(A)} \right) \leq L_{\sigma_T(A)}^T + \varepsilon_{\sigma_T(A)}; \quad (3.51)$$

$$\sigma_C(A) + \alpha \left( U_{\sigma_C(A)}^T - L_{\sigma_C(A)}^T \right) \leq U_{\sigma_C(A)}^T; \quad (3.52)$$

$$\sigma_C(A) + \gamma \xi_{\sigma_C(A)} \leq U_{\sigma_C(A)}^T + \xi_{\sigma_C(A)}; \quad (3.53)$$

$$\alpha + \beta + \gamma \leq 3; \quad (3.54)$$

$$\alpha \geq \beta; \alpha \geq \gamma; \quad (3.55)$$

$$\alpha, \beta, \gamma \in [0, 1] \quad (3.56)$$

**(P3.5)**

**Model-I-BL**

$$\text{Maximize } (\alpha - \beta + \gamma) \quad (3.57)$$

Such that

$$WT(A) + \alpha \left( U_{WT(A)}^T - L_{WT(A)}^T \right) \leq U_{WT(A)}^T; \quad (3.58)$$

$$WT(A) - \gamma \left( U_{WT(A)}^T - L_{WT(A)}^T - \xi_{WT(A)} \right) \geq L_{WT(A)}^T + \xi_{WT(A)}; \quad (3.59)$$

$$WT(A) - \beta \left( U_{WT(A)}^T - L_{WT(A)}^T - \varepsilon_{WT(A)} \right) \leq L_{WT(A)}^T + \varepsilon_{WT(A)}; \quad (3.60)$$

$$\sigma_T(A) + \alpha \left( U_{\sigma_T(A)}^T - L_{\sigma_T(A)}^T \right) \leq U_{\sigma_T(A)}^T; \quad (3.61)$$

$$\sigma_T(A) - \gamma \left( U_{\sigma_T(A)}^T - L_{\sigma_T(A)}^T - \xi_{\sigma_T(A)} \right) \geq L_{\sigma_T(A)}^T + \xi_{\sigma_T(A)}; \quad (3.62)$$

$$\sigma_T(A) - \beta \left( U_{\sigma_T(A)}^T - L_{\sigma_T(A)}^T - \varepsilon_{\sigma_T(A)} \right) \leq L_{\sigma_T(A)}^T + \varepsilon_{\sigma_T(A)}; \quad (3.63)$$

$$\sigma_C(A) + \alpha \left( U_{\sigma_C(A)}^T - L_{\sigma_C(A)}^T \right) \leq U_{\sigma_C(A)}^T; \quad (3.64)$$

$$\sigma_C(A) - \gamma \left( U_{\sigma_C(A)}^T - L_{\sigma_C(A)}^T - \xi_{\sigma_C(A)} \right) \geq L_{\sigma_C(A)}^T + \xi_{\sigma_C(A)}; \quad (3.65)$$

$$\alpha + \beta + \gamma \leq 3; \quad (3.66)$$

$$\alpha \geq \beta; \alpha \geq \gamma; \quad (3.67)$$

$$\alpha, \beta, \gamma \in [0, 1] \quad (3.68)$$

and crisp linear programming problem like Model-I-A whenever non-linear membership function is considered as

**(P3.6)**

**Model-I-AN**

$$\text{Maximize } (\theta + \kappa - \eta) \quad (3.69)$$

such that

$$WT(A) + \theta \frac{\left( U_{WT(A)}^T - L_{WT(A)}^T \right)}{\psi} \leq U_{WT(A)}^T; \quad (3.70)$$

$$WT(A) + \frac{\eta}{\tau_{WT(A)}} \leq \frac{U_{WT(A)}^T + L_{WT(A)}^T + \varepsilon_{WT(A)}}{2}; \quad (3.71)$$

$$WT(A) + \kappa \xi_{WT(A)} \leq L_{WT(A)}^T + \xi_{WT(A)}; \quad (3.72)$$

$$\sigma_i(A) + \theta \frac{\left( U_{\sigma_i}^T - L_{\sigma_i}^T \right)}{\psi} \leq U_{\sigma_i}^T; \quad (3.73)$$

$$\sigma_i(A) + \kappa \xi_{\sigma_i(A)} \leq L_{\sigma_i}^T + \xi_{\sigma_i(A)}; \quad (3.74)$$

$$\sigma_i(A) + \frac{\eta}{\tau_{\sigma_i(A)}} \leq \frac{U_{\sigma_i}^T + L_{\sigma_i}^T + \varepsilon_{\sigma_i(A)}}{2}; \quad (3.75)$$

$$\theta + \kappa - \eta \leq 3; \quad (3.76)$$

$$\theta \geq \kappa; \theta \geq \eta; \quad (3.77)$$

$$\theta, \kappa, \eta \in [0, 1] \quad (3.78)$$

$$\text{Where } \theta = -\ln(1 - \alpha); \quad (3.79)$$

$$\psi = 4; \quad (3.80)$$

$$\tau_{WT(A)} = \frac{6}{\left( U_{WT(A)}^F - L_{WT(A)}^F \right)}; \quad (3.81)$$

$$\kappa = \ln \gamma; \quad (3.82)$$

$$\eta = -\tanh^{-1}(2\beta - 1). \quad (3.83)$$

$$\text{and } \tau_{\sigma_i(A)} = \frac{6}{\left(U_{\sigma_i(A)}^F - L_{\sigma_i(A)}^F\right)}; \quad (3.84)$$

**(P3.7)**

### Model-I-BN

$$\text{Maximize } (\theta + \kappa - \eta) \quad (3.85)$$

such that

$$WT(A) + \theta \frac{\left(U_{WT(A)}^T - L_{WT(A)}^T\right)}{\psi} \leq U_{WT(A)}^T; \quad (3.86)$$

$$WT(A) + \frac{\eta}{\tau_{WT(A)}} \leq \frac{U_{WT(A)}^T + L_{WT(A)}^T + \varepsilon_{WT(A)}}{2}; \quad (3.87)$$

$$WT(A) - \kappa \left( U_{WT(A)}^T - L_{WT(A)}^T - \xi_{WT(A)} \right) \geq L_{WT(A)}^T + \xi_{WT(A)}; \quad (3.88)$$

$$\sigma_i(A) + \theta \frac{\left(U_{\sigma_i}^T - L_{\sigma_i}^T\right)}{\psi} \leq U_{\sigma_i}^T; \quad (3.89)$$

$$\sigma_i(A) - \kappa \left( U_{\sigma_i}^T - L_{\sigma_i}^T - \xi_{\sigma_i(A)} \right) \geq L_{\sigma_i}^T + \xi_{\sigma_i(A)}; \quad (3.90)$$

$$\sigma_i(A) + \frac{\eta}{\tau_{\sigma_i(A)}} \leq \frac{L_{\sigma_i}^T + U_{\sigma_i}^T + \varepsilon_{\sigma_i(A)}}{2}; \quad (3.91)$$

$$\theta + \kappa - \eta \leq 3; \quad (3.92)$$

$$\theta \geq \kappa; \theta \geq \eta; \quad (3.93)$$

$$\theta, \kappa, \eta \in [0, 1] \quad (3.94)$$

$$\text{Where } \theta = -\ln(1 - \alpha); \quad (3.95)$$

$$\psi = 4; \quad (3.96)$$

$$\tau_{WT(A)} = \frac{6}{\left(U_{WT(A)}^F - L_{WT(A)}^F\right)}; \quad (3.97)$$

$$\kappa = \ln \gamma; \quad (3.98)$$

$$\eta = -\tanh^{-1}(2\beta - 1). \quad (3.99)$$

$$\text{and } \tau_{\sigma_i(A)} = \frac{6}{\left( U_{\sigma_i(A)}^F - L_{\sigma_i(A)}^F \right)}; \quad (3.100)$$

Using linear and nonlinear truth, indeterminacy, and falsity membership function Model-II can be simplified as

**(P3.8)**

**Model-II-AL**

$$\text{Maximize } (\alpha - \beta - \gamma) \quad (3.101)$$

Such that

$$WT(A) + \alpha \left( U_{WT(A)}^T - L_{WT(A)}^T \right) \leq U_{WT(A)}^T; \quad (3.102)$$

$$WT(A) + \gamma \xi_{WT(A)} \geq L_{WT(A)}^T + \xi_{WT(A)}; \quad (3.103)$$

$$WT(A) - \beta \left( U_{WT(A)}^T - L_{WT(A)}^T - \varepsilon_{WT(A)} \right) \leq L_{WT(A)}^T + \varepsilon_{WT(A)}; \quad (3.104)$$

$$\sigma_T(A) + \alpha \left( U_{\sigma_T(A)}^T - L_{\sigma_T(A)}^T \right) \leq U_{\sigma_T(A)}^T; \quad (3.105)$$

$$\sigma_T(A) + \gamma \xi_{\sigma_T(A)} \geq L_{\sigma_T(A)}^T + \xi_{\sigma_T(A)}; \quad (3.106)$$

$$\sigma_T(A) - \beta \left( U_{\sigma_T(A)}^T - L_{\sigma_T(A)}^T - \varepsilon_{\sigma_T(A)} \right) \leq L_{\sigma_T(A)}^T + \varepsilon_{\sigma_T(A)}; \quad (3.107)$$

$$\sigma_C(A) + \alpha \left( U_{\sigma_C(A)}^T - L_{\sigma_C(A)}^T \right) \leq U_{\sigma_C(A)}^T; \quad (3.108)$$

$$\sigma_C(A) + \gamma \xi_{\sigma_C(A)} \geq U_{\sigma_C(A)}^T + \xi_{\sigma_C(A)}; \quad (3.109)$$

$$\alpha + \beta + \gamma \leq 3; \quad (3.110)$$

$$\alpha \geq \beta; \alpha \geq \gamma; \quad (3.111)$$

$$\alpha, \beta, \gamma \in [0, 1] \quad (3.112)$$

**(P3.9)**

**Model-II-BL**

$$\text{Maximize } (\alpha - \beta - \gamma) \quad (3.113)$$

Such that

$$WT(A) + \alpha \left( U_{WT(A)}^T - L_{WT(A)}^T \right) \leq U_{WT(A)}^T; \quad (3.114)$$

$$WT(A) - \gamma \left( U_{WT(A)}^T - L_{WT(A)}^T - \xi_{WT(A)} \right) \leq L_{WT(A)}^T + \xi_{WT(A)}; \quad (3.115)$$

$$WT(A) - \beta \left( U_{WT(A)}^T - L_{WT(A)}^T - \varepsilon_{WT(A)} \right) \leq L_{WT(A)}^T + \varepsilon_{WT(A)}; \quad (3.116)$$

$$\sigma_T(A) + \alpha \left( U_{\sigma_T(A)}^T - L_{\sigma_T(A)}^T \right) \leq U_{\sigma_T(A)}^T; \quad (3.117)$$

$$\sigma_T(A) - \gamma \left( U_{\sigma_T(A)}^T - L_{\sigma_T(A)}^T - \xi_{\sigma_T(A)} \right) \leq L_{\sigma_T(A)}^T + \xi_{\sigma_T(A)}; \quad (3.118)$$

$$\sigma_T(A) - \beta \left( U_{\sigma_T(A)}^T - L_{\sigma_T(A)}^T - \varepsilon_{\sigma_T(A)} \right) \leq L_{\sigma_T(A)}^T + \varepsilon_{\sigma_T(A)}; \quad (3.119)$$

$$\sigma_C(A) + \alpha \left( U_{\sigma_C(A)}^T - L_{\sigma_C(A)}^T \right) \leq U_{\sigma_C(A)}^T; \quad (3.120)$$

$$\sigma_C(A) - \gamma \left( U_{\sigma_C(A)}^T - L_{\sigma_C(A)}^T - \xi_{\sigma_C(A)} \right) \leq L_{\sigma_C(A)}^T + \xi_{\sigma_C(A)}; \quad (3.121)$$

$$\alpha + \beta + \gamma \leq 3; \quad (3.122)$$

$$\alpha \geq \beta; \alpha \geq \gamma; \quad (3.123)$$

$$\alpha, \beta, \gamma \in [0, 1] \quad (3.124)$$

**(P3.10)**

### Model-II-AN

$$\text{Maximize } (\theta - \kappa - \eta) \quad (3.125)$$

Such that

$$WT(A) + \theta \frac{\left( U_{WT(A)}^T - L_{WT(A)}^T \right)}{\psi} \leq U_{WT(A)}^T; \quad (3.126)$$

$$WT(A) + \frac{\eta}{\tau_{WT(A)}} \leq \frac{U_{WT(A)}^T + L_{WT(A)}^T + \varepsilon_{WT(A)}}{2}; \quad (3.127)$$

$$WT(A) + \kappa \xi_{WT(A)} \geq L_{WT(A)}^T + \xi_{WT(A)}; \quad (3.128)$$

$$\sigma_i(A) + \theta \frac{\left( U_{\sigma_i}^T - L_{\sigma_i}^T \right)}{\psi} \leq U_{\sigma_i}^T; \quad (3.129)$$

$$\sigma_i(A) + \kappa \xi_{\sigma_i(A)} \geq L_{\sigma_i}^T + \xi_{\sigma_i(A)}; \quad (3.130)$$

$$\sigma_i(A) + \frac{\eta}{\tau_{\sigma_i(A)}} \leq \frac{U_{\sigma_i}^T + L_{\sigma_i}^T + \varepsilon_{\sigma_i(A)}}{2}; \quad (3.131)$$

$$\theta + \kappa - \eta \leq 3; \quad (3.132)$$

$$\theta \geq \kappa; \theta \geq \eta; \quad (3.133)$$

$$\theta, \kappa, \eta \in [0, 1] \quad (3.134)$$

$$\text{Where } \theta = -\ln(1 - \alpha); \quad (3.135)$$

$$\psi = 4; \quad (3.136)$$

$$\tau_{WT(A)} = \frac{6}{\left( U_{WT(A)}^F - L_{WT(A)}^F \right)}; \quad (3.137)$$

$$\kappa = \ln \gamma; \quad (3.138)$$

$$\eta = -\tanh^{-1}(2\beta - 1). \quad (3.139)$$

$$\text{and } \tau_{\sigma_i(A)} = \frac{6}{\left( U_{\sigma_i(A)}^F - L_{\sigma_i(A)}^F \right)}; \quad (3.140)$$

**(P3.11)**

**Model-II-BN**

$$\text{Maximize } (\theta - \kappa - \eta) \quad (3.141)$$

such that

$$WT(A) + \theta \frac{\left( U_{WT(A)}^T - L_{WT(A)}^T \right)}{\psi} \leq U_{WT(A)}^T; \quad (3.142)$$

$$WT(A) + \frac{\eta}{\tau_{WT(A)}} \leq \frac{U_{WT(A)}^T + L_{WT(A)}^T + \varepsilon_{WT(A)}}{2}; \quad (3.143)$$

$$WT(A) - \kappa \left( U_{WT(A)}^T - L_{WT(A)}^T - \xi_{WT(A)} \right) \leq L_{WT(A)}^T + \xi_{WT(A)}; \quad (3.144)$$

$$\sigma_i(A) + \theta \frac{\left( U_{\sigma_i}^T - L_{\sigma_i}^T \right)}{\psi} \leq U_{\sigma_i}^T; \quad (3.145)$$

$$\sigma_i(A) - \kappa \left( U_{\sigma_i}^T - L_{\sigma_i}^T - \xi_{\sigma_i(A)} \right) \leq L_{\sigma_i}^T + \xi_{\sigma_i(A)}; \quad (3.146)$$

$$\sigma_i(A) + \frac{\eta}{\tau_{\sigma_i(A)}} \leq \frac{L_{\sigma_i}^T + U_{\sigma_i}^T + \varepsilon_{\sigma_i(A)}}{2}; \quad (3.147)$$

$$\theta + \kappa - \eta \leq 3; \quad (3.148)$$

$$\theta \geq \kappa; \theta \geq \eta; \quad (3.149)$$

$$\theta, \kappa, \eta \in [0,1] \quad (3.150)$$

$$\text{Where } \theta = -\ln(1-\alpha); \quad (3.151)$$

$$\psi = 4; \quad (3.152)$$

$$\tau_{WT(A)} = \frac{6}{\left(U_{WT(A)}^F - L_{WT(A)}^F\right)}; \quad (3.153)$$

$$\kappa = \ln \gamma; \quad (3.154)$$

$$\eta = -\tanh^{-1}(2\beta - 1). \quad (3.155)$$

$$\text{and } \tau_{\sigma_i(A)} = \frac{6}{\left(U_{\sigma_i(A)}^F - L_{\sigma_i(A)}^F\right)}; \quad (3.156)$$

All these crisp nonlinear programming problem can be solved by appropriate mathematical algorithm.

### 3.3 Numerical Solution of Two Bar Truss Design using Single Objective NSO Technique

A well-known two-bar planar truss structure (Fig.-3.1) is considered and the detail formulation is given in appendix. The design objective is to minimize weight of the structural  $WT(A_1, A_2, y_B)$  of a statistically loaded two-bar truss subjected to stress  $\sigma_i(A_1, A_2, y_B)$  constraints on each of the truss members  $i = 1, 2$ .

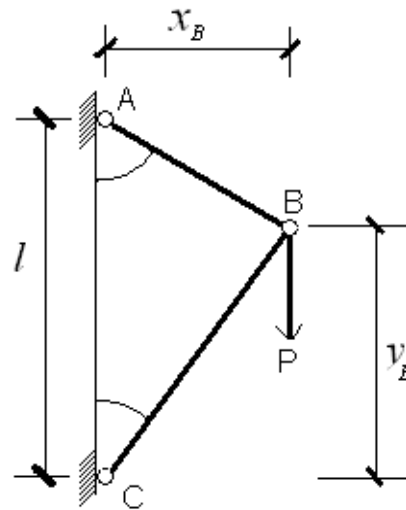

**Fig.-3.1** Design of the Two-Bar Truss(<http://www.sciencedirect.com>, accessed on 17 June 2017)

The single-objective optimization problem can be stated as follows

(P3.12)

$$\text{Minimize } WT(A_1, A_2, y_B) = \rho \left( A_1 \sqrt{x_B^2 + (l - y_B)^2} + A_2 \sqrt{x_B^2 + y_B^2} \right) \quad (3.157)$$

Such that

$$\sigma_{AB}(A_1, A_2, y_B) \equiv \frac{P \sqrt{x_B^2 + (l - y_B)^2}}{l A_1} \leq [\sigma_{AB}^T]; \quad (3.158)$$

$$\sigma_{BC}(A_1, A_2, y_B) \equiv \frac{P \sqrt{x_B^2 + y_B^2}}{l A_2} \leq [\sigma_{BC}^C]; \quad (3.159)$$

$$0.5 \leq y_B \leq 1.5 \quad (3.160)$$

$$A_1 > 0, A_2 > 0; \quad (3.161)$$

where  $P$  = nodal load ;  $\rho$  = volume density ;  $l$  = length of  $AC$  ;  $x_B$  = perpendicular distance from  $AC$  to point  $B$  .  $A_1$  = Cross section of bar-  $AB$  ;  $A_2$  = Cross section of bar-  $BC$  .  $[\sigma_T]$  = maximum allowable tensile stress,  $[\sigma_C]$  = maximum allowable compressive stress and  $y_B$  =  $y$ -co-ordinate of node  $B$  . Input data are given in Table 3.1.

**Table 3.1 Input Data for Crisp Model (P3.8)**

Applied load $P$ (KN)	Volume density $\rho$ (KN/m <sup>3</sup> )	Length 1 (m)	Maximum allowable tensile stress $[\sigma_T]$ (Mpa)	Maximum allowable compressive stress $[\sigma_C]$ (Mpa)	Distance of $x_B$ from $AC$ (m)
100	7.7	2	130 with fuzzy region 20	90 with fuzzy region 10	1

Solution: According to step 2 of 1.29, we find upper and lower bound of membership function of objective function as  $U_{WT(A)}^T, U_{WT(A)}^I, U_{WT(A)}^F$  and  $U_{WT(A)}^T, U_{WT(A)}^I, U_{WT(A)}^F$  where  $U_{WT(A)}^T = 14.23932 = U_{WT(A)}^F, L_{WT(A)}^T = 12.57667 = L_{WT(A)}^I, L_{WT(A)}^F = 12.57667 + \varepsilon_{WT(A)}$  with  $0 < \varepsilon_{WT(A)} < 1.66265$ ; and  $U_{WT(A)}^I = L_{WT(A)}^T + \xi_{WT(A)}$  where  $0 < \xi_{WT(A)} < 1.66265$



Now using the bounds we calculate the membership functions for objective as follows

$$T_{WT(A_1, A_2, y_B)}(WT(A_1, A_2, y_B)) = \begin{cases} 1 & \text{if } WT(A_1, A_2, y_B) \leq 12.57667 \\ \left( \frac{14.23932 - WT(A_1, A_2, y_B)}{1.66265} \right) & \text{if } 12.57667 \leq WT(A_1, A_2, y_B) \leq 14.23932 \\ 0 & \text{if } WT(A_1, A_2, y_B) \geq 14.23932 \end{cases} \quad (3.162)$$

For Model-I,II,AL

$$I_{WT(A_1, A_2, y_B)}(WT(A_1, A_2, y_B)) = \begin{cases} 1 & \text{if } WT(A_1, A_2, y_B) \leq 12.57667 \\ \left( \frac{(12.57667 + \xi_{WT(A)}) - WT(A_1, A_2, y_B)}{\xi_{WT(A)}} \right) & \text{if } 12.57667 \leq WT(A_1, A_2, y_B) \leq 12.57667 + \xi_{WT(A)} \\ 0 & \text{if } WT(A_1, A_2, y_B) \geq 12.57667 + \xi_{WT(A)} \end{cases} \quad (3.163)$$

For Model-I,II,BL

$$I_{WT(A_1, A_2, y_B)}(WT(A_1, A_2, y_B)) = \begin{cases} 1 & \text{if } WT(A_1, A_2, y_B) \geq 14.23932 \\ \left( \frac{WT(A_1, A_2, y_B) - (12.57667 + \xi_{WT(A)})}{1.66265 - \xi_{WT(A)}} \right) & \text{if } 12.57667 + \xi_{WT(A)} \leq WT(A_1, A_2, y_B) \leq 14.23932 \\ 0 & \text{if } WT(A_1, A_2, y_B) \leq 12.57667 + \xi_{WT(A)} \end{cases} \quad (3.164)$$

$$F_{WT(A_1, A_2, y_B)}(WT(A_1, A_2, y_B)) = \begin{cases} 0 & \text{if } WT(A_1, A_2, y_B) \leq 12.57667 + \varepsilon_{WT(A)} \\ \left( \frac{WT(A_1, A_2, y_B) - 12.57667 - \varepsilon_{WT(A)}}{1.66265 - \varepsilon_{WT(A)}} \right) & \text{if } 12.57667 + \varepsilon_{WT(A)} \leq WT(A_1, A_2, y_B) \leq 14.23932 \\ 1 & \text{if } WT(A_1, A_2, y_B) \geq 14.23932 \end{cases} \quad (3.165)$$

Similarly the membership functions for tensile stress are

$$T_{\sigma_T(A_1, A_2, y_B)}(\sigma_T(A_1, A_2, y_B)) = \begin{cases} 1 & \text{if } \sigma_T(A_1, A_2, y_B) \leq 130 \\ \left( \frac{150 - \sigma_T(A_1, A_2, y_B)}{20} \right) & \text{if } 130 \leq \sigma_T(A_1, A_2, y_B) \leq 150 \\ 0 & \text{if } \sigma_T(A_1, A_2, y_B) \geq 150 \end{cases} \quad (3.166)$$

For Model-I,II,AL

$$I_{\sigma_T(A_1, A_2, y_B)}(\sigma_T(A_1, A_2, y_B)) = \begin{cases} 1 & \text{if } \sigma_T(A_1, A_2, y_B) \leq 130 \\ \left( \frac{(130 + \xi_{\sigma_T}) - \sigma_T(A_1, A_2, y_B)}{\xi_{\sigma_T}} \right) & \text{if } 130 \leq \sigma_T(A_1, A_2, y_B) \leq 130 + \xi_{\sigma_T} \\ 0 & \text{if } \sigma_T(A_1, A_2, y_B) \geq 130 + \xi_{\sigma_T} \end{cases}$$

(3.167)

For Model-I,II,BL

$$I_{\sigma_T(A_1, A_2, y_B)}(\sigma_T(A_1, A_2, y_B)) = \begin{cases} 1 & \text{if } \sigma_T(A_1, A_2, y_B) \geq 150 \\ \left( \frac{\sigma_T(A_1, A_2, y_B) - (130 + \xi_{\sigma_T})}{20 - \xi_{\sigma_T}} \right) & \text{if } 130 + \xi_{\sigma_T} \leq \sigma_T(A_1, A_2, y_B) \leq 150 \\ 0 & \text{if } \sigma_T(A_1, A_2, y_B) \leq 130 + \xi_{\sigma_T} \end{cases} \quad (3.168)$$

$$F_{\sigma_T(A_1, A_2, y_B)}(\sigma_T(A_1, A_2, y_B)) = \begin{cases} 0 & \text{if } \sigma_T(A_1, A_2, y_B) \leq 130 + \varepsilon_{\sigma_T} \\ \left( \frac{\sigma_T(A_1, A_2, y_B) - 130 - \varepsilon_{\sigma_T}}{20 - \varepsilon_{\sigma_T}} \right) & \text{if } 130 + \varepsilon_{\sigma_T} \leq \sigma_T(A_1, A_2, y_B) \leq 150 \\ 1 & \text{if } \sigma_T(A_1, A_2, y_B) \geq 150 \end{cases} \quad (3.169)$$

where  $0 < \varepsilon_{\sigma_T}, \xi_{\sigma_T} < 20$

and the membership functions for compressive stress constraint are

$$T_{\sigma_C(A_1, A_2, y_B)}(\sigma_C(A_1, A_2, y_B)) = \begin{cases} 1 & \text{if } \sigma_C(A_1, A_2, y_B) \leq 90 \\ \left( \frac{100 - \sigma_C(A_1, A_2, y_B)}{10} \right) & \text{if } 90 \leq \sigma_C(A_1, A_2, y_B) \leq 100 \\ 0 & \text{if } \sigma_C(A_1, A_2, y_B) \geq 100 \end{cases} \quad (3.170)$$

For Model-I,II,AL

$$I_{\sigma_C(A_1, A_2, y_B)}(\sigma_C(A_1, A_2, y_B)) = \begin{cases} 1 & \text{if } \sigma_C(A_1, A_2, y_B) \leq 90 \\ \left( \frac{(90 + \xi_{\sigma_C}) - \sigma_C(A_1, A_2, y_B)}{\xi_{\sigma_C}} \right) & \text{if } 90 \leq \sigma_C(A_1, A_2, y_B) \leq 90 + \xi_{\sigma_C} \\ 0 & \text{if } \sigma_C(A_1, A_2, y_B) \geq 90 + \xi_{\sigma_C} \end{cases} \quad (3.171)$$

For Model-I,II,BL

$$I_{\sigma_C(A_1, A_2, y_B)}(\sigma_C(A_1, A_2, y_B)) = \begin{cases} 1 & \text{if } \sigma_C(A_1, A_2, y_B) \geq 100 \\ \left( \frac{\sigma_C(A_1, A_2, y_B) - (90 + \xi_{\sigma_C})}{10 - \xi_{\sigma_C}} \right) & \text{if } 90 + \xi_{\sigma_C} \leq \sigma_C(A_1, A_2, y_B) \leq 100 \\ 0 & \text{if } \sigma_C(A_1, A_2, y_B) \leq 90 + \xi_{\sigma_C} \end{cases} \quad (3.172)$$

$$F_{\sigma_C(A_1, A_2, y_B)}(\sigma_C(A_1, A_2, y_B)) = \begin{cases} 0 & \text{if } \sigma_C(A_1, A_2, y_B) \leq 90 + \varepsilon_{\sigma_C} \\ \left( \frac{\sigma_C(A_1, A_2, y_B) - 90 - \varepsilon_{\sigma_C}}{10 - \varepsilon_{\sigma_C}} \right) & \text{if } 90 + \varepsilon_{\sigma_C} \leq \sigma_C(A_1, A_2, y_B) \leq 100 \\ 1 & \text{if } \sigma_C(A_1, A_2, y_B) \geq 100 \end{cases} \quad (3.173)$$

where  $0 < \varepsilon_{\sigma_C}, \xi_{\sigma_C} < 10$

Again the nonlinear truth, indeterminacy and falsity membership functions for objectives and constraints can be formulated as

$$T_{WT(A_1, A_2, y_B)}(WT(A_1, A_2, y_B)) = \begin{cases} 1 & \text{if } WT(A_1, A_2, y_B) \leq 12.57667 \\ 1 - \exp\left\{-4\left(\frac{14.23932 - WT(A_1, A_2, y_B)}{1.66265}\right)\right\} & \text{if } 12.57667 \leq WT(A_1, A_2, y_B) \leq 14.23932 \\ 0 & \text{if } WT(A_1, A_2, y_B) \geq 14.23932 \end{cases} \quad (3.174)$$

For Model-I,II,AN

$$I_{WT(A_1, A_2, y_B)}(WT(A_1, A_2, y_B)) = \begin{cases} 1 & \text{if } WT(A_1, A_2, y_B) \leq 12.57667 \\ \exp\left\{\frac{(12.57667 + \xi_{WT}) - WT(A_1, A_2, y_B)}{\xi_{WT}}\right\} & \text{if } 12.57667 \leq WT(A_1, A_2, y_B) \leq 12.57667 + \xi_{WT} \\ 0 & \text{if } WT(A_1, A_2, y_B) \geq 12.57667 + \xi_{WT} \end{cases} \quad (3.175)$$

For Model-I,II,BN

$$I_{WT(A_1, A_2, y_B)}(WT(A_1, A_2, y_B)) = \begin{cases} 1 & \text{if } WT(A_1, A_2, y_B) \geq 14.23932 \\ \exp\left\{\frac{WT(A_1, A_2, y_B) - (12.57667 + \xi_{WT})}{1.66265 - \xi_{WT}}\right\} & \text{if } 12.57667 + \xi_{WT} \leq WT(A_1, A_2, y_B) \leq 14.23932 \\ 0 & \text{if } WT(A_1, A_2, y_B) \leq 12.57667 + \xi_{WT} \end{cases} \quad (3.176)$$

$$F_{WT(A_1, A_2, y_B)}(WT(A_1, A_2, y_B)) = \begin{cases} 0 & \text{if } WT(A_1, A_2, y_B) \leq 12.57667 + \varepsilon_{WT} \\ \frac{1}{2} + \frac{1}{2} \tanh\left\{\left(\frac{WT(A_1, A_2, y_B) - (26.81599 + \varepsilon_{WT})}{2}\right) \frac{6}{1.66265 - \varepsilon_{WT}}\right\} & \text{if } 12.57667 + \varepsilon_{WT} \leq WT(A_1, A_2, y_B) \leq 14.23932 \\ 1 & \text{if } WT(A_1, A_2, y_B) \geq 14.23932 \end{cases} \quad (3.177)$$

Similarly the membership functions for tensile stress are

$$T_{\sigma_T(A_1, A_2, y_B)}(\sigma_T(A_1, A_2, y_B)) = \begin{cases} 1 & \text{if } \sigma_T(A_1, A_2, y_B) \leq 130 \\ 1 - \exp\left\{-4\left(\frac{150 - \sigma_T(A_1, A_2, y_B)}{20}\right)\right\} & \text{if } 130 \leq \sigma_T(A_1, A_2, y_B) \leq 150 \\ 0 & \text{if } \sigma_T(A_1, A_2, y_B) \geq 150 \end{cases} \quad (3.178)$$

For Model-I,II,AN

$$I_{\sigma_T(A_1, A_2, y_B)}(\sigma_T(A_1, A_2, y_B)) = \begin{cases} 1 & \text{if } \sigma_T(A_1, A_2, y_B) \leq 130 \\ \exp\left\{\frac{(130 + \xi_{\sigma_T}) - \sigma_T(A_1, A_2, y_B)}{\xi_{\sigma_T}}\right\} & \text{if } 130 \leq \sigma_T(A_1, A_2, y_B) \leq 130 + \xi_{\sigma_T} \\ 0 & \text{if } \sigma_T(A_1, A_2, y_B) \geq 130 + \xi_{\sigma_T} \end{cases} \quad (3.179)$$

For Model-I,II,BN

$$I_{\sigma_T(A_1, A_2, y_B)}(\sigma_T(A_1, A_2, y_B)) = \begin{cases} 1 & \text{if } \sigma_T(A_1, A_2, y_B) \geq 150 \\ \exp\left\{\frac{\sigma_T(A_1, A_2, y_B) - (130 + \xi_{\sigma_T})}{20 - \xi_{\sigma_T}}\right\} & \text{if } 130 + \xi_{\sigma_T} \leq \sigma_T(A_1, A_2, y_B) \leq 150 \\ 0 & \text{if } \sigma_T(A_1, A_2, y_B) \leq 130 + \xi_{\sigma_T} \end{cases} \quad (3.180)$$

$$F_{\sigma_T(A_1, A_2, y_B)}(\sigma_T(A_1, A_2, y_B)) = \begin{cases} 0 & \text{if } \sigma_T(A_1, A_2, y_B) \leq 130 + \varepsilon_{\sigma_T} \\ \frac{1}{2} + \frac{1}{2} \tanh\left\{\left(\sigma_T(A_1, A_2, y_B) - \left(\frac{280 + \varepsilon_{\sigma_T}}{2}\right)\right) \frac{6}{20 - \varepsilon_{\sigma_T}}\right\} & \text{if } 130 + \varepsilon_{\sigma_T} \leq \sigma_T(A_1, A_2, y_B) \leq 150 \\ 1 & \text{if } \sigma_T(A_1, A_2, y_B) \geq 150 \end{cases} \quad (3.181)$$

where  $0 < \varepsilon_{\sigma_T}, \xi_{\sigma_T} < 20$

and the membership functions for compressive stress constraint are

$$T_{\sigma_C(A_1, A_2, y_B)}(\sigma_C(A_1, A_2, y_B)) = \begin{cases} 1 & \text{if } \sigma_C(A_1, A_2, y_B) \leq 90 \\ 1 - \exp\left\{-4\left(\frac{100 - \sigma_C(A_1, A_2, y_B)}{10}\right)\right\} & \text{if } 90 \leq \sigma_C(A_1, A_2, y_B) \leq 100 \\ 0 & \text{if } \sigma_C(A_1, A_2, y_B) \geq 100 \end{cases} \quad (3.182)$$

For Model-I,II,AN

$$I_{\sigma_C(A_1, A_2, y_B)}(\sigma_C(A_1, A_2, y_B)) = \begin{cases} 1 & \text{if } \sigma_C(A_1, A_2, y_B) \leq 90 \\ \exp\left\{\frac{(90 + \xi_{\sigma_C}) - \sigma_C(A_1, A_2, y_B)}{\xi_{\sigma_C}}\right\} & \text{if } 90 \leq \sigma_C(A_1, A_2, y_B) \leq 90 + \xi_{\sigma_C} \\ 0 & \text{if } \sigma_C(A_1, A_2, y_B) \geq 90 + \xi_{\sigma_C} \end{cases} \quad (3.183)$$

For Model-I,II,BN

$$I_{\sigma_C(A_1, A_2, y_B)}(\sigma_C(A_1, A_2, y_B)) = \begin{cases} 1 & \text{if } \sigma_C(A_1, A_2, y_B) \geq 100 \\ \exp\left\{\frac{\sigma_C(A_1, A_2, y_B) - (90 + \xi_{\sigma_C})}{10 - \xi_{\sigma_C}}\right\} & \text{if } 90 + \xi_{\sigma_C} \leq \sigma_C(A_1, A_2, y_B) \leq 100 \\ 0 & \text{if } \sigma_C(A_1, A_2, y_B) \leq 90 + \xi_{\sigma_C} \end{cases} \quad (3.184)$$

$$F_{\sigma_C(A_1, A_2, y_B)}(\sigma_C(A_1, A_2, y_B)) = \begin{cases} 0 & \text{if } \sigma_C(A_1, A_2, y_B) \leq 90 + \varepsilon_{\sigma_C} \\ \frac{1}{2} + \frac{1}{2} \tanh\left\{\left(\sigma_C(A_1, A_2, y_B) - \left(\frac{190 + \varepsilon_{\sigma_C}}{2}\right)\right) \frac{6}{10 - \varepsilon_{\sigma_C}}\right\} & \text{if } 90 + \varepsilon_{\sigma_C} \leq \sigma_C(A_1, A_2, y_B) \leq 100 \\ 1 & \text{if } \sigma_C(A_1, A_2, y_B) \geq 100 \end{cases} \quad (3.185)$$

where  $0 < \varepsilon_{\sigma_C}, \xi_{\sigma_C} < 10$

Now , using above mentioned truth, indeterminacy and falsity linear and nonlinear membership function NLP (P3.12) can be solved for Model-I-AL,AN, Model-I-BL,BN, Model-II-AL,AN, Model-II-BL,BN by NSO technique for different values of  $\varepsilon_{WT}, \varepsilon_{\sigma_T}, \varepsilon_{\sigma_C}$  and  $\xi_{WT}, \xi_{\sigma_T}, \xi_{\sigma_C}$ . The optimum solution of SOSOP(P3.12) is given in Table 3.2 and Table 3.3 and the solution is compared with fuzzy and intuitionistic fuzzy problem.

**Table 3.2 Comparison of Optimal Solution of SOSOP (P3.12) for Model I based on Different Methods**

Methods	Model	$A_1$ ( $m^2$ )	$A_2$ ( $m^2$ )	$WT(A_1, A_2)$ (KN)	$y_B$ (m)
Fuzzy single-objective non-linear programming (FSONLP)	I-AL	.5883491	.7183381	<b>14.23932</b>	1.013955
	I-AN	.5883491	.7183381	<b>14.23932</b>	1.013955
Intuitionistic Fuzzy single-objective non-linear programming (FSONLP)	I-AL $\varepsilon_{WT} = 0.33253, \varepsilon_{\sigma_T} = 4, \varepsilon_{\sigma_C} = 2$	0.5482919	0.6692795	<b>13.19429</b>	0.8067448
	I-AN $\varepsilon_{WT} = 0.8, \varepsilon_{\sigma_T} = 16, \varepsilon_{\sigma_C} = 8$	0.6064095	0.6053373	<b>13.59182</b>	0.5211994
Neutrosophic optimization(NSO)	I-AL $\varepsilon_{WT} = 0.33253, \varepsilon_{\sigma_T} = 4, \varepsilon_{\sigma_C} = 2$ $\xi_{WT} = .498795, \xi_{\sigma_T} = 6, \xi_{\sigma_C} = 3$	.5954331	.7178116	<b>13.07546</b>	.818181

	I-BL $\xi_{WT} = .498795, \xi_{\sigma_T} = 6, \xi_{\sigma_C} = 3$ $\varepsilon_{WT} = 0.33253, \varepsilon_{\sigma_T} = 4, \varepsilon_{\sigma_C} = 2$	NO	FEASIBLE	<b>SOLUTION</b>	FOUND
	I-AN $\varepsilon_{WT} = 0.8, \varepsilon_{\sigma_T} = 16, \varepsilon_{\sigma_C} = 8$ $\xi_{WT} = 0.66506, \xi_{\sigma_T} = 8, \xi_{\sigma_C} = 4$	0.5451860	0.677883	<b>13.24173</b>	0.7900455
	I-BN $\varepsilon_{WT} = 0.8, \varepsilon_{\sigma_T} = 16, \varepsilon_{\sigma_C} = 8$ $\xi_{WT} = 0.66506, \xi_{\sigma_T} = 8, \xi_{\sigma_C} = 4$	NO	FEASIBLE	<b>SOLUTION</b>	FOUND

**Table 3.3 Comparison of Optimal Solution of SOSOP (P3.12) for Model II based on Different Method**

Methods	Model	$A_1$ ( $m^2$ )	$A_2$ ( $m^2$ )	$WT(A_1, A_2)$ ( $KN$ )	$y_B$ ( $m$ )
Fuzzy single-objective non-linear programming (FSONLP)	II-AL	.5954331	.7178116	<b>14.23932</b>	0.81818
	II-AN	1.317107	0.7174615	<b>13.82366</b>	1.399050
Intuitionistic Fuzzy single-objective non-linear programming (IFSONLP)	II-AL $\varepsilon_{WT} = 0.33253, \varepsilon_{\sigma_T} = 4, \varepsilon_{\sigma_C} = 2$	0.5954331	0.7178116	<b>13.50036</b>	0.8181818
	II-AN $\varepsilon_{WT} = 0.8, \varepsilon_{\sigma_T} = 16, \varepsilon_{\sigma_C} = 8$	1.107847	0.2557545	<b>13.78028</b>	0.5
Neutrosophic optimization(NSO)	II-AL $\varepsilon_{WT} = 0.33253, \varepsilon_{\sigma_T} = 4, \varepsilon_{\sigma_C} = 2$ $\xi_{WT} = .498795, \xi_{\sigma_T} = 6, \xi_{\sigma_C} = 3$	0.5954331	0.7178116	<b>13.13089</b>	.8181817
	II-BL $\xi_{WT} = .498795, \xi_{\sigma_T} = 6, \xi_{\sigma_C} = 3$ $\varepsilon_{WT} = 0.33253, \varepsilon_{\sigma_T} = 4, \varepsilon_{\sigma_C} = 2$	3.603750	3.603750	<b>12.90920</b>	1
	II-AN $\varepsilon_{WT} = 0.8, \varepsilon_{\sigma_T} = 16, \varepsilon_{\sigma_C} = 8$ $\xi_{WT} = 0.66506, \xi_{\sigma_T} = 8, \xi_{\sigma_C} = 4$	0.6494508	0.8336701	<b>13.78028</b>	0.5004718

	II-BN				
	$\varepsilon_{WT} = 0.8, \varepsilon_{\sigma_T} = 16, \varepsilon_{\sigma_C} = 8$	3.603750	4.043915	<b>13.07546</b>	0.5
	$\xi_{WT} = 0.66506, \xi_{\sigma_T} = 8, \xi_{\sigma_C} = 4$				

Here we get best solutions for the different tolerance  $\xi_{WT}, \xi_{\sigma_T}$  and  $\xi_{\sigma_C}$  for indeterminacy membership function of objective functions whenever indeterminacy is tried to be minimized (i.e in Model II) for this structural optimization problem. From Table 3.2 and Table 3.3, it is shown that NSO technique gives better optimal result in the perspective of Structural Optimization.

### 3.4 Conclusion

This work is done for illustration of NSO technique that using linear and nonlinear membership function how it can be utilized to solve a single objective-nonlinear structural problem. The concept of NSO technique allows one to define a degree of truth membership, which is not a complement of degree of falsity; rather, they are independent with degree of indeterminacy. The numerical illustration shows the superiority of NSO over FO and IFO. The results of this study may lead to the development of effective neutrosophic technique for solving other models in form of single objective nonlinear programming problem in other field of engineering .

# CHAPTER 4

---

## Multi-objective Neutrosophic Optimization Technique and its Application to Structural Design

---

In the field of civil engineering nonlinear structural design optimizations are of great of importance. So the description of structural geometry and mechanical properties like stiffness are required for a structural system. However the system description and system inputs may not be exact due to human errors or some unexpected situations. At this juncture fuzzy set theory provides a method which deal with ambiguous situations like vague parameters, non-exact objective and constraint. In structural engineering design problems, the input data and parameters are often fuzzy/imprecise with nonlinear characteristics that necessitate the development of fuzzy optimum structural design method. Fuzzy set (FS) theory has long been introduced to handle inexact and imprecise data by Zadeh [133], Later on Bellman and Zadeh [10] used the FS theory to the decision making problem. The FS theory also found application in structural design. Several researchers like Wang et al. [121] first applied  $\alpha$ -cut method to structural designs where the non-linear problems were solved with various design levels  $\alpha$ , and then a sequence of solutions were obtained by setting different level-cut value of  $\alpha$ . Rao [89] applied the same  $\alpha$ -cut method to design a four-bar mechanism for function generating problem. Structural optimization with fuzzy parameters was developed by Yeh et al. [131]. Xu [13] used two-phase method for fuzzy optimization of structures. Shih et al. [96] used level-cut approach of the first and second kind for structural design optimization problems with fuzzy resources. Shih et al. [95] developed alternative  $\alpha$ -level-cuts methods for optimum structural design with fuzzy resources. Dey et al. [35] used generalized fuzzy number in context of a structural design. Dey et al.[33]used basic t-norm based fuzzy optimization technique for optimization of structure.

In such extension, Atanassov [1] introduced Intuitionistic Fuzzy Set (IFS) which is one of the generalizations of fuzzy set theory and is characterized by a membership function, a non-membership function and a hesitancy function. In FS the degree of acceptance is only considered but IFS is characterized by a membership function and a non-membership function so that the sum of both values is less than one. A transportation model was solved by Jana et al.[57]using multi-objective intuitionistic fuzzy linear programming. Dey et al. [35] solved two bar truss non-linear problem by using Intuitionistic Fuzzy Optimization



problem. Dey et al. [36] used IFO technique for multi objective optimum structural design. IFS consider both truth membership and falsity membership. IFS can only handle incomplete information not the indeterminate information and inconsistent information.

In neutrosophic sets indeterminacy is quantified explicitly and truth membership, indeterminacy membership and falsity membership which are independent. Neutrosophic theory was introduced by Smarandache [94]. The motivation of the present study of this chapter is to give computational algorithm for solving multi-objective structural problem by single valued Neutrosophic Optimization(NSO) approach. NSO technique is very rare in application to structural optimization. We also aim to study the impact of truth exponential membership, indeterminacy exponential membership and falsity hyperbolic membership function in such optimization process. The results are compared numerically linear and nonlinear NSO technique. From our numerical result, it has been seen that there is no change between the result of linear and non-linear neutrosophic optimization technique in the perspective of structural optimization technique.

#### 4.1 General form of Multi-objective Truss Design Model

In the design problem of the structure i.e. lightest weight of the structure and minimum deflection of the loaded joint that satisfies all stress constraints in members of the structure. In truss structure system ,the basic parameters (including allowable stress ,etc) are known and the optimization's target is to identify the optimal bar truss cross-section area so that the structure is of the smallest total weight with minimum nodes displacement in a given load conditions .

The multi-objective structural model can be expressed as

**(P4.1)**

$$\text{Minimize } WT(A) \tag{4.1}$$

$$\text{Minimize } \delta(A) \tag{4.2}$$

$$\text{subject to } \sigma(A) \leq [\sigma] \tag{4.3}$$

$$A^{\min} \leq A \leq A^{\max} \tag{4.4}$$

where  $A = [A_1, A_2, \dots, A_n]^T$  are the design variables for the cross section, n is the group number of design variables for the cross section bar ,

$$WT(A) = \sum_{i=1}^n \rho_i A_i L_i \quad (4.5)$$

is the total weight of the structure,  $\delta(A)$  is the deflection of the loaded joint, where  $L_i, A_i$  and  $\rho_i$  are the bar length, cross section area and density of the  $i^{th}$  group bars respectively.  $\sigma(A)$  is the stress constraint and  $[\sigma]$  is allowable stress of the group bars under various conditions,  $A^{\min}$  and  $A^{\max}$  are the lower and upper bounds of cross section area  $A$  respectively.

## 4.2 Solution of Multi-objective Structural Optimization Problem (MOSOP) by Neutrosophic Optimization Technique

To solve the MOSOP (P4.1), step 1 of 1.33 is used. After that pay off matrix is formulated.

$$\begin{array}{cc} WT(A) & \delta(A) \\ A^1 \left[ \begin{array}{cc} WT^*(A^1) & \delta(A^1) \end{array} \right] \\ A^2 \left[ \begin{array}{cc} WT(A^2) & \delta^*(A^2) \end{array} \right] \end{array}$$

According to step-2 the bound of weight objective  $U_{WT}^T, L_{WT}^T; U_{WT}^I, L_{WT}^I$  and  $U_{WT}^F, L_{WT}^F$  for truth, indeterminacy and falsity membership function have been calculated respectively so that

$L_{WT}^T \leq WT(A) \leq U_{WT}^T; L_{WT}^I \leq WT(A) \leq U_{WT}^I; L_{WT}^F \leq WT(A) \leq U_{WT}^F$ . Similarly the bound of deflection objective are  $U_{\delta}^T, L_{\delta}^T; U_{\delta}^I, L_{\delta}^I$  and  $U_{\delta}^F, L_{\delta}^F$  respectively for truth, indeterminacy and falsity membership function. Then  $L_{\delta}^T \leq \delta(A) \leq U_{\delta}^T; L_{\delta}^I \leq \delta(A) \leq U_{\delta}^I; L_{\delta}^F \leq \delta(A) \leq U_{\delta}^F$ . Where

for Model-I,II-AL,AN

$$U_{WT}^F = U_{WT}^T, \quad (4.6)$$

$$L_{WT}^F = L_{WT}^T + \varepsilon_{WT}; \quad (4.7)$$

$$L_{WT}^I = L_{WT}^T, \quad (4.8)$$

$$U_{WT}^I = L_{WT}^T + \xi_{WT} \quad (4.9)$$

Such that  $0 < \varepsilon_{WT}, \xi_{WT} < (U_{WT}^T - L_{WT}^T)$

for Model-I,II-BL,BN

$$U_{WT}^F = U_{WT}^T = U_{WT}^I$$

$$L_{WT}^F = L_{WT}^T - \varepsilon_{WT} \text{ where } 0 < \varepsilon_{WT} < (U_{WT}^T - L_{WT}^T)$$

$$L_{WT}^I = L_{WT}^T - \xi_{WT} \text{ where } 0 < \xi_{WT} < (U_{WT}^T - L_{WT}^T)$$

And for Model-I,II-AL,AL

$$U_{\delta}^F = U_{\delta}^T, \tag{4.10}$$

$$L_{\delta}^F = L_{\delta}^T + \varepsilon_{\delta}; \tag{4.11}$$

$$L_{\delta}^I = L_{\delta}^T, \tag{4.12}$$

$$U_{\delta}^I = L_{\delta}^T + \xi_{\delta}$$

such that

$$0 < \varepsilon_{\delta}, \xi_{\delta} < (U_{\delta}^T - L_{\delta}^T). \tag{4.13}$$

for Model-I,II-BL,BN

$$U_{\delta}^F = U_{\delta}^T = U_{\delta}^I$$

$$L_{\delta}^F = L_{\delta}^T - \varepsilon_{\delta} \text{ where } 0 < \varepsilon_{\delta} < (U_{\delta}^T - L_{\delta}^T)$$

$$L_{\delta}^I = L_{\delta}^T - \xi_{\delta} \text{ where } 0 < \xi_{\delta} < (U_{\delta}^T - L_{\delta}^T)$$

Therefore the truth, indeterminacy and falsity membership functions for objectives are

$$T_{WT(A)}(WT(A)) = \begin{cases} 1 & \text{if } WT(A) \leq L_{WT(A)}^T \\ 1 - \exp\left\{-\psi\left(\frac{U_{WT(A)}^T - WT(A)}{U_{WT(A)}^T - L_{WT(A)}^T}\right)\right\} & \text{if } L_{WT(A)}^T \leq WT(A) \leq U_{WT(A)}^T \\ 0 & \text{if } WT(A) \geq U_{WT(A)}^T \end{cases} \tag{4.14}$$

for Model-I,II-AN

$$I_{WT(A)}(WT(A)) = \begin{cases} 1 & \text{if } WT(A) \leq L_{WT(A)}^T \\ \exp\left\{\frac{\left(L_{WT(A)}^T + \xi_{WT}\right) - WT(A)}{\xi_{WT}}\right\} & \text{if } L_{WT(A)}^T \leq WT(A) \leq L_{WT(A)}^T + \xi_{WT} \\ 0 & \text{if } WT(A) \geq L_{WT(A)}^T + \xi_{WT} \end{cases} \tag{4.15}$$

for Model-I,II-BN

$$I_{WT(A)}(WT(A)) = \begin{cases} 1 & \text{if } WT(A) \geq U_{WT(A)}^T \\ \exp\left\{\frac{WT(A) - (L_{WT(A)}^T + \xi_{WT})}{U_{WT(A)}^T - L_{WT(A)}^T - \xi_{WT}}\right\} & \text{if } L_{WT(A)}^T + \xi_{WT} \leq WT(A) \leq U_{WT(A)}^T \\ 0 & \text{if } WT(A) \leq L_{WT(A)}^T + \xi_{WT} \end{cases} \quad (4.16)$$

$$F_{WT(A)}(WT(A)) = \begin{cases} 0 & \text{if } WT(A) \leq L_{WT(A)}^T + \varepsilon_{WT} \\ \frac{1}{2} + \frac{1}{2} \tanh\left\{\left(WT(A) - \frac{(U_{WT(A)}^T + L_{WT(A)}^T) + \varepsilon_{WT}}{2}\right) \tau_{WT}\right\} & \text{if } L_{WT(A)}^T + \varepsilon_{WT} \leq WT(A) \leq U_{WT(A)}^T \\ 1 & \text{if } WT(A) \geq U_{WT(A)}^T \end{cases} \quad (4.17)$$

where  $0 < \varepsilon_{WT}, \xi_{WT} < (U_{WT}^T - L_{WT}^T)$

and

$$T_{\delta(A)}(\delta(A)) = \begin{cases} 1 & \text{if } \delta(A) \leq L_{\delta}^T \\ 1 - \exp\left\{-\psi\left(\frac{U_{\delta}^T - \delta(A)}{U_{\delta}^T - L_{\delta}^T}\right)\right\} & \text{if } L_{\delta}^T \leq \delta(A) \leq U_{\delta}^T \\ 0 & \text{if } \delta(A) \geq U_{\delta}^T \end{cases} \quad (4.18)$$

for Model-I,II-AN

$$I_{\delta(A)}(\delta(A)) = \begin{cases} 1 & \text{if } \delta(A) \leq L_{\delta}^T \\ \exp\left\{\frac{(L_{\delta}^T + \xi_{\delta}) - \delta(A)}{\xi_{\delta}}\right\} & \text{if } L_{\delta}^T \leq \delta(A) \leq L_{\delta}^T + \xi_{\delta} \\ 0 & \text{if } \delta(A) \geq L_{\delta}^T + \xi_{\delta} \end{cases} \quad (4.19)$$

for Model-I,II-BN

$$I_{\delta(A)}(\delta(A)) = \begin{cases} 1 & \text{if } \delta(A) \geq U_{\delta}^T \\ \exp\left\{\frac{\delta(A) - (L_{\delta}^T + \xi_{\delta})}{U_{\delta}^T - L_{\delta}^T - \xi_{\delta}}\right\} & \text{if } L_{\delta}^T + \xi_{\delta} \leq \delta(A) \leq U_{\delta}^T \\ 0 & \text{if } \delta(A) \leq L_{\delta}^T + \xi_{\delta} \end{cases} \quad (4.20)$$

$$F_{\delta(A)}(\delta(A)) = \begin{cases} 0 & \text{if } \delta(A) \leq L_{\delta}^T + \varepsilon_{\delta} \\ \frac{1}{2} + \frac{1}{2} \tanh \left\{ \left( \delta(A) - \frac{(U_{\delta}^T + L_{\delta}^T) + \varepsilon_{\delta}}{2} \right) \tau_{\delta} \right\} & \text{if } L_{\delta}^T + \varepsilon_{\delta} \leq \delta(A) \leq U_{\delta}^T \\ 1 & \text{if } \delta(A) \geq U_{\delta}^T \end{cases} \quad (4.21)$$

where  $\psi, \tau$  are non-zero parameters prescribed by the decision maker and for where  $0 < \varepsilon_{\delta}, \xi_{\delta} < (U_{\delta}^T - L_{\delta}^T)$ .

According to Smarandach's definition of intersection and decision making criteria, considering truth, indeterminacy and falsity membership function for MOSOP (P4.1), crisp NLP problem can be formulated as

#### Model-I-AN,BN

##### (P4.2)

$$\text{Maximize } (\alpha + \gamma - \beta) \quad (4.22)$$

Subject to

$$T_{WT}(WT(A)) \geq \alpha; \quad (4.23)$$

$$T_{\delta}(\delta(A)) \geq \alpha; \quad (4.24)$$

$$I_{WT}(WT(A)) \geq \gamma; \quad (4.25)$$

$$I_{\delta}(\delta(A)) \geq \gamma; \quad (4.26)$$

$$F_{WT}(WT(A)) \leq \beta; \quad (4.27)$$

$$F_{\delta}(\delta(A)) \leq \beta; \quad (4.28)$$

$$\sigma(A) \leq [\sigma]; \quad (4.29)$$

$$\alpha + \beta + \gamma \leq 3; \quad (4.30)$$

$$\alpha \geq \beta; \quad (4.31)$$

$$\alpha \geq \gamma; \quad (4.32)$$

$$\alpha, \beta, \gamma \in [0, 1], \quad (4.33)$$

$$A^{\min} \leq A \leq A^{\max} \quad (4.34)$$

Where Model-I-AN, Model-I-BN stands for the neutrosophic optimization algorithm with decreasing indeterminacy membership function and increasing indeterminacy membership function.

which is reduced to equivalent NLP problem as

**Model-I-AN**

**(P4.3)**

$$\text{Maximize } (\theta + \kappa - \eta) \quad (4.35)$$

Such that

$$WT(A) + \theta \frac{(U_{WT(A)}^T - L_{WT(A)}^T)}{\psi} \leq U_{WT(A)}^T; \quad (4.36)$$

$$WT(A) + \frac{\eta}{\tau_{WT(A)}} \leq \frac{U_{WT(A)}^T + L_{WT(A)}^T + \varepsilon_{WT(A)}}{2}; \quad (4.37)$$

$$WT(A) + \kappa \xi_{WT(A)} \leq L_{WT(A)}^T + \xi_{WT(A)}; \quad (4.38)$$

$$\delta(A) + \theta \frac{(U_{\delta}^T - L_{\delta}^T)}{\psi} \leq U_{\delta}^T; \quad (4.39)$$

$$\delta(A) + \kappa \xi_{\delta} \leq L_{\delta}^T + \xi_{\delta}; \quad (4.40)$$

$$\delta(A) + \frac{\eta}{\tau_{\delta}} \leq \frac{U_{\delta}^T + L_{\delta}^T + \varepsilon_{\delta}}{2};$$

(4.41)

$$\sigma(A) \leq [\sigma]; \quad (4.42)$$

$$\theta + \kappa - \eta \leq 3; \quad (4.43)$$

$$\theta \geq \kappa; \theta \geq \eta; \quad (4.44)$$

$$\theta, \kappa, \eta \in [0, 1] \quad (4.45)$$

$$\text{where } \theta = -\ln(1 - \alpha); \quad (4.46)$$

$$\psi = 4; \quad (4.47)$$

$$\tau_{WT} = \frac{6}{(U_{WT}^F - L_{WT}^F)}; \quad (4.48)$$

$$\tau_{\delta} = \frac{6}{(U_{\delta}^F - L_{\delta}^F)}; \quad (4.49)$$

$$\kappa = \ln \gamma; \quad (4.50)$$

$$\eta = -\tanh^{-1}(2\beta - 1). \quad (4.51)$$

And

#### Model-I-BN

##### (P4.4)

$$\text{Maximize } (\theta + \kappa - \eta) \quad (4.52)$$

Such that

$$WT(A) + \theta \frac{(U_{WT(A)}^T - L_{WT(A)}^T)}{\psi} \leq U_{WT(A)}^T; \quad (4.53)$$

$$WT(A) + \frac{\eta}{\tau_{WT(A)}} \leq \frac{U_{WT(A)}^T + L_{WT(A)}^T + \varepsilon_{WT(A)}}{2}; \quad (4.54)$$

$$WT(A) - \kappa (U_{WT(A)}^T - L_{WT(A)}^T - \xi_{WT(A)}) \geq L_{WT(A)}^T + \xi_{WT(A)}; \quad (4.55)$$

$$\delta(A) + \theta \frac{(U_{\delta}^T - L_{\delta}^T)}{\psi} \leq U_{\delta}^T; \quad (4.56)$$

$$\delta(A) - \kappa (U_{\delta}^T - L_{\delta}^T - \xi_{\delta}) \geq L_{\delta}^T + \xi_{\delta}; \quad (4.57)$$

$$\delta(A) + \frac{\eta}{\tau_{\delta}} \leq \frac{U_{\delta}^T + L_{\delta}^T + \varepsilon_{\delta}}{2}; \quad (4.58)$$

$$\sigma(A) \leq [\sigma]; \quad (4.59)$$

$$\theta + \kappa - \eta \leq 3; \quad (4.60)$$

$$\theta \geq \kappa; \theta \geq \eta; \quad (4.61)$$

$$\theta, \kappa, \eta \in [0, 1] \quad (4.62)$$

$$\text{where } \theta = -\ln(1 - \alpha); \quad (4.63)$$

$$\psi = 4; \quad (4.64)$$

$$\tau_{WT} = \frac{6}{(U_{WT}^F - L_{WT}^F)}; \quad (4.15)$$

$$\tau_{\delta} = \frac{6}{(U_{\delta}^F - L_{\delta}^F)}; \quad (4.66)$$

$$\kappa = \ln \gamma; \quad (4.67)$$

$$\eta = -\tanh^{-1}(2\beta - 1). \quad (4.68)$$

But as the decision maker needs to minimize indeterminacy membership function in an optimization problem another form of NSO algorithm can be formulated as

### Model-II-AN

#### (P4.5)

$$\text{Maximize } (\theta - \kappa - \eta) \quad (4.69)$$

Such that

$$WT(A) + \theta \frac{(U_{WT(A)}^T - L_{WT(A)}^T)}{\psi} \leq U_{WT(A)}^T; \quad (4.70)$$

$$WT(A) + \frac{\eta}{\tau_{WT(A)}} \leq \frac{U_{WT(A)}^T + L_{WT(A)}^T + \varepsilon_{WT(A)}}{2}; \quad (4.71)$$

$$WT(A) + \kappa \xi_{WT(A)} \geq L_{WT(A)}^T + \xi_{WT(A)}; \quad (4.72)$$

$$\delta(A) + \theta \frac{(U_{\delta}^T - L_{\delta}^T)}{\psi} \leq U_{\delta}^T; \quad (4.73)$$

$$\delta(A) + \kappa \xi_{\delta} \geq L_{\delta}^T + \xi_{\delta}; \quad (4.74)$$

$$\delta(A) + \frac{\eta}{\tau_{\delta}} \leq \frac{U_{WT}^T + L_{WT}^T + \varepsilon_{\delta}}{2};$$

(4.75)

$$\sigma(A) \leq [\sigma]; \quad (4.76)$$

$$\theta + \kappa - \eta \leq 3; \quad (4.77)$$

$$\theta \geq \kappa; \theta \geq \eta; \quad (4.78)$$

$$\theta, \kappa, \eta \in [0, 1] \quad (4.79)$$



$$\text{where } \theta = -\ln(1-\alpha); \quad (4.80)$$

$$\psi = 4; \quad (4.81)$$

$$\tau_{WT} = \frac{6}{(U_{WT}^F - L_{WT}^F)}; \quad (4.82)$$

$$\tau_{\delta} = \frac{6}{(U_{\delta}^F - L_{\delta}^F)}; \quad (4.83)$$

$$\kappa = \ln \gamma; \quad (4.84)$$

$$\eta = -\tanh^{-1}(2\beta-1). \quad (4.85)$$

And

### Model-II-BN

#### (P4.6)

$$\text{Maximize } (\theta - \kappa - \eta) \quad (4.86)$$

Such that

$$WT(A) + \theta \frac{(U_{WT(A)}^T - L_{WT(A)}^T)}{\psi} \leq U_{WT(A)}^T; \quad (4.87)$$

$$WT(A) + \frac{\eta}{\tau_{WT(A)}} \leq \frac{U_{WT(A)}^T + L_{WT(A)}^T + \varepsilon_{WT(A)}}{2}; \quad (4.89)$$

$$WT(A) - \kappa (U_{WT(A)}^T - L_{WT(A)}^T - \xi_{WT(A)}) \leq L_{WT(A)}^T + \xi_{WT(A)}; \quad (4.90)$$

$$\delta(A) + \theta \frac{(U_{\delta}^T - L_{\delta}^T)}{\psi} \leq U_{\delta}^T; \quad (4.91)$$

$$\delta(A) - \kappa (U_{\delta}^T - L_{\delta}^T - \xi_{\delta}) \leq L_{\delta}^T + \xi_{\delta}; \quad (4.92)$$

$$\delta(A) + \frac{\eta}{\tau_{\delta}} \leq \frac{U_{WT}^T + L_{WT}^T + \varepsilon_{\delta}}{2}; \quad (4.93)$$

$$\sigma(A) \leq [\sigma]; \quad (4.94)$$

$$\theta + \kappa - \eta \leq 3; \quad (4.95)$$

$$\theta \geq \kappa; \theta \geq \eta; \quad (4.96)$$

$$\theta, \kappa, \eta \in [0, 1] \quad (4.97)$$

$$\text{where } \theta = -\ln(1-\alpha); \quad (4.98)$$

$$\psi = 4; \quad (4.99)$$

$$\tau_{WT} = \frac{6}{(U_{WT}^F - L_{WT}^F)}; \quad (4.100)$$

$$\tau_{\delta} = \frac{6}{(U_{\delta}^F - L_{\delta}^F)}; \quad (4.101)$$

$$\kappa = \ln \gamma; \quad (4.102)$$

$$\eta = -\tanh^{-1}(2\beta - 1). \quad (4.103)$$

Solving the above crisp model (P4.3),(P4.4),(P4.5),(P4.6) we get optimal solution and hence objective functions i.e structural weight and deflection of the loaded joint will attain its optimum value

### 4.3 Numerical Solution of Multi-objective Structural Optimization Problem (MOSOP) by Neutrosophic Optimization Technique

A well-known three bar planer truss [Fig.-4.1]is considered to minimize weight of the structure  $WT(A_1, A_2)$  and minimize the deflection  $\delta(A_1, A_2)$  at a loading point of a statistically loaded three bar planer truss, subject to stress constraints on each of the truss members

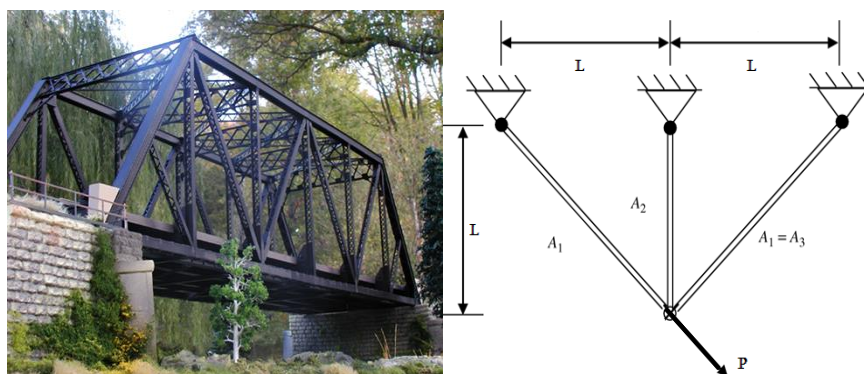

Fig.-4.1 Design of the Three-Bar Planar Truss(Pratt Truss Bridge, <http://www.atlaso.com>, accessed on 17 June 2017)

The multi-objective optimization problem can be stated as follows

$$(P4.7)$$

$$\text{Minimize } WT(A_1, A_2) = \rho L(2\sqrt{2}A_1 + A_2) \quad (4.104)$$

$$\text{Minimize } \delta(A_1, A_2) = \frac{PL}{E(A_1 + \sqrt{2}A_2)} \quad (4.105)$$

Subject to

$$\sigma_1(A_1, A_2) = \frac{P(\sqrt{2}A_1 + A_2)}{(2A_1^2 + 2A_1A_2)} \leq [\sigma_1^T]; \quad (4.106)$$

$$\sigma_2(A_1, A_2) = \frac{P}{(A_1 + \sqrt{2}A_2)} \leq [\sigma_2^T]; \quad (4.107)$$

$$\sigma_3(A_1, A_2) = \frac{PA_2}{(2A_1^2 + 2A_1A_2)} \leq [\sigma_3^C]; \quad (4.108)$$

$$A_i^{\min} \leq A_i \leq A_i^{\max} \quad i = 1, 2 \quad (4.109)$$

where  $P$  = applied load ;  $\rho$  = material density ;  $L$  = length ;  $E$  = Young's modulus ;  $A_1$  = Cross section of bar-1 and bar-3;  $A_2$  = Cross section of bar-2;  $\delta$  is deflection of loaded joint.  $[\sigma_1^T]$  and  $[\sigma_2^T]$  are maximum allowable tensile stress for bar 1 and bar 2 respectively,  $\sigma_3^C$  is maximum allowable compressive stress for bar 3.

**Table 4.1 Input Data for Crisp Model (P4.4)**

Applied load $P$ (KN)	Volume density $\rho$ (KN/m <sup>3</sup> )	Length $L$ (m)	Maximum allowable tensile stress $[\sigma_1^T]$ (KN/m <sup>2</sup> )	Maximum allowable compressive stress $[\sigma_3^C]$ (KN/m <sup>2</sup> )	Young's modulus $E$ (KN/m <sup>2</sup> )	$A_i^{\min}$ and $A_i^{\max}$ of cross section of bars (10 <sup>-4</sup> m <sup>2</sup> )
20	100	1	20	15	$2 \times 10^7$	$A_1^{\min} = 0.1$ $A_1^{\max} = 5$ $A_2^{\min} = 0.1$ $A_2^{\max} = 5$

Solution : According to step 2 of 1.33, pay-off matrix is formulated as follows

$$\begin{matrix} & WT(A_1, A_2) & \delta(A_1, A_2) \\ A^1 & \left[ \begin{matrix} 2.638958 & 14.64102 \end{matrix} \right] \\ A^2 & \left[ \begin{matrix} 19.14214 & 1.656854 \end{matrix} \right] \end{matrix}.$$

Here

$$U_{WT}^F = U_{WT}^T = 19.14214, \quad (4.110)$$

$$L_{WT}^F = L_{WT}^T + \varepsilon_1 = 2.638958 + \varepsilon_1; \quad (4.111)$$

$$L_{WT}^I = L_{WT}^T = 2.638958, \quad (4.112)$$

$$U_{WT}^I = L_{WT}^T + \xi_1 = 2.638958 + \xi_1 \quad (4.113)$$

such that  $0 < \varepsilon_1, \xi_1 < (19.14214 - 2.638958)$ ;

$$U_{\delta}^F = U_{\delta}^T = 14.64102,$$

(4.114)

$$L_{\delta}^F = L_{\delta}^T + \varepsilon_2 = 1.656854 + \varepsilon_2; \quad (4.115)$$

$$L_{\delta}^I = L_{\delta}^T = 1.656854, \quad (4.116)$$

$$U_{\delta}^I = L_{\delta}^T + \xi_2 = 1.656854 + \xi_2 \quad (4.117)$$

such that  $0 < \varepsilon_2, \xi_2 < (14.64102 - 1.656854)$  (4.118)

Here truth, indeterminacy, and falsity membership function for objective functions

$WT(A_1, A_2), \delta(A_1, A_2)$  are defined as follows

$$T_{WT(A_1, A_2)}(WT(A_1, A_2)) = \begin{cases} 1 & \text{if } WT(A_1, A_2) \leq 2.638958 \\ 1 - \exp\left\{-4\left(\frac{19.14214 - WT(A_1, A_2)}{16.503182}\right)\right\} & \text{if } 2.638958 \leq WT(A_1, A_2) \leq 19.14214 \\ 0 & \text{if } WT(A_1, A_2) \geq 19.14214 \end{cases} \quad (4.119)$$

$$I_{WT(A_1, A_2)}(WT(A_1, A_2)) = \begin{cases} 1 & \text{if } WT(A_1, A_2) \leq 2.638958 \\ \exp\left\{\frac{(2.638958 + \xi_1) - WT(A_1, A_2)}{\xi_1}\right\} & \text{if } 2.638958 \leq WT(A_1, A_2) \leq 2.638958 + \xi_1 \\ 0 & \text{if } WT(A_1, A_2) \geq 2.638958 + \xi_1 \end{cases} \quad (4.120)$$

$$F_{WT(A_1, A_2)}(WT(A_1, A_2)) = \begin{cases} 0 & \text{if } WT(A_1, A_2) \leq 2.638958 \\ \frac{1}{2} + \frac{1}{2} \tanh \left\{ \left( WT(A_1, A_2) - \frac{21.781098 + \varepsilon_1}{2} \right) \frac{6}{(16.503182 - \varepsilon_1)} \right\} & \text{if } 2.638958 \leq WT(A_1, A_2) \leq 19.14214 \\ 1 & \text{if } WT(A_1, A_2) \geq 19.14214 \end{cases} \quad (4.121)$$

$$0 < \varepsilon_1, \xi_1 < 16.503182$$

and

$$T_{\delta(A_1, A_2)}(\delta(A_1, A_2)) = \begin{cases} 1 & \text{if } \delta(A_1, A_2) \leq 1.656854 \\ 1 - \exp \left\{ -4 \left( \frac{14.64102 - \delta(A_1, A_2)}{12.984166} \right) \right\} & \text{if } 1.656854 \leq \delta(A_1, A_2) \leq 14.64102 \\ 0 & \text{if } \delta(A_1, A_2) \geq 14.64102 \end{cases} \quad (4.122)$$

For Model-I,II-AN

$$I_{\delta(A_1, A_2)}(\delta(A_1, A_2)) = \begin{cases} 1 & \text{if } \delta(A_1, A_2) \leq 1.656854 \\ \exp \left\{ \frac{(1.656854 + \xi_2) - \sigma_T(A_1, A_2)}{\xi_2} \right\} & \text{if } 130 \leq \delta(A_1, A_2) \leq 1.656854 + \xi_2 \\ 0 & \text{if } \delta(A_1, A_2) \geq 1.656854 + \xi_2 \end{cases} \quad (4.123)$$

For Model-I,II-BN

$$I_{\delta(A_1, A_2)}(\delta(A_1, A_2)) = \begin{cases} 1 & \text{if } \delta(A_1, A_2) \geq 14.64102 \\ \exp \left\{ \frac{\sigma_T(A_1, A_2) - (1.656854 + \xi_2)}{12.984166 - \xi_2} \right\} & \text{if } 1.656854 + \xi_2 \leq \delta(A_1, A_2) \leq 14.64102 \\ 0 & \text{if } \delta(A_1, A_2) \leq 1.656854 + \xi_2 \end{cases} \quad (4.124)$$

$$F_{\delta(A_1, A_2)}(\delta(A_1, A_2)) = \begin{cases} 0 & \text{if } \delta(A_1, A_2) \leq 1.656854 + \varepsilon_2 \\ \frac{1}{2} + \frac{1}{2} \tanh \left\{ \left( \delta(A_1, A_2) - \frac{16.297874 + \varepsilon_2}{2} \right) \frac{6}{12.984166 - \varepsilon_2} \right\} & \text{if } 1.656854 + \varepsilon_2 \leq \delta(A_1, A_2) \leq 14.64102 \\ 1 & \text{if } \delta(A_1, A_2) \geq 14.64102 \end{cases} \quad (4.125)$$

$$0 < \varepsilon_2, \xi_2 < 12.9842$$

According to NSO the MOSOP (P4.7) can be formulated as

**Model-I-AN**

**(P4.8)**

$$\text{Maximize } (\theta + \kappa - \eta) \quad (4.126)$$

$$(2\sqrt{2}A_1 + A_2) + 4.1257\theta \leq 19.14214;$$

(4.127)

$$(2\sqrt{2}A_1 + A_2) + \frac{\eta(16.503182 - \varepsilon_1)}{6} \leq \frac{(21.781098 + \varepsilon_1)}{2}; \quad (4.128)$$

$$(2\sqrt{2}A_1 + A_2) + \kappa\xi_1 \leq (2.638958 + \xi_1);$$

(4.129)

$$\frac{20}{(A_1 + \sqrt{2}A_2)} + 3.2460415\theta \leq 14.64102; \quad (4.130)$$

$$\frac{20}{(A_1 + \sqrt{2}A_2)} + \frac{\eta(12.984166 - \varepsilon_2)}{6} \leq \frac{(16.297874 + \varepsilon_2)}{2}; \quad (4.131)$$

$$\frac{20}{(A_1 + \sqrt{2}A_2)} + \kappa\xi_2 \leq (1.656854 + \xi_2); \quad (4.132)$$

$$\frac{20(\sqrt{2}A_1 + A_2)}{(2A_1^2 + 2A_1A_2)} \leq 20; \quad (4.133)$$

$$\frac{20}{(A_1 + \sqrt{2}A_2)} \leq 20; \quad (4.134)$$

$$\frac{20A_2}{(2A_1^2 + 2A_1A_2)} \leq 15; \quad (4.135)$$

$$\theta + \kappa + \eta \leq 3; \quad (4.136)$$

$$\theta \geq \kappa; \theta \geq \eta \quad (4.137)$$

$$0.1 \leq A_1, A \leq 5 \quad (4.138)$$

### Model-I-BN

(P4.9)

$$\text{Maximize } (\theta + \kappa - \eta) \quad (4.139)$$

$$(2\sqrt{2}A_1 + A_2) + 4.1257\theta \leq 19.14214;$$

(4.140)

$$(2\sqrt{2}A_1 + A_2) + \frac{\eta(16.503182 - \varepsilon_1)}{6} \leq \frac{(21.781098 + \varepsilon_1)}{2}; \quad (4.141)$$

$$(2\sqrt{2}A_1 + A_2) - \kappa(16.503182 - \xi_1) \geq (2.638958 + \xi_1); \quad (4.142)$$

$$\frac{20}{(A_1 + \sqrt{2}A_2)} + 3.2460415\theta \leq 14.64102; \quad (4.143)$$

$$\frac{20}{(A_1 + \sqrt{2}A_2)} + \frac{\eta(12.984166 - \varepsilon_2)}{6} \leq \frac{(16.297874 + \varepsilon_2)}{2}; \quad (4.144)$$

$$\frac{20}{(A_1 + \sqrt{2}A_2)} - \kappa(12.984166 - \xi_2) \geq (1.656854 + \xi_2); \quad (4.145)$$

$$\frac{20(\sqrt{2}A_1 + A_2)}{(2A_1^2 + 2A_1A_2)} \leq 20; \quad (4.146)$$

$$\frac{20}{(A_1 + \sqrt{2}A_2)} \leq 20; \quad (4.147)$$

$$\frac{20A_2}{(2A_1^2 + 2A_1A_2)} \leq 15; \quad (4.148)$$

$$\theta + \kappa + \eta \leq 3; \quad (4.149)$$

$$\theta \geq \kappa; \theta \geq \eta \quad (4.150)$$

$$0.1 \leq A_1, A \leq 5 \quad (4.151)$$

#### Model-II-AN

##### (P4.10)

$$\text{Maximize } (\theta - \kappa - \eta) \quad (4.152)$$

$$(2\sqrt{2}A_1 + A_2) + 4.1257\theta \leq 19.14214; \quad (4.153)$$

$$(2\sqrt{2}A_1 + A_2) + \frac{\eta(16.503182 - \varepsilon_1)}{6} \leq \frac{(21.781098 + \varepsilon_1)}{2}; \quad (4.154)$$

$$(2\sqrt{2}A_1 + A_2) + \kappa\xi_1 \geq (2.638958 + \xi_1); \quad (4.155)$$

$$\frac{20}{(A_1 + \sqrt{2}A_2)} + 3.2460415\theta \leq 14.64102; \quad (4.156)$$

$$\frac{20}{(A_1 + \sqrt{2}A_2)} + \frac{\eta(12.984166 - \varepsilon_2)}{6} \leq \frac{(16.297874 + \varepsilon_2)}{2}; \quad (4.157)$$

$$\frac{20}{(A_1 + \sqrt{2}A_2)} + \kappa\xi_2 \geq (1.656854 + \xi_2); \quad (4.158)$$

$$\frac{20(\sqrt{2}A_1 + A_2)}{(2A_1^2 + 2A_1A_2)} \leq 20; \quad (4.159)$$

$$\frac{20}{(A_1 + \sqrt{2}A_2)} \leq 20; \quad (4.160)$$

$$\frac{20A_2}{(2A_1^2 + 2A_1A_2)} \leq 15; \quad (4.161)$$

$$\theta + \kappa + \eta \leq 3; \quad (4.162)$$

$$\theta \geq \kappa; \theta \geq \eta \quad (4.163)$$

$$0.1 \leq A_1, A \leq 5 \quad (4.164)$$

### Model-II-BN

#### (P4.11)

$$\text{Maximize } (\theta + \kappa - \eta) \quad (4.165)$$

$$(2\sqrt{2}A_1 + A_2) + 4.1257\theta \leq 19.14214;$$

(4.166)

$$(2\sqrt{2}A_1 + A_2) + \frac{\eta(16.503182 - \varepsilon_1)}{6} \leq \frac{(21.781098 + \varepsilon_1)}{2}; \quad (4.167)$$

$$(2\sqrt{2}A_1 + A_2) - \kappa(16.503182 - \xi_1) \leq (2.638958 + \xi_1); \quad (4.168)$$

$$\frac{20}{(A_1 + \sqrt{2}A_2)} + 3.2460415\theta \leq 14.64102; \quad (4.169)$$

$$\frac{20}{(A_1 + \sqrt{2}A_2)} + \frac{\eta(12.984166 - \varepsilon_2)}{6} \leq \frac{(16.297874 + \varepsilon_2)}{2}; \quad (4.170)$$

$$\frac{20}{(A_1 + \sqrt{2}A_2)} - \kappa(12.984166 - \xi_2) \leq (1.656854 + \xi_2); \quad (4.171)$$

$$\frac{20(\sqrt{2}A_1 + A_2)}{(2A_1^2 + 2A_1A_2)} \leq 20; \quad (4.172)$$

$$\frac{20}{(A_1 + \sqrt{2}A_2)} \leq 20; \quad (4.173)$$

$$\frac{20A_2}{(2A_1^2 + 2A_1A_2)} \leq 15; \quad (4.174)$$



$$\theta + \kappa + \eta \leq 3; \tag{4.175}$$

$$\theta \geq \kappa; \theta \geq \eta \tag{4.176}$$

$$0.1 \leq A_1, A \leq 5$$

2

So , using above mentioned truth, indeterminacy and falsity membership function NLP (P4.7) can be solved by NSO technique for different values of  $\varepsilon_1, \varepsilon_2$  and  $\xi_1, \xi_2$ . The optimum solution of MOSOP(P4.7) is given in Table 4.2.

**Table 4.2 Comparison of Optimal solution of MOSOP (P4.7) based on Different Method**

Methods	$A_1$ $\times 10^{-4} m^2$	$A_2$ $\times 10^{-4} m^2$	$WT(A_1, A_2)$ $\times 10^2 KN$	$\delta(A_1, A_2)$ $\times 10^{-7} m$
Neutrosophic optimization (NSO) with linear membership function $\varepsilon_1 = 3.30064, \varepsilon_2 = 2.59696$ $\xi_1 = 1.65032, \xi_2 = 1.29848$	.5777658	2.655110	<b>4.289278</b>	2.955334
Neutrosophic optimization (NSO) with nonlinear membership function $\varepsilon_1 = 3.30064, \varepsilon_2 = 2.59696$ $\xi_1 = 1.65032, \xi_2 = 1.29848$ <b>Model-I-AN</b>	.5777658	2.655110	<b>4.289278</b>	2.955334
<b>Model-I-BN</b>	1.234568	1.234568	<b>4.062995</b>	6.710259
<b>Model-II-AN</b>	1.481133	1.10275	<b>3.931177</b>	6.577532
<b>Model-II-BN</b>	0.5777307	3.752957	<b>6.581384</b>	3.398347

Here we get same solutions for the different tolerance  $\xi_1, \xi_2$  and  $\xi_3$  for indeterminacy membership function of objective functions. From the Table 4.2, it shows that NSO technique gives same result for linear and non-linear membership functions in the perspective of Structural Optimization.

#### 4.4 Conclusion

Here we have considered a non-linear three bar truss design problem .In this test problem, we find out minimum weight of the structure as well as minimum deflection of loaded joint. The comparisons of results obtained for the undertaken problem clearly show the superiority of neutrosophic optimization over fuzzy optimization. The results of this study may lead to the development of effective neutrosophic technique for solving other model of nonlinear programming problem in different field.

# CHAPTER 5

---

## Optimization of Welded Beam Structure using Neutrosophic Optimization Technique: A Comparative Study

---

In today's highly competitive market, the pressure on a construction agency is to find better ways to attain the optimal solution. In conventional optimization problems, it is assumed that the decision maker is sure about the precise values of data involved in the model. But in real world applications all the parameters of the optimization problems may not be known precisely due to uncontrollable factors. Such type of imprecise data is well represented by fuzzy number introduced by Zadeh [133]. In reality, a decision maker may assume that an object belongs to a set to a certain degree, but it is probable that he is not sure about it. In other words, there may be uncertainty about the membership degree. The main premise is that the parameters' demand across the problem is uncertain. So, they are known to fall within a prescribed uncertainty set with some attributed degree. In Fuzzy Set (FS) theory, there is no means to incorporate this hesitation in the membership degree. To incorporate the uncertainty in the membership degree, Intuitionistic Fuzzy Sets (IFSs) proposed by Atanassov [1] is an extension of FS theory. In IFS theory along with degree of membership a degree of non-membership is usually considered to express ill-know quantity. This degree of membership and non-membership functions are so defined as they are independent to each other and sum of them is less or equal to one. So IFS is playing an important role in decision making under uncertainty and has gained popularity in recent years. However an application of the IFSs to optimization problems introduced by Angelov [4]. His technique is based on maximizing the degree of membership, minimizing the degree of non-membership and the crisp model is formulated using the IF aggregation operator. Now the fact is that in IFS indeterminate information is partially lost, as hesitant information is taken in consideration by default. So indeterminate information should be considered in decision making process. Smarandache [94] defined neutrosophic set that could handle indeterminate and inconsistent information. In neutrosophic sets indeterminacy is quantified explicitly as indeterminacy membership is considered along with truth membership, and falsity membership function independently Wang et.al [120] define single valued neutrosophic set which represents imprecise, incomplete, indeterminate, inconsistent information. Thus taking the universe as a real line

we can develop the concept of single valued neutrosophic set as special case of neutrosophic sets. This set is able to express ill-known quantity with uncertain numerical value in decision making problem. It helps more adequately to represent situations where decision makers abstain from expressing their assessments. In this way neutrosophic set provides a richer tool to grasp impression and ambiguity than the conventional FS as well as IFSs. Although exactly known, partially unknown and uncertain information handled by fully utilising the properties of transition rate matrices, together with the convexification of uncertain domains [121-123] ,NSO is more realistic in application of optimum design. These characteristics of neutrosophic set led to the extension of optimization methods in Neutrosophic environment (NSE). Besides It has been seen that the current research on fuzzy mathematical programming is limited to the range of linear programming introduced by Ziemmermann[136] . It has been shown that the solutions of Fuzzy Linear Programming Problems (FLPPs) are always efficient. The most common approach for solving fuzzy linear programming problem is to change it into corresponding crisp linear programming problem. But practically there exist so many nonlinear structural designs such as welded beam design problem in various fields of engineering. So development of nonlinear programming is also essential. Recently a robust and reliable static output feedback (SOF) control for nonlinear systems [124] and for continuous-time nonlinear stochastic systems [128] with actuator fault in a descriptor system framework have been studied. However welding can be defined as a process of joining metallic parts by heating to a suitable temperature with or without the application of pressure. This cost of welding should be economical and welded beam should be durable one.

Since decades, deterministic optimization has been widely used in practice for optimizing welded connection design. These include mathematical traditional optimization algorithms such as David-Fletcher-Powell with a penalty function (DAVID)[95],Griffith and Stewart's Successive Linear Approximation(APPROX) [95],Simplex Method with Penalty Function (SIMPLEX)[95],Recherdson's Random Method(RANDOM)[95],Harmony Search Method[67],GA based Method [37,16],Improved Harmony Search Algorithm [72],Simple Constrained Particle Swarm Optimizer(SiC-PSO)[25],Mezura [73],Constrained Optimization via PSO Algorithm(COPSO)[5],GA based on a co-evolution model(GA1)[14],GA through the use of dominance based tournament selection (GA2)[15],Evolutionary Programming with a cultural algorithm(EP)[16],Co-evolutionary Particle Swarm Optimization(CPSO)[51],Hybrid Particle swarm optimization (HPSO)with a feasibility based rule[52],Hybrid Nelder-Mead Simplex search method and particle swarm optimization(NM-PSO)[137],Particle Swarm Optimization(PSO)[38],Simulate Anneling(SA)[38],Goldlike

(GL)[38], Cuckoo Search(Cuckoo)[38], Firefly Algorithm(FF), Flower Pollination(FP)[38], Ant Lion Optimizer(ALO)[38], Gravitational Search Algorithm(GSA)[38], Multi-Verse Optimizer(MVO)[38] etc. All these deterministic optimizations aim to search the optimum solution under given constraints without consideration of uncertainties.

So these traditional techniques cannot be applicable in optimizing welded beam design when impreciseness is involved in information. Thus the research on optimization for nonlinear programming under fuzzy, IF and neutrosophic environment are not only necessary in the fuzzy optimization theory but also has great and wide value in application to welded beam design problem of conflicting and imprecise nature. This is the motivation of our present investigation. In this regard it can be cited that Das et al. [39] developed neutrosophic nonlinear programming with numerical example and application of real life problem recently. A single objective plane truss structure[97] and a multi-objective plane truss structure[98] have been optimized in IF environment. A multi-objective structural model has been optimized by IF mathematical programming with IF number for truss structure [99], welded beam structure[102] and neutrosophic number for truss design [101] as coefficient of objective by Sarkaret.al. With the help of linear membership[100] and nonlinear membership [103,104] for single objective truss design and multi-objective truss design[107] have been optimized in neutrosophic environment. A multi-objective goal programming technique[105] and T-norm, T-co-norm based IF optimization technique[107] have been developed to optimize cost of welding in neutrosophic and IF environment respectively.

The aim of this chapter is to show the efficiency of single objective NSO technique in finding optimum cost of welding of welded beam in imprecise environment and to make a comparison of results obtained in different deterministic methods.

## **5.1 Welded Beam Design (WBD) and its Optimization in Neutrosophic Environment**

Welding, a process of joining metallic parts with the application of heat or pressure or the both, with or without added material, is an economical and efficient method for obtaining permanent joints in the metallic parts. These welded joints are generally used as a substitute for riveted joint or can be used as an alternative method for casting or forging. The welding processes can broadly be classified into following two groups, the welding process that uses heat alone to join two metallic parts and the welding process that uses a combination of heat

and pressure for joining (Bhandari. V. B). However, above all the design of welded beam should preferably be economical and durable one.

### 5.1.1 Crisp Formulation of WBD

In design formulation a welded beam ([90],Fig.- 5.1) has to be designed at minimum cost whose constraints are shear stress in weld ( $\tau$ ), bending stress in the beam ( $\sigma$ ), buckling load

on the bar ( $P$ ), and deflection of the beam ( $\delta$ ). The design variables are  $\begin{bmatrix} x_1 \\ x_2 \\ x_3 \\ x_4 \end{bmatrix} = \begin{bmatrix} h \\ l \\ t \\ b \end{bmatrix}$  where  $h$  is

the weld size,  $l$  is the length of the weld,  $t$  is the depth of the welded beam,  $b$  is the width of the welded beam.

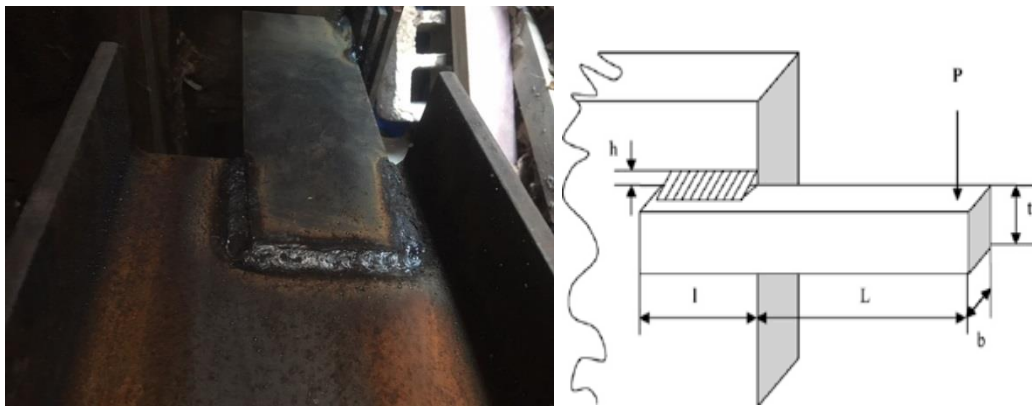

Fig.-5.1 Design of the Welded Beam

(<http://www.foundationrepairduluth.com>, accessed on 18 June 2017)

The single-objective crisp welded beam optimization problem can be formulated as follows

(P5.1)

$$\text{Minimize } C(X) \equiv 1.10471x_1^2x_2 + 0.04811(14 + x_2)x_3x_4 \quad (5.1)$$

such that

$$g_1(x) \equiv \tau(x) - \tau_{\max} \leq 0 \quad (5.2)$$

$$g_2(x) \equiv \sigma(x) - \sigma_{\max} \leq 0 \quad (5.3)$$

$$g_3(x) \equiv x_1 - x_4 \leq 0 \quad (5.4)$$

$$g_4(x) \equiv 0.10471x_1^2x_2 + 0.04811x_3x_4(14 + x_2) - 5 \leq 0 \quad (5.5)$$

$$g_5(x) \equiv 0.125 - x_1 \leq 0 \quad (5.6)$$

$$g_6(x) \equiv \delta(x) - \delta_{\max} \leq 0 \quad (5.7)$$

$$g_7(x) \equiv P - P_c(x) \leq 0 \quad (5.8)$$

$$x_1, x_2, x_3, x_4 \in [0, 1] \quad (5.9)$$

$$\text{where } \tau(x) = \sqrt{\tau_1^2 + 2\tau_1\tau_2 \frac{x_2}{2R} + \tau_2^2} ; \quad (5.10)$$

$$\tau_1 = \frac{P}{\sqrt{2}x_1x_2} ; \quad (5.11)$$

$$\tau_2 = \frac{MR}{J} ; \quad (5.12)$$

$$M = P \left( L + \frac{x_2}{2} \right) ; \quad (5.13)$$

$$R = \sqrt{\frac{x_2^2}{4} + \left( \frac{x_1 + x_3}{2} \right)^2} ; \quad (5.14)$$

$$J = \left\{ \frac{x_1x_2}{\sqrt{2}} \left[ \frac{x_2^2}{12} + \left( \frac{x_1 + x_3}{2} \right)^2 \right] \right\} ; \quad (5.15)$$

$$\sigma(x) = \frac{6PL}{x_4x_3^2} ;$$

(5.16)

$$\delta(x) = \frac{4PL^3}{Ex_4x_3^2} ; \quad (5.17)$$

$$P_c(x) = \frac{4.013\sqrt{EGx_3^6x_4^6/36}}{L^2} \left( 1 - \frac{x_3}{2L} \sqrt{\frac{E}{4G}} \right) . \quad (5.18)$$

Again  $P$  = Force on beam ;  $L$  = Beam length beyond weld;  $x_1$  = Height of the welded beam;  $x_2$  = Length of the welded beam;  $x_3$  = Depth of the welded beam;  $x_4$  = Width of the welded beam;  $\tau(x)$  = Design shear stress;  $\sigma(x)$  = Design normal stress for beam material;  $M$  =

Moment of  $P$  about the centre of gravity of the weld ,  $J$  = Polar moment of inertia of weld group;  $G$  = Shearing modulus of Beam Material;  $E$  = Young modulus;  $\tau_{\max}$  = Design Stress of the weld;  $\sigma_{\max}$  = Design normal stress for the beam material;  $\delta_{\max}$  = Maximum deflection;  $\tau_1$  = Primary stress on weld throat.  $\tau_2$  = Secondary torsional stress on weld.

### 5.1.2 WBD Formulation in Neutrosophic Environment

Sometimes slight change of stress or deflection enhances the weight of structures and indirectly cost of processing. In such situation when Decision Maker (DM) is in doubt to decide the stress constraint goal, the DM can induce the idea of acceptance boundary, hesitancy response or negative response margin of constraints goal. This fact seems to take the constraint goal as a NS instead of FS and IFS. It may be more realistic description than FS and IFS. When the shear stress, normal stress and deflection constraint goals are NS in nature the above crisp welded beam design (P5.1) can be formulated as

#### (P5.2)

$$\text{Minimize } C(X) \equiv 1.10471x_1^2x_2 + 0.04811(14 + x_2)x_3x_4 \quad (5.19)$$

Such that

$$g_1(x) \equiv \tau(x) \lesssim^n \tau_{\max} \quad (5.20)$$

$$g_2(x) \equiv \sigma(x) \lesssim^n \sigma_{\max} \quad (5.21)$$

$$g_3(x) \equiv x_1 - x_4 \leq 0 \quad (5.22)$$

$$g_4(x) \equiv 0.10471x_1^2x_2 + 0.04811x_3x_4(14 + x_2) - 5 \leq 0 \quad (5.23)$$

$$g_5(x) \equiv 0.125 - x_1 \leq 0 \quad (5.24)$$

$$g_6(x) \equiv \delta(x) \lesssim^n \delta_{\max} \quad (5.25)$$

$$g_7(x) \equiv P - P_c(x) \leq 0 \quad (5.26)$$

$$x_1, x_2, x_3, x_4 \in [0, 1] \quad (5.27)$$

Where all the parameters have their usual meaning as stated in sect.5.1.2 .Here constraint goals are characterized by Neutrosophic Sets

$$\tilde{\tau}_{\max}^n = \left( \tau_{\max}(x_1, x_2), T_{\tilde{\tau}_{\max}^n}(\tau_{\max}(x_1, x_2)), I_{\tilde{\tau}_{\max}^n}(\tau_{\max}(x_1, x_2)), F_{\tilde{\tau}_{\max}^n}(\tau_{\max}(x_1, x_2)) \right) \quad (5.28)$$

with  $T_{\tilde{\tau}_{\max}^n}(\tau_{\max}(x_1, x_2))$ ,  $I_{\tilde{\tau}_{\max}^n}(\tau_{\max}(x_1, x_2))$ ,  $F_{\tilde{\tau}_{\max}^n}(\tau_{\max}(x_1, x_2))$  as the degree of truth, indeterminacy and falsity membership function of Neutrosophic set  $\tilde{\tau}_{\max}^n$ ;

$$\tilde{\sigma}_{\max}^n = \left( \sigma_{\max}(x_3, x_4), T_{\tilde{\sigma}_{\max}^n}(\sigma_{\max}(x_3, x_4)), I_{\tilde{\sigma}_{\max}^n}(\sigma_{\max}(x_3, x_4)), F_{\tilde{\sigma}_{\max}^n}(\sigma_{\max}(x_3, x_4)) \right) \quad (5.29)$$

with  $T_{\tilde{\sigma}_{\max}^n}(\sigma_{\max}(x_3, x_4))$ ,  $I_{\tilde{\sigma}_{\max}^n}(\sigma_{\max}(x_3, x_4))$ ,  $F_{\tilde{\sigma}_{\max}^n}(\sigma_{\max}(x_3, x_4))$  as the degree of truth, indeterminacy and falsity membership function of Neutrosophic set  $\tilde{\sigma}_{\max}^n$ ; and

$$\tilde{\delta}_{\max}^n = \left( \delta_{\max}(x_3, x_4), T_{\tilde{\delta}_{\max}^n}(\delta_{\max}(x_3, x_4)), I_{\tilde{\delta}_{\max}^n}(\delta_{\max}(x_3, x_4)), F_{\tilde{\delta}_{\max}^n}(\delta_{\max}(x_3, x_4)) \right) \quad (5.30)$$

with  $T_{\tilde{\delta}_{\max}^n}(\delta_{\max}(x_3, x_4))$ ,  $I_{\tilde{\delta}_{\max}^n}(\delta_{\max}(x_3, x_4))$ ,  $F_{\tilde{\delta}_{\max}^n}(\delta_{\max}(x_3, x_4))$  as the degree of truth, indeterminacy and falsity membership function of Neutrosophic set  $\tilde{\delta}_{\max}^n$

### 5.1.3 Optimization of WBD in Neutrosophic Environment

To solve the WBD (P5.2) step 1 of sect.1.29 is used and we will get optimum solutions of two sub problem as  $X^1$  and  $X^2$ . After that according to step 2 we find upper and lower bound of membership function of objective function as  $U_{C(X)}^T, U_{C(X)}^I, U_{C(X)}^F$  and  $L_{C(X)}^T, L_{C(X)}^I, L_{C(X)}^F$  where

$$U_{C(X)}^T = \max \{C(X^1), C(X^2)\}, \quad (5.31)$$

$$L_{C(X)}^I = \min \{C(X^1), C(X^2)\}, \quad (5.32)$$

Therefore

$$U_{C(X)}^F = U_{C(X)}^T, L_{C(X)}^F = L_{C(X)}^I + \varepsilon_{C(X)} \text{ where } 0 < \varepsilon_{C(X)} < (U_{C(X)}^T - L_{C(X)}^I) \quad (5.33)$$

$$L_{C(X)}^I = L_{C(X)}^I, U_{C(X)}^I = L_{C(X)}^I + \xi_{C(X)} \text{ where } 0 < \xi_{C(X)} < (U_{C(X)}^T - L_{C(X)}^I) \quad (5.34)$$

for Model-I,II-BL,BN

$$U_{WT}^F = U_{WT}^T = U_{WT}^I$$

$$L_{WT}^F = L_{WT}^I - \varepsilon_{WT} \text{ where } 0 < \varepsilon_{WT} < (U_{WT}^T - L_{WT}^I)$$

$$L_{WT}^I = L_{WT}^I - \xi_{WT} \text{ where } 0 < \xi_{WT} < (U_{WT}^T - L_{WT}^I)$$



Let the linear membership functions for objective be,

$$T_{C(X)}(C(X)) = \begin{cases} 1 & \text{if } C(X) \leq L_{C(X)}^T \\ \left( \frac{U_{C(X)}^T - C(X)}{U_{C(X)}^T - L_{C(X)}^T} \right) & \text{if } L_{C(X)}^T \leq C(X) \leq U_{C(X)}^T \\ 0 & \text{if } C(X) \geq U_{C(X)}^T \end{cases} \quad (5.35)$$

Model-I,II-AL

$$I_{C(X)}(C(X)) = \begin{cases} 1 & \text{if } C(X) \leq L_{WT(A)}^T \\ \left( \frac{(L_{C(X)}^T + \xi_{C(X)}) - C(X)}{\xi_{C(X)}} \right) & \text{if } L_{C(X)}^T \leq C(X) \leq L_{C(X)}^T + \xi_{C(X)} \\ 0 & \text{if } WT(A) \geq L_{C(X)}^T + \xi_{C(X)} \end{cases} \quad (5.36)$$

Model-I,II-BL

$$I_{C(X)}(C(X)) = \begin{cases} 1 & \text{if } C(X) \geq U_{WT(A)}^T \\ \left( \frac{C(X) - (L_{C(X)}^T + \xi_{C(X)})}{U_{WT(A)}^T - L_{WT(A)}^T - \xi_{C(X)}} \right) & \text{if } L_{C(X)}^T + \xi_{C(X)} \leq C(X) \leq U_{WT(A)}^T \\ 0 & \text{if } WT(A) \leq L_{C(X)}^T + \xi_{C(X)} \end{cases} \quad (5.37)$$

$$F_{C(X)}(C(X)) = \begin{cases} 0 & \text{if } C(X) \leq L_{C(X)}^T + \varepsilon_{C(X)} \\ \left( \frac{C(X) - (L_{C(X)}^T + \varepsilon_{C(X)})}{U_{C(X)}^T - L_{C(X)}^T - \varepsilon_{C(X)}} \right) & \text{if } L_{C(X)}^T + \varepsilon_{C(X)} \leq C(X) \leq U_{C(X)}^T \\ 1 & \text{if } C(X) \geq U_{C(X)}^T \end{cases} \quad (5.38)$$

and constraints be,

$$T_{\sigma_i(X)}(\sigma_i(X)) = \begin{cases} 1 & \text{if } \sigma_i(X) \leq L_{\sigma_i}^T \\ \left( \frac{U_{\sigma_i}^T - \sigma_i(X)}{U_{\sigma_i}^T - L_{\sigma_i}^T} \right) & \text{if } L_{\sigma_i}^T \leq \sigma_i(X) \leq U_{\sigma_i}^T \\ 0 & \text{if } \sigma_i(X) \geq U_{\sigma_i}^T \end{cases} \quad (5.39)$$

Model-I,II-AL

$$I_{\sigma_i(X)}(\sigma_i(X)) = \begin{cases} 1 & \text{if } \sigma_i(X) \leq L_{\sigma_i}^T \\ \left( \frac{(L_{\sigma_i}^T + \xi_{\sigma_i(X)}) - \sigma_i(X)}{\xi_{\sigma_i(X)}} \right) & \text{if } L_{\sigma_i}^T \leq \sigma_i(X) \leq L_{\sigma_i}^T + \xi_{\sigma_i(X)} \\ 0 & \text{if } \sigma_i(X) \geq L_{\sigma_i}^T + \xi_{\sigma_i(X)} \end{cases} \quad (5.40)$$

Model-I,II-BL

$$I_{\sigma_i(X)}(\sigma_i(X)) = \begin{cases} 1 & \text{if } \sigma_i(X) \geq U_{\sigma_i}^T \\ \left( \frac{\sigma_i(X) - (L_{\sigma_i}^T + \xi_{\sigma_i(X)})}{U_{\sigma_i}^T - L_{\sigma_i}^T - \xi_{\sigma_i(X)}} \right) & \text{if } L_{\sigma_i}^T + \xi_{\sigma_i(X)} \leq \sigma_i(X) \leq U_{\sigma_i}^T \\ 0 & \text{if } \sigma_i(X) \leq L_{\sigma_i}^T + \xi_{\sigma_i(X)} \end{cases} \quad (5.41)$$

$$F_{\sigma_i(X)}(\sigma_i(X)) = \begin{cases} 0 & \text{if } \sigma_i(X) \leq L_{\sigma_i}^T + \varepsilon_{\sigma_i(X)} \\ \left( \frac{\sigma_i(X) - L_{\sigma_i}^T - \varepsilon_{\sigma_i(X)}}{U_{\sigma_i}^T - L_{\sigma_i}^T - \varepsilon_{\sigma_i(X)}} \right) & \text{if } L_{\sigma_i}^T + \varepsilon_{\sigma_i(X)} \leq \sigma_i(X) \leq U_{\sigma_i}^T \\ 1 & \text{if } \sigma_i(X) \geq U_{\sigma_i}^T \end{cases} \quad (5.42)$$

for  $j = 1, 2, \dots, m$   $0 < \varepsilon_{\sigma_i(X)}, \xi_{\sigma_i(X)} < \sigma_i^0$

Using Smarandache's definition of intersection of neutrosophic sets and decision making criteria NSO problem (P5.2), can be formulated as the following crisp linear programming problem by considering linear membership as follows,

**Model-I-AL**

**(P5.3)**

$$\text{Maximize } (\alpha - \beta + \gamma) \quad (5.43)$$

Such that

$$C(X) + \alpha(U_{C(X)}^T - L_{C(X)}^T) \leq U_{C(X)}^T; \quad (5.44)$$

$$C(X) + \gamma\xi_{C(X)} \leq L_{C(X)}^T + \xi_{C(X)}; \quad (5.45)$$

$$C(X) - \beta(U_{C(X)}^T - L_{C(X)}^T - \varepsilon_{C(X)}) \leq L_{C(X)}^T + \varepsilon_{C(X)}; \quad (5.46)$$

$$\sigma_i(X) + \alpha(U_{\sigma_i(X)}^T - L_{\sigma_i(X)}^T) \leq U_{\sigma_i(X)}^T; \quad (5.47)$$

$$\sigma_i(X) + \gamma \xi_{\sigma_i(X)} \leq U_{\sigma_i(X)}^T + \xi_{\sigma_i(X)}; \quad (5.48)$$

$$\sigma_i(X) - \beta \left( U_{\sigma_i(X)}^T - L_{\sigma_i(X)}^T - \varepsilon_{\sigma_i(X)} \right) \leq L_{\sigma_i(X)}^T + \varepsilon_{\sigma_i(X)}; \quad (5.49)$$

$$\alpha + \beta + \gamma \leq 3; \quad (5.50)$$

$$\alpha \geq \beta; \alpha \geq \gamma; \quad (5.51)$$

$$\alpha, \beta, \gamma \in [0, 1] \quad (5.52)$$

### Model-I-BL

#### (P5.4)

$$\text{Maximize } (\alpha - \beta + \gamma) \quad (5.53)$$

Such that

$$C(X) + \alpha \left( U_{C(X)}^T - L_{C(X)}^T \right) \leq U_{C(X)}^T; \quad (5.54)$$

$$C(X) - \gamma \left( U_{C(X)}^T - L_{C(X)}^T - \xi_{C(X)} \right) \geq L_{C(X)}^T + \xi_{C(X)}; \quad (5.55)$$

$$C(X) - \beta \left( U_{C(X)}^T - L_{C(X)}^T - \varepsilon_{C(X)} \right) \leq L_{C(X)}^T + \varepsilon_{C(X)}; \quad (5.56)$$

$$\sigma_i(X) + \alpha \left( U_{\sigma_i(X)}^T - L_{\sigma_i(X)}^T \right) \leq U_{\sigma_i(X)}^T; \quad (5.57)$$

$$\sigma_i(X) - \gamma \left( U_{\sigma_i(X)}^T - L_{\sigma_i(X)}^T - \xi_{\sigma_i(X)} \right) \leq L_{\sigma_i(X)}^T + \xi_{\sigma_i(X)}; \quad (5.46)$$

$$\sigma_i(X) - \beta \left( U_{\sigma_i(X)}^T - L_{\sigma_i(X)}^T - \varepsilon_{\sigma_i(X)} \right) \leq L_{\sigma_i(X)}^T + \varepsilon_{\sigma_i(X)}; \quad (5.58)$$

$$\alpha + \beta + \gamma \leq 3; \quad (5.59)$$

$$\alpha \geq \beta; \alpha \geq \gamma; \quad (5.60)$$

$$\alpha, \beta, \gamma \in [0, 1]$$

Here Model-I-AL and Model-I-BL stand for the Neutrosophic Optimization algorithm with indeterminacy membership function of decreasing sense and increasing sense respectively.

#### (P5.5)

**Model-II-AL**

$$\text{Maximize } (\alpha - \beta - \gamma) \quad (5.61)$$

Subject to

$$C(X) + \alpha(U_{C(X)}^T - L_{C(X)}^T) \leq U_{C(X)}^T; \quad (5.62)$$

$$C(X) + \gamma \xi_{C(X)} \geq L_{C(X)}^T + \xi_{C(X)}; \quad (5.63)$$

$$C(X) - \beta(U_{C(X)}^T - L_{C(X)}^T - \varepsilon_{C(X)}) \leq L_{C(X)}^T + \varepsilon_{C(X)}; \quad (5.64)$$

$$\sigma_i(X) + \alpha(U_{\sigma_i(X)}^T - L_{\sigma_i(X)}^T) \leq U_{\sigma_i(X)}^T; \quad (5.65)$$

$$\sigma_i(X) - \gamma \xi_{\sigma_i(X)} \geq L_{\sigma_i(X)}^T + \xi_{\sigma_i(X)}; \quad (5.66)$$

$$\sigma_i(X) - \beta(U_{\sigma_i(X)}^T - L_{\sigma_i(X)}^T - \varepsilon_{\sigma_i(X)}) \leq L_{\sigma_i(X)}^T + \varepsilon_{\sigma_i(X)};$$

(5.67)

$$\alpha + \beta + \gamma \leq 3; \quad (5.68)$$

$$\alpha \geq \beta; \alpha \geq \gamma; \quad (5.69)$$

$$\alpha, \beta, \gamma \in [0, 1] \quad (5.70)$$

**Model-II-BL**

**(P5.6)**

$$\text{Maximize } (\alpha - \beta - \gamma) \quad (5.71)$$

Subject to

$$C(X) + \alpha(U_{C(X)}^T - L_{C(X)}^T) \leq U_{C(X)}^T; \quad (5.72)$$

$$C(X) + \gamma(U_{C(X)}^T - L_{C(X)}^T - \xi_{C(X)}) \leq L_{C(X)}^T + \xi_{C(X)}; \quad (5.73)$$

$$C(X) - \beta(U_{C(X)}^T - L_{C(X)}^T - \varepsilon_{C(X)}) \leq L_{C(X)}^T + \varepsilon_{C(X)}; \quad (5.74)$$

$$\sigma_i(X) + \alpha(U_{\sigma_i(X)}^T - L_{\sigma_i(X)}^T) \leq U_{\sigma_i(X)}^T; \quad (5.75)$$

$$\sigma_i(X) - \gamma(U_{\sigma_i(X)}^T - L_{\sigma_i(X)}^T - \xi_{\sigma_i(X)}) \leq L_{\sigma_i(X)}^T + \xi_{\sigma_i(X)}; \quad (5.76)$$

$$\sigma_i(X) - \beta(U_{\sigma_i(X)}^T - L_{\sigma_i(X)}^T - \varepsilon_{\sigma_i(X)}) \leq L_{\sigma_i(X)}^T + \varepsilon_{\sigma_i(X)}; \quad (5.77)$$

$$\alpha + \beta + \gamma \leq 3; \quad (5.78)$$

$$\alpha \geq \beta; \alpha \geq \gamma; \quad (5.79)$$

$$\alpha, \beta, \gamma \in [0, 1]$$

Here Model-II-AL and Model-II-BL stand for the Neutrosophic Optimization algorithm with indeterminacy membership function of decreasing sense and increasing sense respectively.

All these crisp nonlinear programming problem can be solved by appropriate mathematical algorithm.

## 5.2 Numerical Solution of WBD by Single Objective Neutrosophic Optimization Technique

Input data of welded beam design problem (P5.1) are given in Table 5.1 as follows

**Table 5.1 Input Data for Neutrosophic Model (P5.2)**

Applied load $P$ ( $lb$ )	Beam length beyond weld $L$ ( $in$ )	Young Modulus $E$ ( $psi$ )	Value of $G$ ( $psi$ )	Maximum allowable shear stress $\tau_{max}$ ( $psi$ )	Maximum allowable normal stress $\sigma_{max}$ ( $psi$ )	Maximum allowable deflection $\delta_{max}$ ( $in$ )
6000	14	$3 \times 10^6$	$12 \times 10^6$	13600 with allowable tolerance 50	30000 with allowable tolerance 50	0.25 with allowable tolerance 0.05

**Solution:** According to step 2 of sect. 1.29, we find upper and lower bound of membership function of objective function as  $U_{C(x)}^T, U_{C(x)}^I, U_{C(x)}^F$  and  $L_{C(x)}^T, L_{C(x)}^I, L_{C(x)}^F$  where  $U_{C(x)}^T = 1.861642 = U_{C(x)}^F, L_{C(x)}^T = 1.858613 = L_{C(x)}^I, L_{C(x)}^F = 1.858613 + \varepsilon_{C(x)}$ , with  $0 < \varepsilon_{C(x)} < .003029$ ; and  $U_{C(x)}^I = L_{C(x)}^T + \xi_{C(x)}$  with  $0 < \xi_{C(x)} < .003029$

Now using the bounds we calculate the membership functions for objective as follows

$$T_{C(x)}(C(X)) = \begin{cases} 1 & \text{if } C(X) \leq 1.858613 \\ \left( \frac{1.861642 - C(X)}{.003029} \right) & \text{if } 1.858613 \leq C(X) \leq 1.861642 \\ 0 & \text{if } C(X) \geq 1.861642 \end{cases} \quad (5.80)$$

For Model-I-AL

$$I_{C(x)}(C(X)) = \begin{cases} 1 & \text{if } C(X) \leq 1.858613 \\ \left( \frac{(1.858613 + \xi_{C(x)}) - g(x)}{\xi_{C(x)}} \right) & \text{if } 1.858613 \leq C(X) \leq 1.858613 + \xi_{C(x)} \\ 0 & \text{if } C(X) \geq 1.858613 + \xi_{C(x)} \end{cases} \quad (5.81)$$

For Model-I-BL

$$I_{C(x)}(C(X)) = \begin{cases} 1 & \text{if } C(X) \geq 1.861642 \\ \left( \frac{g(x) - (1.858613 + \xi_{C(x)})}{0.003029 - \xi_{C(x)}} \right) & \text{if } 1.858613 + \xi_{C(x)} \leq C(X) \leq 1.861642 \\ 0 & \text{if } C(X) \leq 1.858613 + \xi_{C(x)} \end{cases} \quad (5.82)$$

$$F_{C(x)}(C(X)) = \begin{cases} 0 & \text{if } C(X) \leq 1.858613 + \varepsilon_{C(x)} \\ \left( \frac{C(X) - 1.858613 - \varepsilon_{C(x)}}{.003029 - \varepsilon_{C(x)}} \right) & \text{if } 1.858613 + \varepsilon_{C(x)} \leq C(X) \leq 1.861642 \\ 1 & \text{if } C(X) \geq 1.861642 \end{cases} \quad (5.83)$$

Similarly the membership functions for shear stress constraint are,

$$T_{g_1(x)}(g_1(x)) = \begin{cases} 1 & \text{if } g_1(x) \leq 13600 \\ \left( \frac{13600 - g_1(x)}{50} \right) & \text{if } 13600 \leq g_1(x) \leq 13650 \\ 0 & \text{if } g_1(x) \geq 13650 \end{cases} \quad (5.84)$$

For Model-I-AL

$$I_{g_1(x)}(g_1(x)) = \begin{cases} 1 & \text{if } g_1(x) \leq 13600 \\ \left( \frac{(13600 + \xi_{g_1(x)}) - g_1(x)}{\xi_{g_1(x)}} \right) & \text{if } 13600 \leq g_1(x) \leq 13600 + \xi_{g_1(x)} \\ 0 & \text{if } g_1(x) \geq 13600 + \xi_{g_1(x)} \end{cases} \quad (5.85)$$

For Model-I-BL

$$I_{g_1(x)}(g_1(x)) = \begin{cases} 1 & \text{if } g_1(x) \geq 13650 \\ \left( \frac{g_1(x) - (13600 + \xi_{g_1(x)})}{50 - \xi_{g_1(x)}} \right) & \text{if } 13600 + \xi_{g_1(x)} \leq g_1(x) \leq 13650 \\ 0 & \text{if } g_1(x) \leq 13600 + \xi_{g_1(x)} \end{cases} \quad (5.86)$$

$$F_{g_1(x)}(g_1(x)) = \begin{cases} 0 & \text{if } g_1(x) \leq 13600 + \varepsilon_{g_1(x)} \\ \left( \frac{g_1(x) - 13600 - \varepsilon_{g_1(x)}}{50 - \varepsilon_{g_1(x)}} \right) & \text{if } 13600 + \varepsilon_{g_1(x)} \leq g_1(x) \leq 13650 \\ 1 & \text{if } g_1(x) \geq 13650 \end{cases} \quad (5.87)$$

where  $0 < \varepsilon_{g_1(x)}, \xi_{g_1(x)} < .003209$

and the membership functions for normal stress constraint are,

$$T_{g_2(x)}(g_2(x)) = \begin{cases} 1 & \text{if } g_2(x) \leq 30000 \\ \left( \frac{30000 - g_2(x)}{50} \right) & \text{if } 30000 \leq g_2(x) \leq 30050 \\ 0 & \text{if } g_2(x) \geq 30050 \end{cases} \quad (5.88)$$

For Model-I-AL

$$I_{g_2(x)}(g_2(x)) = \begin{cases} 1 & \text{if } g_2(x) \leq 30000 \\ \left( \frac{(30000 + \xi_{g_2(x)}) - g_2(x)}{\xi_{g_2(x)}} \right) & \text{if } 30000 \leq g_2(x) \leq 30000 + \xi_{g_2(x)} \\ 0 & \text{if } g_2(x) \geq 30000 + \xi_{g_2(x)} \end{cases} \quad (5.89)$$

For Model-I-BL

$$I_{g_2(x)}(g_2(x)) = \begin{cases} 1 & \text{if } g_2(x) \geq 30050 \\ \left( \frac{g_2(x) - (30000 + \xi_{g_2(x)})}{50 - \xi_{g_2(x)}} \right) & \text{if } 30000 + \xi_{g_2(x)} \leq g_2(x) \leq 30050 \\ 0 & \text{if } g_2(x) \leq 30000 + \xi_{g_2(x)} \end{cases} \quad (5.90)$$

$$F_{g_2(x)}(g_2(x)) = \begin{cases} 0 & \text{if } g_2(x) \leq 30000 + \varepsilon_{g_2(x)} \\ \left( \frac{g_2(x) - 30000 - \varepsilon_{g_2(x)}}{50 - \varepsilon_{g_2(x)}} \right) & \text{if } 30000 + \varepsilon_{g_2(x)} \leq g_2(x) \leq 30050 \\ 1 & \text{if } g_2(x) \geq 30050 \end{cases} \quad (5.91)$$

where  $0 < \varepsilon_{g_2(x)}, \xi_{g_2(x)} < 50$

The membership functions for deflection constraint are,

$$T_{g_6(x)}(g_6(x)) = \begin{cases} 1 & \text{if } g_6(x) \leq 0.25 \\ \left( \frac{0.25 - g_6(x)}{0.05} \right) & \text{if } 0.25 \leq g_6(x) \leq 0.3 \\ 0 & \text{if } g_6(x) \geq 0.3 \end{cases} \quad (5.92)$$

For Model-I-AL



$$I_{g_6(x)}(g_6(x)) = \begin{cases} 1 & \text{if } g_6(x) \leq 0.25 \\ \left( \frac{(0.25 + \xi_{g_6(x)}) - g_6(x)}{\xi_{g_6(x)}} \right) & \text{if } 0.25 \leq g_6(x) \leq 0.25 + \xi_{g_6(x)} \\ 0 & \text{if } g_6(x) \geq 0.25 + \xi_{g_6(x)} \end{cases} \quad (5.93)$$

For Model-I-BL

$$I_{g_6(x)}(g_6(x)) = \begin{cases} 1 & \text{if } g_6(x) \geq 0.3 \\ \left( \frac{g_6(x) - (0.25 + \xi_{g_6(x)})}{0.05 - \xi_{g_6(x)}} \right) & \text{if } 0.25 + \xi_{g_6(x)} \leq g_6(x) \leq 0.3 \\ 0 & \text{if } g_6(x) \leq 0.25 + \xi_{g_6(x)} \end{cases}$$

(5.94)

$$F_{g_6(x)}(g_6(x)) = \begin{cases} 0 & \text{if } g_6(x) \leq 0.25 + \varepsilon_{g_6(x)} \\ \left( \frac{g_6(x) - 0.25 - \varepsilon_{g_6(x)}}{0.05 - \varepsilon_{g_6(x)}} \right) & \text{if } 0.25 + \varepsilon_{g_6(x)} \leq g_6(x) \leq 0.3 \\ 1 & \text{if } g_6(x) \geq 0.3 \end{cases} \quad (5.95)$$

where  $0 < \varepsilon_{g_6(x)}, \xi_{g_6(x)} < .05$

Now, using above mentioned truth, indeterminacy and falsity linear membership function NLP (P5.1) can be solved for Model –I-AL,BL, Model-II-AL,BL, by fuzzy, IF and NSO technique with different values of  $\varepsilon_{C(x)}, \varepsilon_{g_1(x)}, \varepsilon_{g_2(x)}, \varepsilon_{g_6(x)}$  and  $\xi_{C(x)}, \xi_{g_1(x)}, \xi_{g_2(x)}, \xi_{g_6(x)}$ . The optimum height, length, depth, width and cost of welding of welded beam design (P5.1) are given in Table 5.2 and the solutions are compared with other deterministic optimization methods.

**Table 5.2 Comparison of Optimal Solution of Welded Beam Design(P5.1) based on Fuzzy and IF and NSO Technique( Model - I and Model- II) with Different Methods**

Methods	Height $x_1$ (inch)	Length $x_2$ (inch)	Depth $x_3$ (inch)	Width $x_4$ (inch)	Welding cost $C(x)$

					\$
DAVID[6]	0.2434	6.2552	8.2915	0.2444	2.3841
APPROX[6]	0.2444	6.2189	8.2915	0.2444	2.3815
SIMPLEX[6]	0.2792	5.6256	7.7512	0.2796	2.5307
RANDOM[6]	0.4575	4.7313	5.0853	0.66	4.1185
Harmony Search Algorithm[10]	0.2442	6.2231	8.2915	0.2443	2.3807
GA Based Method[9]	0.2489	6.173	8.1789	0.2533	2.4328
GA Based Method[11]	0.2088	3.4205	8.9975	0.21	1.7483
Improved Harmony Search Algorithm[18]	0.20573	3.47049	9.03662	0.20573	1.72485
SiC-PSO[13]	0.205729	3.470488	9.036624	0.205729	1.724852
Mezura [18]	0.244438	6.237967	8.288576	0.244566	2.38119
COPSO[18]	0.205730	3.470489	9.036624	0.205730	1.724852
GA1[18]	0.208800	3.420500	8.997500	0.210000	1.748309
GA2[19]	0.205986	3.471328	9.020224	0.206480	1.728226
EP[20]	0.205700	3.470500	9.036600	0.205700	1.724852
CPSO[21]	0.202369	3.544214	9.048210	0.205723	1.728024
HPSO[15]	0.205730	3.470489	9.036624	0.205730	1.724852
NM-PSO[16]	0.205830	0.3.468338	9.036624	0.205730	1.724717
PSO[24]	0.206412	3.528353	8.988437	0.208052	1.742326
SA[24]	0.165306	5.294754	8.872164	0.217625	1.939196
GL[24]	0.204164	3.565391	9.05924	0.206216	1.7428
Cuckoo [24]	0.20573	3.519497	9.036624	0.20573	1.731527
FF[24]	0.214698	3.655292	8.507188	0.234477	1.864164
FP[24]	0.205729	3.519502	9.036628	0.20573	1.731528
ALO[24]	0.177859	4.393466	9.065462	0.20559	1.796793
GSA[24]	0.219556	4.728342	8.50097	0.271548	2.295076
MVO[24]	0.199033	3.652944	9.114448	0.205478	1.749834
Fuzzy single-objective non- linear programming [28]	.2444216	3.028584	8.283678	0.2444216	1.858613

Intuitionistic Fuzzy single-objective non-linear programming (FSONLP) [28] $\varepsilon_{C(X)} = .0015, \varepsilon_{g_{1(x)}} = 25,$ $\varepsilon_{g_{2(x)}} = 25, \varepsilon_{g_{6(x)}} = .025,$		.2443950	3.034430	8.287578	0.2443950	1.860125
Proposed Neutrosophic optimization(NSO) $\varepsilon_{C(X)} = .0015,$ $\varepsilon_{g_{1(x)}} = 25, \varepsilon_{g_{2(x)}} = 25,$ $\varepsilon_{g_{6(x)}} = .025,$ $\xi_{C(X)} = .0024,$ $\xi_{g_{1(x)}} = 40, \xi_{g_{2(x)}} = 40,$ $\xi_{g_{6(x)}} = .04,$	Model-I-AL	.2443950	3.034430	8.287578	0.2443950	1.860125
	Model-I-BL	NO	FEASIBLE	SOLUTION	FOUND	
	Model-II-AL	.2443950	3.034430	8.287578	0.2443950	1.860125
	Model-II-BL	.7308867	1.840784	2.0	.5078827	1.860419

A detailed comparison has been made among several deterministic optimization methods for optimizing welding cost with imprecise optimization methods such as fuzzy, IF and NSO methods in Table 5.2. It has been observed that fuzzy nonlinear optimization provides better result in comparison with IF and NSO methods. Although it has been seen that cost of welding is minimum other than the method studied in this paper, as far as non-deterministic optimization methods concern ,fuzzy, IF and NSO are providing a valuable result in imprecise environment in this chapter and literature. It has been seen that Improved Harmony Search Algorithm[17],COPSO[17],EP[20],HPSO[15] are providing minimum most cost of welding where all the parameters have been considered as exact in nature . However, it may also be noted that the efficiency of the proposed method depends on the model chosen to a greater extent because it is not always expected that NSO will provide better results over fuzzy and IF optimization . So overall NSO is an efficient method in finding best optimal solution in imprecise environment. It has been studied that same results have been obtained while indeterminant membership tried to be maximize (Model- I) or minimize (Model-II) in NSO for this particular problem.

### **5.3 Conclusion**

In this paper, a single objective NSO algorithm has been developed by defining truth, indeterminacy and falsity membership function which are independent to each other. Using this method firstly optimum height length depth, width and cost of welding have been calculated and finally the results are compared with different deterministic methods. So illustrated example of welded beam design has been provided to illustrate the optimization procedure, effectiveness and advantages of the proposed NSO method. The comparison of NSO technique with other optimization techniques has enhanced the acceptability of proposed method. The proposed procedures has not only validated by the existing methods but also it develops a new direction of optimization theory in imprecise environment which is more realistic.

# CHAPTER 6

---

## Multi-Objective Welded Beam Optimization using Neutrosophic Optimization Technique: A Comparative Study

---

Structural optimization, such as welded beam design optimization is an important notion in civil engineering. Traditionally structural optimization is a well-known concept and in many situations it is treated as single objective form, where the objective is known cost function . The extension of this can be defined as optimization where one or more constraints are simultaneously satisfied next to the minimization of the cost function. This does not always hold well in real world problems where multiple and conflicting objectives frequently exist. In this consequence a methodology known as Multi-Objective Structural Optimization (MOSO) is introduced. Welding, a process of joining metallic parts with the application of heat or pressure or the both, with or without added material, is an economical and efficient method for obtaining permanent joints in the metallic parts. Most important the design of welded beam should preferably be economical and durable one. Since decades, deterministic optimization has been widely used in practice for optimizing welded connection design. These include mathematical optimization algorithms (Ragsdell & Phillips [90]) such as APPROX (Griffith & Stewart's) successive linear approximation, DAVID (Davidon Fletcher Powell with a penalty function), SIMPLEX (Simplex method with a penalty function), and RANDOM (Richardson's random method) algorithms, GA-based methods (Deb [40], Deb [37], Coello [14], Coello [39]), particle swarm optimization (Reddy [59]), harmony search method (Lee & Geem [67]), and Big-Bang Big-Crunch (BB-BC) (O. Hasançebi, [65]) algorithm. SOPT (O. Hasançebi, [55]), subset simulation (Li [69]), improved harmony search algorithm (Mahadavi [72]), etc. All these deterministic optimizations aim to search the optimum solution under given constraints without consideration of uncertainties. So, while a deterministic optimization approach is unable to handle structural performances such as imprecise stresses and deflection etc. due to the presence of uncertainties, to get rid of such problem Fuzzy Set (FS)(Zadeh, [133]), Intuitionistic Fuzzy Set(IFS) (Atanassov,[1]), Neutrosophic Set (NS)(Smarandache,[94]) play great roles. So to deal with different impreciseness such as stresses and deflection with multiple objective ,we have been motivated to incorporate the concept of NS in this problem, and have developed Multi-

Objective Neutrosophic Optimization(MONSO) algorithm to optimize the optimum design. Usually IFS, which is the generalization of FS, considers both truth membership and falsity membership that can handle incomplete information excluding the indeterminate and inconsistent information while NS can quantify indeterminacy explicitly by defining truth, indeterminacy and falsity membership function independently. Therefore in 2010 Wang et.al presented such set as Single Valued Neutrosophic set (SVNS) as it comprised of generalized classic set, FS, interval valued FS, IFS and Para-consistent set.

As application of SVNS optimization method is rare in welded beam design, hence it is used to minimize the cost of welding by considering shear stress, bending stress in the beam, the buckling load on the bar, the deflection of the beam as constraints. Therefore the result has been compared among three cited methods in each of which impreciseness has been considered completely in different way. Moreover using above cited concept, a MONSO algorithm has been developed to optimize three bar truss design (Sarkar et.al [107]), and to optimize riser design problem (Das et.al [25]). However, the factors governing of former constraints are height and length of the welded beam, forces on the beam, moment of load about the centre of gravity of the weld group, polar moment of inertia of the weld group respectively. The second constraint considers forces on the beam, length and size of the weld, depth and width of the welded beam respectively. Third constraint includes height and width of the welded beam. Fourth constraints consist of height, length, depth and width of the welded beam. Lastly fifth constraint includes height of the welded beam. Besides, flexibility has been given in shear stress, bending stress and deflection only, hence all these parameters become imprecise in nature so that it can be considered as NS to form truth, indeterminacy and falsity membership functions. Ultimately, NSO technique has been applied on the basis of the cited membership functions and outcome of such process provides the minimum cost of welding, minimum deflection for nonlinear welded beam design. The comparison of results shows difference between the optimum value when partially unknown information is fully considered or not.

## **6.1 General Form of Multi-Objective Welded Beam Design(MOWBD)**

In sizing optimization problems, the aim is to minimize multi objective function, usually the cost of the structure, deflection under certain behavioural constraints which are displacement or stresses. The design variables are most frequently chosen to be dimensions of the height, length, depth and width of the structures. Due to fabrications limitations the design variables

are not continuous but discrete for belongingness of cross-sections to a certain set. A discrete structural optimization problem can be formulated in the following form

**(P6.1)**

$$\text{Minimize } C(X) \quad (6.1)$$

$$\text{Minimize } \delta(X) \quad (6.2)$$

$$\text{subject to } \sigma_i(X) \leq [\sigma_i(X)], i = 1, 2, \dots, m \quad (6.3)$$

$$X_j \in R^d, \quad j = 1, 2, \dots, n \quad (6.4)$$

where  $C(X)$ ,  $\delta(X)$  and  $\sigma_i(X)$  as represent cost function, deflection and the behavioural constraints respectively whereas  $[\sigma_i(X)]$  denotes the maximum allowable value, 'm' and 'n' are the number of constraints and design variables respectively. A given set of discrete value is expressed by  $R^d$  and in this paper objective functions are taken as

$$C(X) = \sum_{t=1}^T c_t \prod_{n=1}^m x_n^{m_n} \text{ and } \delta(X) \quad (6.5)$$

The constraints are chosen to be stress of structures as follows

$$\sigma_i(A) \lesssim \sigma_i \text{ With allowable tolerance } \sigma_i^0 \text{ for } i = 1, 2, \dots, m \quad (6.6)$$

Where  $c_t$  is the cost coefficient of  $t^{\text{th}}$  side and  $x_n$  is the  $n^{\text{th}}$  design variable respectively,  $m$  is the number of structural element,  $\sigma_i$  and  $\sigma_i^0$  are the  $i^{\text{th}}$  stress, allowable stress respectively.

## 6.2 Solution of Multi-Objective Welded Beam Design (MOWBD)

### Problem by Neutrosophic Optimization (NSO) Technique

To solve the MOSOP (P6.1), step 1 of 1.33 is used. After that according to step to pay off matrix is formulated.

$$\begin{matrix} C(X) & \delta(X) \\ X^1 & \left[ \begin{matrix} C^*(X^1) & \delta(X^1) \end{matrix} \right] \\ X^2 & \left[ \begin{matrix} C(X^2) & \delta^*(X^2) \end{matrix} \right] \end{matrix}$$

According to step-2 the bound of weight objective  $U_{C(X)}^T, L_{C(X)}^T$ ;  $U_{C(X)}^I, L_{C(X)}^I$  and  $U_{C(X)}^F, L_{C(X)}^F$  for truth, indeterminacy and falsity membership function respectively. Then

$$L_{C(X)}^T \leq C(X) \leq U_{C(X)}^T; \quad (6.7)$$

$$L_{C(X)}^I \leq C(X) \leq U_{C(X)}^I; \quad (6.8)$$

$$L_{C(X)}^F \leq C(X) \leq U_{C(X)}^F \quad (6.9)$$

Similarly the bound of deflection objective are  $U_{\delta(X)}^T, L_{\delta(X)}^T; U_{\delta(X)}^I, L_{\delta(X)}^I$  and  $U_{\delta(X)}^F, L_{\delta(X)}^F$  are respectively for truth, indeterminacy and falsity membership function. Then

$$L_{\delta(X)}^T \leq \delta(X) \leq U_{\delta(X)}^T; \quad (6.10)$$

$$L_{\delta(X)}^I \leq \delta(X) \leq U_{\delta(X)}^I; \quad (6.11)$$

$$L_{\delta(X)}^F \leq \delta(X) \leq U_{\delta(X)}^F. \quad (6.12)$$

Where ,for Model-I,II-AL,AN

$$U_{C(X)}^F = U_{C(X)}^T, \quad (6.13)$$

$$L_{C(X)}^F = L_{C(X)}^T + \varepsilon_{C(X)}; \quad (6.14)$$

$$L_{C(X)}^I = L_{C(X)}^T, \quad (6.15)$$

$$U_{C(X)}^I = L_{C(X)}^T + \xi_{C(X)} \quad (6.16)$$

$$0 < \varepsilon_{C(X)}, \xi_{C(X)} < (U_{C(X)}^T - L_{C(X)}^T)$$

for Model-I,II-BL,BN

$$U_{C(X)}^F = U_{C(X)}^T = U_{C(X)}^I$$

$$L_{C(X)}^F = L_{C(X)}^T - \varepsilon_{C(X)} \text{ where } 0 < \varepsilon_{C(X)} < (U_{C(X)}^T - L_{C(X)}^T)$$

$$L_{C(X)}^I = L_{C(X)}^T - \xi_{C(X)} \text{ where } 0 < \xi_{C(X)} < (U_{C(X)}^T - L_{C(X)}^T)$$

And for Model-I,II-AL,AN

$$U_{\delta(X)}^F = U_{\delta(X)}^T, \quad (6.17)$$

$$L_{\delta(X)}^F = L_{\delta(X)}^T + \varepsilon_{\delta(X)}; \quad (6.18)$$

$$L_{\delta(X)}^I = L_{\delta(X)}^T, \quad (6.19)$$

$$U_{\delta(X)}^I = L_{\delta(X)}^T + \xi_{\delta(X)} \quad (6.20)$$

such that



$$0 < \varepsilon_{\delta(x)}, \xi_{\delta(x)} < (U_{\delta(x)}^T - L_{\delta(x)}^T).$$

for Model-I,II-BL,BN

$$U_{\delta(x)}^F = U_{\delta(x)}^T = U_{\delta(x)}^I$$

$$L_{\delta(x)}^F = L_{\delta(x)}^T - \varepsilon_{\delta(x)} \text{ where } 0 < \varepsilon_{\delta(x)} < (U_{\delta(x)}^T - L_{\delta(x)}^T)$$

$$L_{\delta(x)}^I = L_{\delta(x)}^T - \xi_{\delta(x)} \text{ where } 0 < \xi_{\delta(x)} < (U_{\delta(x)}^T - L_{\delta(x)}^T)$$

Therefore the truth, indeterminacy and falsity membership functions for objectives are

$$T_{C(x)}(C(X)) = \begin{cases} 1 & \text{if } C(X) \leq L_{C(x)}^T \\ 1 - \exp\left\{-\psi\left(\frac{U_{C(x)}^T - C(X)}{U_{C(x)}^T - L_{C(x)}^T}\right)\right\} & \text{if } L_{C(x)}^T \leq C(X) \leq U_{C(x)}^T \\ 0 & \text{if } C(X) \geq U_{C(x)}^T \end{cases} \quad (6.21)$$

For Model-I,II-AN

$$I_{C(x)}(C(X)) = \begin{cases} 1 & \text{if } C(X) \leq L_{C(x)}^T \\ \exp\left\{\frac{(L_{C(x)}^T + \xi_{C(x)}) - C(X)}{\xi_{C(x)}}\right\} & \text{if } L_{C(x)}^T \leq C(X) \leq L_{C(x)}^T + \xi_{C(x)} \\ 0 & \text{if } C(X) \geq L_{C(x)}^T + \xi_{C(x)} \end{cases} \quad (6.22)$$

For Model-I,II-BN

$$I_{C(x)}(C(X)) = \begin{cases} 1 & \text{if } C(X) \geq U_{C(x)}^T \\ \exp\left\{\frac{C(X) - (L_{C(x)}^T + \xi_{C(x)})}{U_{C(x)}^T - L_{C(x)}^T - \xi_{C(x)}}\right\} & \text{if } L_{C(x)}^T + \xi_{C(x)} \leq C(X) \leq U_{C(x)}^T \\ 0 & \text{if } C(X) \leq L_{C(x)}^T + \xi_{C(x)} \end{cases} \quad (6.23)$$

$$F_{C(X)}(C(X)) = \begin{cases} 0 & \text{if } C(X) \leq L_{C(X)}^T + \varepsilon_{C(X)} \\ \frac{1}{2} + \frac{1}{2} \tanh \left\{ \left( C(X) - \frac{(U_{C(X)}^T + L_{C(X)}^T) + \varepsilon_{C(X)}}{2} \right) \tau_{C(X)} \right\} & \text{if } L_{C(X)}^T + \varepsilon_{C(X)} \leq C(X) \leq U_{C(X)}^T \\ 1 & \text{if } C(X) \geq U_{C(X)}^T \end{cases} \quad (6.24)$$

where  $0 < \varepsilon_{C(X)}, \xi_{C(X)} < (U_{C(X)}^T - L_{C(X)}^T)$

and

$$T_{\delta(X)}(\delta(X)) = \begin{cases} 1 & \text{if } \delta(X) \leq L_{\delta(X)}^T \\ 1 - \exp \left\{ -\psi \left( \frac{U_{\delta(X)}^T - \delta(X)}{U_{\delta(X)}^T - L_{\delta(X)}^T} \right) \right\} & \text{if } L_{\delta(X)}^T \leq \delta(X) \leq U_{\delta(X)}^T \\ 0 & \text{if } \delta(X) \geq U_{\delta(X)}^T \end{cases} \quad (6.25)$$

Model-I,II-AN

$$I_{\delta(X)}(\delta(X)) = \begin{cases} 1 & \text{if } \delta(X) \leq L_{\delta}^T \\ \exp \left\{ \frac{(L_{\delta(X)}^T + \xi_{\delta(X)}) - \delta(X)}{\xi_{\delta(X)}} \right\} & \text{if } L_{\delta(X)}^T \leq \delta(X) \leq L_{\delta(X)}^T + \xi_{\delta(X)} \\ 0 & \text{if } \delta(X) \geq L_{\delta(X)}^T + \xi_{\delta(X)} \end{cases} \quad (6.26)$$

Model-I,II-AN

Model-I,II-BN

$$I_{\delta(X)}(\delta(X)) = \begin{cases} 1 & \text{if } \delta(X) \geq U_{\delta}^T \\ \exp \left\{ \frac{\delta(X) - (L_{\delta(X)}^T + \xi_{\delta(X)})}{U_{\delta}^T - L_{\delta}^T - \xi_{\delta(X)}} \right\} & \text{if } L_{\delta(X)}^T + \xi_{\delta(X)} \leq \delta(X) \leq U_{\delta}^T \\ 0 & \text{if } \delta(X) \leq L_{\delta(X)}^T + \xi_{\delta(X)} \end{cases} \quad (6.27)$$

$$F_{\delta(X)}(\delta(X)) = \begin{cases} 0 & \text{if } \delta(X) \leq L_{\delta(X)}^T + \varepsilon_{\delta(X)} \\ \frac{1}{2} + \frac{1}{2} \tanh \left\{ \left( \delta(X) - \frac{(U_{\delta(X)}^T + L_{\delta(X)}^T) + \varepsilon_{\delta(X)}}{2} \right) \tau_{\delta(X)} \right\} & \text{if } L_{\delta(X)}^T + \varepsilon_{\delta(X)} \leq \delta(X) \leq U_{\delta(X)}^T \\ 1 & \text{if } \delta(X) \geq U_{\delta(X)}^T \end{cases} \quad (6.28)$$

where  $\psi, \tau$  are non-zero parameters prescribed by the decision maker and for

$$\text{where } 0 < \varepsilon_{\delta(X)}, \xi_{\delta(X)} < (U_{\delta(X)}^T - L_{\delta(X)}^T)$$

According to Smarandache's definition of intersection of neutrosophic sets and decision making criteria NSO algorithm for MOSOP (P6.1) can be formulated as

### Model-I-AN,BN

#### (P6.2)

$$\text{Maximize } (\alpha + \gamma - \beta) \tag{6.29}$$

Subject to

$$T_{C(X)}(C(X)) \geq \alpha; \tag{6.30}$$

$$T_{\delta(X)}(\delta(X)) \geq \alpha; \tag{6.31}$$

$$I_{C(X)}(C(X)) \geq \gamma; \tag{6.32}$$

$$I_{\delta(X)}(\delta(X)) \geq \gamma; \tag{6.33}$$

$$F_{C(X)}(C(X)) \leq \beta; \tag{6.34}$$

$$F_{\delta(X)}(\delta(X)) \leq \beta; \tag{6.35}$$

$$\sigma_i(X) \leq [\sigma_i(X)]; \tag{6.36}$$

$$\alpha + \beta + \gamma \leq 3; \tag{6.37}$$

$$\alpha \geq \beta; \alpha \geq \gamma; \tag{6.38}$$

$$\alpha, \beta, \gamma \in [0, 1], \tag{6.39}$$

$$X^{\min} \leq X \leq X^{\max} \tag{6.40}$$

But in realworld decision making problem a decision maker needs to minimize indeterminacy membership function. So the optimization algorithm problem can be formulated as

### Model-II-AN,BN

#### (P6.3)

$$\text{Maximize } (\alpha - \gamma - \beta) \tag{6.41}$$

Subject to

$$T_{C(X)}(C(X)) \geq \alpha; \tag{6.42}$$

$$T_{\delta(X)}(\delta(X)) \geq \alpha; \tag{6.43}$$

$$I_{C(X)}(C(X)) \leq \gamma; \quad (6.44)$$

$$I_{\delta(X)}(\delta(X)) \leq \gamma; \quad (6.45)$$

$$F_{C(X)}(C(X)) \leq \beta; \quad (6.46)$$

$$F_{\delta(X)}(\delta(X)) \leq \beta; \quad (6.47)$$

$$\sigma_i(X) \leq [\sigma_i(X)]; \quad (6.48)$$

$$\alpha + \beta + \gamma \leq 3; \quad (6.49)$$

$$\alpha \geq \beta; \alpha \geq \gamma; \quad (6.50)$$

$$\alpha, \beta, \gamma \in [0, 1], \quad (6.51)$$

$$X^{\min} \leq X \leq X^{\max}$$

Here Model-IAN and Model-IBN stands for neutrosophic algorithm with indeterminacy membership function as decreasing sense and increasing sense respectively, which is reduced to equivalent non linear programming problem as

#### Model-I-AN

##### (P6.4)

Maximize  $(\theta + \kappa - \eta)$

Such that

$$C(X) + \theta \frac{(U_{C(X)}^T - L_{C(X)}^T)}{\psi} \leq U_{C(X)}^T; \quad (6.52)$$

$$C(X) + \frac{\eta}{\tau_{C(X)}} \leq \frac{U_{C(X)}^T + L_{C(X)}^T + \varepsilon_{C(X)}}{2}; \quad (6.53)$$

$$C(X) + \kappa \xi_{C(X)} \leq L_{C(X)}^T + \xi_{C(X)}; \quad (6.54)$$

$$\delta(X) + \theta \frac{(U_{\delta(X)}^T - L_{\delta(X)}^T)}{\psi} \leq U_{\delta(X)}^T; \quad (6.55)$$

$$\delta(X) + \kappa \xi_{\delta(X)} \leq L_{\delta(X)}^T + \xi_{\delta(X)}; \quad (6.56)$$

$$\delta(X) + \frac{\eta}{\tau_{\delta(X)}} \leq \frac{U_{\delta(X)}^T + L_{\delta(X)}^T + \varepsilon_{\delta(X)}}{2}; \quad (6.57)$$

$$\sigma_i(X) \leq [\sigma_i(X)]; \quad (6.58)$$

$$\theta + \kappa - \eta \leq 3; \quad (6.59)$$

$$\theta \geq \kappa; \theta \geq \eta; \quad (6.60)$$

$$\theta, \kappa, \eta \in [0, 1] \quad (6.61)$$

$$X^{\min} \leq X \leq X^{\max} \quad (6.62)$$

$$\text{where } \theta = -\ln(1 - \alpha); \quad (6.63)$$

$$\psi = 4; \quad (6.64)$$

$$\tau_{C(X)} = \frac{6}{\left(U_{C(X)}^F - L_{C(X)}^F\right)}; \quad (6.65)$$

$$\tau_{\delta(X)} = \frac{6}{\left(U_{\delta(X)}^F - L_{\delta(X)}^F\right)}; \quad (6.66)$$

$$\kappa = \ln \gamma; \quad (6.67)$$

$$\eta = -\tanh^{-1}(2\beta - 1). \quad (6.68)$$

### Model-I-BN

#### (P6.5)

Maximize  $(\theta + \kappa - \eta)$

Such that

$$C(X) + \theta \frac{\left(U_{C(X)}^T - L_{C(X)}^T\right)}{\psi} \leq U_{C(X)}^T; \quad (6.69)$$

$$C(X) + \frac{\eta}{\tau_{C(X)}} \leq \frac{U_{C(X)}^T + L_{C(X)}^T + \varepsilon_{C(X)}}{2}; \quad (6.70)$$

$$C(X) - \kappa \left( U_{C(X)}^T - L_{C(X)}^T - \xi_{C(X)} \right) \geq L_{C(X)}^T + \xi_{C(X)}; \quad (6.71)$$

$$\delta(X) + \theta \frac{\left(U_{\delta(X)}^T - L_{\delta(X)}^T\right)}{\psi} \leq U_{\delta(X)}^T; \quad (6.72)$$

$$\delta(X) - \kappa \left( U_{\delta(X)}^T - L_{\delta(X)}^T - \xi_{\delta(X)} \right) \geq L_{\delta(X)}^T + \xi_{\delta(X)}; \quad (6.73)$$

$$\delta(X) + \frac{\eta}{\tau_{\delta(X)}} \leq \frac{U_{\delta(X)}^T + L_{\delta(X)}^T + \varepsilon_{\delta(X)}}{2}; \quad (6.74)$$

$$\sigma_i(X) \leq [\sigma_i(X)]; \quad (6.75)$$

$$\theta + \kappa - \eta \leq 3; \quad (6.76)$$

$$\theta \geq \kappa; \theta \geq \eta; \quad (6.77)$$

$$\theta, \kappa, \eta \in [0, 1] \quad (6.78)$$

$$X^{\min} \leq X \leq X^{\max} \quad (6.79)$$

$$\text{where } \theta = -\ln(1-\alpha); \quad (6.80)$$

$$\psi = 4; \quad (6.81)$$

$$\tau_{C(X)} = \frac{6}{\left(U_{C(X)}^F - L_{C(X)}^F\right)}; \quad (6.82)$$

$$\tau_{\delta(X)} = \frac{6}{\left(U_{\delta(X)}^F - L_{\delta(X)}^F\right)}; \quad (6.83)$$

$$\kappa = \ln \gamma; \quad (6.84)$$

$$\eta = -\tanh^{-1}(2\beta-1). \quad (6.85)$$

### Model-II-AN

#### (P6.6)

$$\text{Maximize } (\theta - \kappa - \eta) \quad (6.86)$$

Such that

$$C(X) + \theta \frac{\left(U_{C(X)}^T - L_{C(X)}^T\right)}{\psi} \leq U_{C(X)}^T; \quad (6.87)$$

$$C(X) + \frac{\eta}{\tau_{C(X)}} \leq \frac{U_{C(X)}^T + L_{C(X)}^T + \varepsilon_{C(X)}}{2}; \quad (6.88)$$

$$C(X) + \kappa \xi_{C(X)} \geq L_{C(X)}^T + \xi_{C(X)}; \quad (6.89)$$

$$\delta(X) + \theta \frac{\left(U_{\delta(X)}^T - L_{\delta(X)}^T\right)}{\psi} \leq U_{\delta(X)}^T; \quad (6.90)$$

$$\delta(X) + \kappa \xi_{\delta(X)} \geq L_{\delta(X)}^T + \xi_{\delta(X)}; \quad (6.91)$$

$$\delta(X) + \frac{\eta}{\tau_{\delta(X)}} \leq \frac{U_{\delta(X)}^T + L_{\delta(X)}^T + \varepsilon_{\delta(X)}}{2}; \quad (6.92)$$

$$\sigma_i(X) \leq [\sigma_i(X)]; \quad (6.93)$$

$$\theta + \kappa - \eta \leq 3; \quad (6.94)$$

$$\theta \geq \kappa; \theta \geq \eta; \quad (6.95)$$

$$\theta, \kappa, \eta \in [0, 1] \quad (6.96)$$

$$X^{\min} \leq X \leq X^{\max} \quad (6.97)$$

$$\text{where } \theta = -\ln(1-\alpha); \quad (6.98)$$

$$\psi = 4; \quad (6.99)$$

$$\tau_{C(X)} = \frac{6}{\left(U_{C(X)}^F - L_{C(X)}^F\right)}; \quad (6.100)$$

$$\tau_{\delta(X)} = \frac{6}{\left(U_{\delta(X)}^F - L_{\delta(X)}^F\right)}; \quad (6.101)$$

$$\kappa = \ln \gamma; \quad (6.102)$$

$$\eta = -\tanh^{-1}(2\beta - 1). \quad (6.103)$$

### Model-II-BN

#### (P6.7)

$$\text{Maximize } (\theta - \kappa - \eta) \quad (6.104)$$

Such that

$$C(X) + \theta \frac{\left(U_{C(X)}^T - L_{C(X)}^T\right)}{\psi} \leq U_{C(X)}^T; \quad (6.105)$$

$$C(X) + \frac{\eta}{\tau_{C(X)}} \leq \frac{U_{C(X)}^T + L_{C(X)}^T + \varepsilon_{C(X)}}{2}; \quad (6.106)$$

$$C(X) - \kappa \left(U_{C(X)}^T - L_{C(X)}^T - \xi_{C(X)}\right) \leq L_{C(X)}^T + \xi_{C(X)}; \quad (6.107)$$

$$\delta(X) + \theta \frac{\left(U_{\delta(X)}^T - L_{\delta(X)}^T\right)}{\psi} \leq U_{\delta(X)}^T; \quad (6.108)$$

$$\delta(X) - \kappa \left(U_{\delta(X)}^T - L_{\delta(X)}^T - \xi_{\delta(X)}\right) \leq L_{\delta(X)}^T + \xi_{\delta(X)}; \quad (6.109)$$

$$\delta(X) + \frac{\eta}{\tau_{\delta(X)}} \leq \frac{U_{\delta(X)}^T + L_{\delta(X)}^T + \varepsilon_{\delta(X)}}{2}; \quad (6.110)$$

$$\sigma_i(X) \leq [\sigma_i(X)]; \quad (6.111)$$

$$\theta + \kappa - \eta \leq 3; \quad (6.112)$$

$$\theta \geq \kappa; \theta \geq \eta; \quad (6.113)$$

$$\theta, \kappa, \eta \in [0, 1] \quad (6.114)$$

$$X^{\min} \leq X \leq X^{\max} \quad (6.115)$$

$$\text{where } \theta = -\ln(1-\alpha); \quad (6.116)$$

$$\psi = 4; \tag{6.117}$$

$$\tau_{C(x)} = \frac{6}{\left( U_{C(x)}^F - L_{C(x)}^F \right)}; \tag{6.118}$$

$$\tau_{\delta(x)} = \frac{6}{\left( U_{\delta(x)}^F - L_{\delta(x)}^F \right)}; \tag{6.119}$$

$$\kappa = \ln \gamma; \tag{6.120}$$

$$\eta = -\tanh^{-1}(2\beta - 1). \tag{6.121}$$

Solving the above crisp model (P6.4),(P6.5),(P6.6),(P6.7) by an appropriate mathematical programming algorithm we get optimal solution and hence objective functions i.e minimum cost and deflection of the beam will attain optimal solution.

### 6.3 Numerical Solution of Welded Beam Design using Multi-Objective Neutrosophic Optimization Technique

A welded beam (Ragsdell and Philips 1976, Fig.-6.1) has to be designed at minimum cost whose constraints are shear stress in weld ( $\tau$ ), bending stress in the beam ( $\sigma$ ), buckling

load on the bar ( $P$ ), and deflection of the beam ( $\delta$ ). The design variables are 
$$\begin{bmatrix} x_1 \\ x_2 \\ x_3 \\ x_4 \end{bmatrix} = \begin{bmatrix} h \\ l \\ t \\ b \end{bmatrix}$$

where  $h$  is the weld size,  $l$  is the length of the weld,  $t$  is the depth of the welded beam,  $b$  is the width of the welded beam.

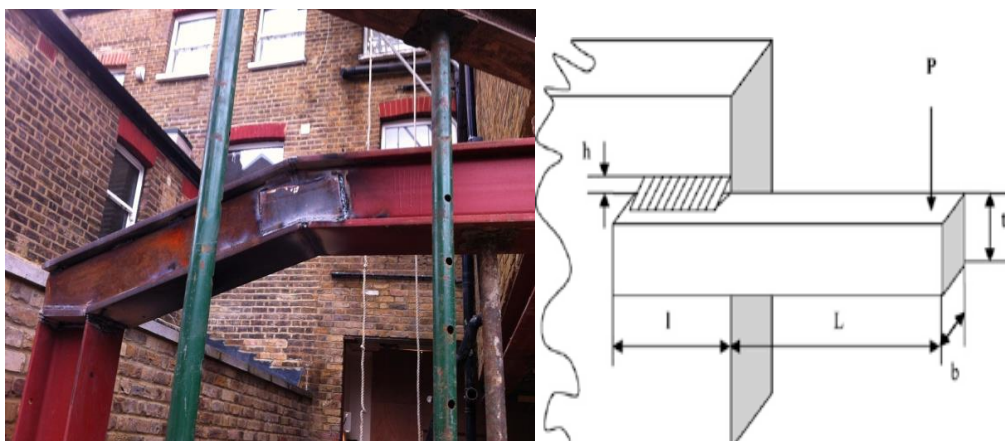

**Fig.-6.1** Design of the Welded Beam(Cracked Beam Onsite Welding, <http://www.allmetalweldingservices.co.uk>, accessed on 19 June 2017)



The multi-objective optimization problem can be stated as follows

**(P6.8)**

$$\text{Minimize } g(x) \equiv 1.10471x_1^2x_2 + 0.04811(14 + x_2)x_3x_4 \quad (6.122)$$

$$\text{Minimize } \delta(x) \equiv \frac{4PL^3}{Ex_4x_3^2}; \quad (6.123)$$

Such that

$$g_1(x) \equiv \tau(x) - \tau_{\max} \leq 0; \quad (6.124)$$

$$g_2(x) \equiv \sigma(x) - \sigma_{\max} \leq 0; \quad (6.125)$$

$$g_3(x) \equiv x_1 - x_4 \leq 0; \quad (6.126)$$

$$g_4(x) \equiv 0.10471x_1^2x_2 + 0.04811x_3x_4(14 + x_2) - 5 \leq 0; \quad (6.127)$$

$$g_5(x) \equiv 0.125 - x_1 \leq 0; \quad (6.128)$$

$$g_6(x) \equiv \delta(x) - \delta_{\max} \leq 0; \quad (6.129)$$

$$g_7(x) \equiv P - P_c(x) \leq 0; \quad (6.130)$$

$$0.1 \leq x_1, x_4, x_2, x_3 \leq 2.0$$

$$\text{where } \tau(x) = \sqrt{\tau_1^2 + 2\tau_1\tau_2 \frac{x_2}{2R} + \tau_2^2}; \quad (6.131)$$

$$\tau_1 = \frac{P}{\sqrt{2x_1x_2}}; \quad (6.132)$$

$$\tau_2 = \frac{MR}{J}; \quad (6.133)$$

$$M = P \left( L + \frac{x_2}{2} \right); \quad (6.134)$$

$$R = \sqrt{\frac{x_2^2}{4} + \left( \frac{x_1 + x_3}{2} \right)^2}; \quad (6.135)$$

$$J = \left\{ \frac{x_1x_2}{\sqrt{2}} \left[ \frac{x_2^2}{12} + \left( \frac{x_1 + x_3}{2} \right)^2 \right] \right\}; \quad (6.136)$$

$$\sigma(x) = \frac{6PL}{x_4x_3^2}; \quad (6.137)$$

$$\delta(x) = \frac{4PL^3}{Ex_4x_3^2}; \quad (6.138)$$

$$P_c(x) = \frac{4.013\sqrt{EGx_3^6x_4^6/36}}{L^2} \left( 1 - \frac{x_3}{2L} \sqrt{\frac{E}{4G}} \right); \quad (6.139)$$

$P$  = Force on beam ;  $L$  = Beam length beyond weld;  $x_1$  = Height of the welded beam;  $x_2$  = Length of the welded beam;  $x_3$  = Depth of the welded beam;  $x_4$  = Width of the welded beam;  $\tau(x)$  = Design shear stress;  $\sigma(x)$  = Design normal stress for beam material;  $M$  = Moment of  $P$  about the centre of gravity of the weld ,  $J$  = Polar moment of inertia of weld group;  $G$  = Shearing modulus of Beam Material;  $E$  = Young modulus;  $\tau_{\max}$  = Design Stress of the weld;  $\sigma_{\max}$  = Design normal stress for the beam material;  $\delta_{\max}$  = Maximum deflection;  $\tau_1$  = Primary stress on weld throat.  $\tau_2$  = Secondary torsional stress on weld. Input data are given in Table 6.1.

**Table 6.1 Input Data for Crisp Model (P6.4)**

Applied load $P$ (lb)	Beam length beyond weld $L$ (in)	Young Modulus $E$ (psi)	Value of $G$ (psi)	Maximum allowable shear stress $\tau_{\max}$ (psi)	Maximum allowable normal stress $\sigma_{\max}$ (psi)
6000	14	$3 \times 10^6$	$12 \times 10^6$	13600	30000

Solution: According to step 2 of 1.33, pay-off matrix is formulated as follows

$$\begin{matrix} & C(X) & \delta(X) \\ X^1 & \begin{bmatrix} 7.700387 & 0.2451363 \end{bmatrix} \\ X^2 & \begin{bmatrix} 11.91672 & 0.1372000 \end{bmatrix} \end{matrix}$$

Here

$$U_{C(x)}^F = U_{C(x)}^T = 11.91672, \quad (6.140)$$

$$L_{C(x)}^F = L_{C(x)}^T + \varepsilon_1 = 7.700387 + \varepsilon_1; \quad (6.141)$$

$$L_{C(x)}^I = L_{C(x)}^T = 7.700387, \quad (6.142)$$

$$U_{C(X)}^I = L_{C(X)}^T + \xi_1 = 7.700387 + \xi_1 \quad (6.143)$$

$$\text{such that } 0 < \varepsilon_1, \xi_1 < (11.91672 - 7.700387); \quad (6.144)$$

$$U_{\delta(X)}^F = U_{\delta(X)}^T = 0.2451363, \quad (6.145)$$

$$L_{\delta(X)}^F = L_{\delta(X)}^T + \varepsilon_2 = .1372000 + \varepsilon_2; \quad (6.146)$$

$$L_{\delta(X)}^I = L_{\delta(X)}^T = 0.1372000, \quad (6.147)$$

$$U_{\delta(X)}^I = L_{\delta(X)}^T + \xi_2 = 0.1372000 + \xi_2 \quad (6.148)$$

$$\text{such that } 0 < \varepsilon_2, \xi_2 < (0.2451363 - 0.1372000)$$

Here truth, indeterminacy, and falsity membership function for objective functions  $C(X), \delta(X)$  are defined as follows

$$T_{C(X)}(C(X)) = \begin{cases} 1 & \text{if } C(X) \leq 7.700387 \\ 1 - \exp\left\{-4\left(\frac{11.91672 - C(X)}{4.216333}\right)\right\} & \text{if } 7.700387 \leq C(X) \leq 11.91672 \\ 0 & \text{if } C(X) \geq 11.91672 \end{cases} \quad (6.149)$$

For Model-I,II-AN

$$I_{C(X)}(C(X)) = \begin{cases} 1 & \text{if } C(X) \leq 7.700387 \\ \exp\left\{\frac{(7.700387 + \xi_1) - C(X)}{\xi_1}\right\} & \text{if } 7.700387 \leq C(X) \leq 7.700387 + \xi_1 \\ 0 & \text{if } C(X) \geq 7.700387 + \xi_1 \end{cases} \quad (6.150)$$

For Model-I,II-BN

$$I_{C(X)}(C(X)) = \begin{cases} 1 & \text{if } C(X) \geq 11.91672 \\ \exp\left\{\frac{C(X) - (7.700387 + \xi_1)}{4.216333 - \xi_1}\right\} & \text{if } 7.700387 + \xi_1 \leq C(X) \leq 11.91672 \\ 0 & \text{if } C(X) \leq 7.700387 + \xi_1 \end{cases} \quad (6.151)$$

$$F_{C(X)}(C(X)) = \begin{cases} 0 & \text{if } C(X) \leq 7.700387 \\ \frac{1}{2} + \frac{1}{2} \tanh\left\{\left(C(X) - \frac{19.617107 + \varepsilon_1}{2}\right) \frac{6}{(4.216333 - \varepsilon_1)}\right\} & \text{if } 7.700387 \leq C(X) \leq 11.91672 \\ 1 & \text{if } C(X) \geq 11.91672 \end{cases} \quad (6.152)$$

$$0 < \varepsilon_1, \xi_1 < 4.216333$$

and

$$T_{\delta(X)}(\delta(X)) = \begin{cases} 1 & \text{if } \delta(X) \leq 0.1372000 \\ 1 - \exp\left\{-4\left(\frac{0.2451363 - \delta(X)}{0.1079363}\right)\right\} & \text{if } 0.1372000 \leq \delta(X) \leq 0.2451363 \\ 0 & \text{if } \delta(X) \geq 0.2451363 \end{cases} \quad (6.153)$$

For Model-I,II-AN

$$I_{\delta(X)}(\delta(X)) = \begin{cases} 1 & \text{if } \delta(X) \leq 0.1372000 \\ \exp\left\{\frac{(0.1372000 + \xi_2) - \delta(X)}{\xi_2}\right\} & \text{if } 0.1372000 \leq \delta(X) \leq 0.1372000 + \xi_2 \\ 0 & \text{if } \delta(X) \geq 0.1372000 + \xi_2 \end{cases} \quad (6.154)$$

For Model-I,II-BN

$$I_{\delta(X)}(\delta(X)) = \begin{cases} 1 & \text{if } \delta(X) \geq 0.2451363 \\ \exp\left\{\frac{\delta(X) - (0.1372000 + \xi_2)}{0.1079363 - \xi_2}\right\} & \text{if } 0.1372000 + \xi_2 \leq \delta(X) \leq 0.2451363 \\ 0 & \text{if } \delta(X) \leq 0.1372000 + \xi_2 \end{cases} \quad (6.155)$$

$$F_{\delta(X)}(\delta(X)) = \begin{cases} 0 & \text{if } \delta(X) \leq 0.1079363 + \varepsilon_2 \\ \frac{1}{2} + \frac{1}{2} \tanh\left\{\left(\delta(X) - \frac{0.3823363 + \varepsilon_2}{2}\right) \frac{6}{0.1079363 - \varepsilon_2}\right\} & \text{if } 0.1079363 + \varepsilon_2 \leq \delta(X) \leq 0.2451363 \\ 1 & \text{if } \delta(X) \geq 0.2451363 \end{cases} \quad (6.156)$$

$$0 < \varepsilon_2, \xi_2 < 0.1079363$$

According to NSO technique the MOSOP (P6.4) can be formulated as

**Model-I-AN**

**(P6.9)**

$$\text{Maximize } (\theta + \kappa - \eta) \quad (6.157)$$

$$1.10471x_1^2x_2 + 0.04811(14 + x_2)x_3x_4 + \frac{4.216333}{4}\theta \leq 11.91672; \quad (6.158)$$

$$1.10471x_1^2x_2 + 0.04811(14 + x_2)x_3x_4 + \frac{\eta(4.216333 - \varepsilon_1)}{6} \leq \frac{(19.617107 + \varepsilon_1)}{2}; \quad (6.159)$$

$$1.10471x_1^2x_2 + 0.04811(14 + x_2)x_3x_4 + \kappa\xi_1 \leq (7.700387 + \xi_1); \quad (6.160)$$

$$\frac{4PL^3}{Ex_4x_3^2} + \frac{0.1079363}{4}\theta \leq 0.2451363; \quad (6.161)$$

$$\frac{4PL^3}{Ex_4x_3^2} + \frac{\eta(0.1079363 - \varepsilon_2)}{6} \leq \frac{(0.3823363 + \varepsilon_2)}{2}; \quad (6.162)$$

$$\frac{4PL^3}{Ex_4x_3^2} + \kappa\xi_2 \leq (0.1372000 + \xi_2); \quad (6.163)$$

$$g_1(x) \equiv \tau(x) - \tau_{\max} \leq 0; \quad (6.164)$$

$$g_2(x) \equiv \sigma(x) - \sigma_{\max} \leq 0; \quad (6.165)$$

$$g_3(x) \equiv x_1 - x_4 \leq 0; \quad (6.166)$$

$$g_5(x) \equiv 0.125 - x_1 \leq 0; \quad (6.167)$$

$$g_6(x) \equiv \delta(x) - \delta_{\max} \leq 0; \quad (6.168)$$

$$g_7(x) \equiv P - P_c(x) \leq 0; \quad (6.169)$$

$$0.1 \leq x_1, x_4, x_2, x_3 \leq 2.0 \quad (6.170)$$

$$\theta + \kappa + \eta \leq 3; \theta \geq \kappa; \theta \geq \eta \quad (6.171)$$

$$\theta = -\ln(1 - \alpha); \quad (6.172)$$

$$\psi = 4; \quad (6.173)$$

$$\tau_{c(x)} = \frac{6}{\left(U_{c(x)}^F - L_{c(x)}^F\right)}; \quad (6.174)$$

$$\tau_{\delta(x)} = \frac{6}{\left(U_{\delta(x)}^F - L_{\delta(x)}^F\right)}; \quad (6.175)$$

$$\kappa = \ln \gamma; \quad (6.176)$$

$$\eta = -\tanh^{-1}(2\beta - 1). \quad (6.177)$$

$$\tau(x) = \sqrt{\tau_1^2 + 2\tau_1\tau_2 \frac{x_2}{2R} + \tau_2^2}; \quad (6.178)$$

$$\tau_1 = \frac{P}{\sqrt{2}x_1x_2}; \quad (6.179)$$

$$\tau_2 = \frac{MR}{J}; \quad (6.180)$$

$$M = P\left(L + \frac{x_2}{2}\right); \quad (6.181)$$

$$R = \sqrt{\frac{x_2^2}{4} + \left(\frac{x_1 + x_3}{2}\right)^2}; \quad (6.182)$$

$$J = \left\{ \frac{x_1x_2}{\sqrt{2}} \left[ \frac{x_2^2}{12} + \left(\frac{x_1 + x_3}{2}\right)^2 \right] \right\}; \quad (6.183)$$

$$\sigma(x) = \frac{6PL}{x_4 x_3^2}; \quad (6.184)$$

$$\delta(x) = \frac{4PL^3}{Ex_4 x_3^2}; \quad (6.185)$$

$$P_c(x) = \frac{4.013\sqrt{EGx_3^6 x_4^6 / 36}}{L^2} \left(1 - \frac{x_3}{2L} \sqrt{\frac{E}{4G}}\right); \quad (6.186)$$

### Model-I-BN

#### (P6.10)

$$\text{Maximize } (\theta + \kappa - \eta) \quad (6.187)$$

$$1.10471x_1^2 x_2 + 0.04811(14 + x_2)x_3 x_4 + \frac{4.216333}{4} \theta \leq 11.91672; \quad (6.188)$$

$$1.10471x_1^2 x_2 + 0.04811(14 + x_2)x_3 x_4 + \frac{\eta(4.216333 - \varepsilon_1)}{6} \leq \frac{(19.617107 + \varepsilon_1)}{2}; \quad (6.189)$$

$$1.10471x_1^2 x_2 + 0.04811(14 + x_2)x_3 x_4 + \kappa(4.216333 - \xi_1) \geq (7.700387 + \xi_1); \quad (6.190)$$

$$\frac{4PL^3}{Ex_4 x_3^2} + \frac{0.1079363}{4} \theta \leq 0.2451363; \quad (6.191)$$

$$\frac{4PL^3}{Ex_4 x_3^2} + \frac{\eta(0.1079363 - \varepsilon_2)}{6} \leq \frac{(0.3823363 + \varepsilon_2)}{2}; \quad (6.192)$$

$$\frac{4PL^3}{Ex_4 x_3^2} + \kappa(0.1079363 - \xi_2) \geq (0.1372000 + \xi_2); \quad (6.193)$$

$$g_1(x) \equiv \tau(x) - \tau_{\max} \leq 0; \quad (6.194)$$

$$g_2(x) \equiv \sigma(x) - \sigma_{\max} \leq 0; \quad (6.195)$$

$$g_3(x) \equiv x_1 - x_4 \leq 0; \quad (6.196)$$

$$g_5(x) \equiv 0.125 - x_1 \leq 0; \quad (6.197)$$

$$g_6(x) \equiv \delta(x) - \delta_{\max} \leq 0; \quad (6.198)$$

$$g_7(x) \equiv P - P_c(x) \leq 0; \quad (6.199)$$

$$0.1 \leq x_1, x_4, x_2, x_3 \leq 2.0 \quad (6.200)$$

$$\theta + \kappa + \eta \leq 3; \theta \geq \kappa; \theta \geq \eta \quad (6.201)$$

$$\theta = -\ln(1 - \alpha); \quad (6.202)$$

$$\psi = 4; \quad (6.203)$$

$$\tau_{C(x)} = \frac{6}{\left(U_{C(x)}^F - L_{C(x)}^F\right)}; \quad (6.204)$$

$$\tau_{\delta(x)} = \frac{6}{\left(U_{\delta(x)}^F - L_{\delta(x)}^F\right)}; \quad (6.205)$$

$$\kappa = \ln \gamma; \quad (6.206)$$

$$\eta = -\tanh^{-1}(2\beta - 1). \quad (6.207)$$

$$\tau(x) = \sqrt{\tau_1^2 + 2\tau_1\tau_2 \frac{x_2}{2R} + \tau_2^2}; \quad (6.208)$$

$$\tau_1 = \frac{P}{\sqrt{2x_1x_2}}; \quad (6.209)$$

$$\tau_2 = \frac{MR}{J}; \quad (6.210)$$

$$M = P\left(L + \frac{x_2}{2}\right); \quad (6.211)$$

$$R = \sqrt{\frac{x_2^2}{4} + \left(\frac{x_1 + x_3}{2}\right)^2}; \quad (6.212)$$

$$J = \left\{ \frac{x_1x_2}{\sqrt{2}} \left[ \frac{x_2^2}{12} + \left(\frac{x_1 + x_3}{2}\right)^2 \right] \right\}; \quad (6.213)$$

$$\sigma(x) = \frac{6PL}{x_4x_3^2}; \quad (6.214)$$

$$\delta(x) = \frac{4PL^3}{Ex_4x_3^2}; \quad (6.215)$$

$$P_C(x) = \frac{4.013\sqrt{EGx_3^6x_4^6/36}}{L^2} \left(1 - \frac{x_3}{2L}\sqrt{\frac{E}{4G}}\right); \quad (6.216)$$

## Model-II-AN

### (P6.11)

$$\text{Maximize } (\theta - \kappa - \eta) \quad (6.217)$$

$$1.10471x_1^2x_2 + 0.04811(14 + x_2)x_3x_4 + \frac{4.216333}{4}\theta \leq 11.91672; \quad (6.218)$$

$$1.10471x_1^2x_2 + 0.04811(14 + x_2)x_3x_4 + \frac{\eta(4.216333 - \varepsilon_1)}{6} \leq \frac{(19.617107 + \varepsilon_1)}{2}; \quad (6.219)$$

$$1.10471x_1^2x_2 + 0.04811(14 + x_2)x_3x_4 + \kappa\xi_1 \geq (7.700387 + \xi_1); \quad (6.220)$$

$$\frac{4PL^3}{Ex_4x_3^2} + \frac{0.1079363}{4}\theta \leq 0.2451363; \quad (6.221)$$

$$\frac{4PL^3}{Ex_4x_3^2} + \frac{\eta(0.1079363 - \varepsilon_2)}{6} \leq \frac{(0.3823363 + \varepsilon_2)}{2}; \quad (6.222)$$

$$\frac{4PL^3}{Ex_4x_3^2} + \kappa\xi_2 \geq (0.1372000 + \xi_2); \quad (6.223)$$

$$g_1(x) \equiv \tau(x) - \tau_{\max} \leq 0; \quad (6.224)$$

$$g_2(x) \equiv \sigma(x) - \sigma_{\max} \leq 0; \quad (6.225)$$

$$g_3(x) \equiv x_1 - x_4 \leq 0; \quad (6.226)$$

$$g_5(x) \equiv 0.125 - x_1 \leq 0; \quad (6.227)$$

$$g_6(x) \equiv \delta(x) - \delta_{\max} \leq 0; \quad (6.228)$$

$$g_7(x) \equiv P - P_C(x) \leq 0; \quad (6.229)$$

$$0.1 \leq x_1, x_4, x_2, x_3 \leq 2.0 \quad (6.230)$$

$$\theta + \kappa + \eta \leq 3; \theta \geq \kappa; \theta \geq \eta \quad (6.231)$$

$$\theta = -\ln(1 - \alpha); \quad (6.232)$$

$$\psi = 4; \quad (6.233)$$

$$\tau_{C(x)} = \frac{6}{\left(U_{C(x)}^F - L_{C(x)}^F\right)}; \quad (6.234)$$

$$\tau_{\delta(x)} = \frac{6}{\left(U_{\delta(x)}^F - L_{\delta(x)}^F\right)}; \quad (6.235)$$

$$\kappa = \ln \gamma; \quad (6.236)$$

$$\eta = -\tanh^{-1}(2\beta - 1). \quad (6.237)$$

$$\tau(x) = \sqrt{\tau_1^2 + 2\tau_1\tau_2 \frac{x_2}{2R} + \tau_2^2}; \quad (6.238)$$

$$\tau_1 = \frac{P}{\sqrt{2}x_1x_2}; \quad (6.239)$$

$$\tau_2 = \frac{MR}{J}; \quad (6.240)$$

$$M = P\left(L + \frac{x_2}{2}\right); \quad (6.241)$$



$$R = \sqrt{\frac{x_2^2}{4} + \left(\frac{x_1 + x_3}{2}\right)^2}; \quad (6.242)$$

$$J = \left\{ \frac{x_1 x_2}{\sqrt{2}} \left[ \frac{x_2^2}{12} + \left(\frac{x_1 + x_3}{2}\right)^2 \right] \right\}; \quad (6.243)$$

$$\sigma(x) = \frac{6PL}{x_4 x_3^2}; \quad (6.244)$$

$$\delta(x) = \frac{4PL^3}{Ex_4 x_3^2}; \quad (6.245)$$

$$P_c(x) = \frac{4.013 \sqrt{EGx_3^6 x_4^6 / 36}}{L^2} \left( 1 - \frac{x_3}{2L} \sqrt{\frac{E}{4G}} \right); \quad (6.246)$$

### Model-II-BN

#### (P6.12)

$$\text{Maximize } (\theta - \kappa - \eta) \quad (6.247)$$

$$1.10471x_1^2 x_2 + 0.04811(14 + x_2)x_3 x_4 + \frac{4.216333}{4} \theta \leq 11.91672; \quad (6.248)$$

$$1.10471x_1^2 x_2 + 0.04811(14 + x_2)x_3 x_4 + \frac{\eta(4.216333 - \varepsilon_1)}{6} \leq \frac{(19.617107 + \varepsilon_1)}{2}; \quad (6.249)$$

$$1.10471x_1^2 x_2 + 0.04811(14 + x_2)x_3 x_4 + \kappa(4.216333 - \xi_1) \leq (7.700387 + \xi_1); \quad (6.250)$$

$$\frac{4PL^3}{Ex_4 x_3^2} + \frac{0.1079363}{4} \theta \leq 0.2451363; \quad (6.251)$$

$$\frac{4PL^3}{Ex_4 x_3^2} + \frac{\eta(0.1079363 - \varepsilon_2)}{6} \leq \frac{(0.3823363 + \varepsilon_2)}{2}; \quad (6.252)$$

$$\frac{4PL^3}{Ex_4 x_3^2} + \kappa(0.1079363 - \xi_2) \leq (0.1372000 + \xi_2); \quad (6.253)$$

$$g_1(x) \equiv \tau(x) - \tau_{\max} \leq 0; \quad (6.254)$$

$$g_2(x) \equiv \sigma(x) - \sigma_{\max} \leq 0; \quad (6.255)$$

$$g_3(x) \equiv x_1 - x_4 \leq 0; \quad (6.256)$$

$$g_5(x) \equiv 0.125 - x_1 \leq 0; \quad (6.257)$$

$$g_6(x) \equiv \delta(x) - \delta_{\max} \leq 0; \quad (6.258)$$

$$g_7(x) \equiv P - P_c(x) \leq 0; \quad (6.259)$$

$$0.1 \leq x_1, x_4, x_2, x_3 \leq 2.0 \quad (6.260)$$

$$\theta + \kappa + \eta \leq 3; \theta \geq \kappa; \theta \geq \eta \quad (6.261)$$

$$\theta = -\ln(1 - \alpha); \quad (6.262)$$

$$\psi = 4; \quad (6.263)$$

$$\tau_{C(x)} = \frac{6}{\left(U_{C(x)}^F - L_{C(x)}^F\right)}; \quad (6.264)$$

$$\tau_{\delta(x)} = \frac{6}{\left(U_{\delta(x)}^F - L_{\delta(x)}^F\right)}; \quad (6.265)$$

$$\kappa = \ln \gamma; \quad (6.266)$$

$$\eta = -\tanh^{-1}(2\beta - 1). \quad (6.267)$$

$$\tau(x) = \sqrt{\tau_1^2 + 2\tau_1\tau_2 \frac{x_2}{2R} + \tau_2^2}; \quad (6.268)$$

$$\tau_1 = \frac{P}{\sqrt{2x_1x_2}}; \quad (6.269)$$

$$\tau_2 = \frac{MR}{J}; \quad (6.270)$$

$$M = P\left(L + \frac{x_2}{2}\right); \quad (6.271)$$

$$R = \sqrt{\frac{x_2^2}{4} + \left(\frac{x_1 + x_3}{2}\right)^2}; \quad (6.272)$$

$$J = \left\{ \frac{x_1x_2}{\sqrt{2}} \left[ \frac{x_2^2}{12} + \left(\frac{x_1 + x_3}{2}\right)^2 \right] \right\}; \quad (6.273)$$

$$\sigma(x) = \frac{6PL}{x_4x_3^2}; \quad (6.274)$$

$$\delta(x) = \frac{4PL^3}{Ex_4x_3^2}; \quad (6.275)$$

$$P_C(x) = \frac{4.013\sqrt{EGx_3^6x_4^6/36}}{L^2} \left(1 - \frac{x_3}{2L} \sqrt{\frac{E}{4G}}\right); \quad (6.276)$$

Now , using above mentioned truth, indeterminacy and falsity membership function NLP (P6.9) ,(P6.10),(P6.11),(P6.12)can be solved by NSO technique for different values of  $\varepsilon_{g(x)}$ ,  $\varepsilon_{\delta(x)}$  and  $\xi_{g(x)}$ ,  $\xi_{\delta(x)}$ . The optimum solution of MOSOP(P6.8) is given in Table 6.2 .

**Table 6.2 Comparison of Optimal Solution of MOSOP (P6.7) based on Different Methods**

Methods	$x_1$ (inch)	$x_2$ (inch)	$x_3$ (inch)	$x_4$ (inch)	$C(X)$	$\delta(X)$
Fuzzy single-objective non-linear programming (FSONLP)	1.298580	0.9727729	1.692776	1.298580	3.395620	0.2456363
Intuitionistic Fuzzy single-objective non-linear programming (IFSONLP) $\varepsilon_{g(x)} = 0.42, \varepsilon_{\delta(x)} = 0.01,$	1.298580	0.9727730	1.692776	1.298580	3.395620	0.2352203
Neutrosophic optimization(NSO) $\varepsilon_{g(x)} = 0.42, \xi_{g(x)} = 0.42,$ $\varepsilon_{\delta(x)} = 0.01, \xi_{\delta(x)} = 0.01,$ Model-I-AN	1.957009	1.240976	2	1.957009	8.120387	0.1402140
Neutrosophic optimization(NSO) $\varepsilon_{g(x)} = 0.42, \xi_{g(x)} = 0.42,$ $\varepsilon_{\delta(x)} = 0.01, \xi_{\delta(x)} = 0.01,$ Model-I-BN	NO	FEASIBLE	SOLUTION	FOUND		
Neutrosophic optimization(NSO) $\varepsilon_{g(x)} = 0.42, \xi_{g(x)} = 0.42,$ $\varepsilon_{\delta(x)} = 0.01, \xi_{\delta(x)} = 0.01,$ Model-II-AN	2	1.588365	2	2	10.01855	0.1961680
Neutrosophic optimization(NSO) $\varepsilon_{g(x)} = 0.42, \xi_{g(x)} = 0.42,$ $\varepsilon_{\delta(x)} = 0.01, \xi_{\delta(x)} = 0.01,$ Model-II-BN	1.940309	1.246993	2	2	8.120387	0.1472

A detailed comparison has been made among the minimum length, depth, height and width of the weld, welding cost and deflection while they have been compared among fuzzy, intuitionistic, NSO technique in perspective of welded beam design in Table 6.2. It has been observed that IF nonlinear optimization provides better result in comparison with other mentioned method in this study. However, it may also be noted that the efficiency of the proposed method depends on the model chosen to a greater extent. In the present study it has also been investigated that that cost of welding is maximum and deflection is minimum in NSO technique compared to the other method investigated.

## 6.4 Conclusion

In this chapter, a multi objective NSO algorithm has been developed by defining truth, indeterminacy and falsity membership function which are independent to each other. It has been shown that the developed algorithm can be applied to optimize a multi objective nonlinear structural design. Simulation example, i.e. welded beam design has been provided to illustrate the optimization procedure, effectiveness and advantages of the proposed NSO method. The extension of the proposed optimization can be NSO by using ranking method of neutrosophic numbers, considered for height, length, depth and width of weld and applied load as further topics of interest.

# CHAPTER 7

---

## Multi-Objective Welded Beam Optimization using Neutrosophic Goal Programming Technique

---

With ever increasing demand for both high production rates and high precision, fully mechanized or automated welding processes have taken a prominent place in the welding field. Welding is the process of joining together two pieces of metal so that bonding takes place at their original boundary surfaces. When two parts are to be joined with or without added metal for formation of metallic bond, they are melted together by heat or pressure or by both. The welding process is divided into two major categories: Plastic Welding or Pressure Welding and Fusion Welding or Non-Pressure Welding. However, above all the design of welded beam should preferably be economical and durable one. Since decades, deterministic optimization has been widely used in practice for optimizing welded connection design. These include mathematical optimization algorithms (Ragsdell & Phillips [90]) such as APPROX (Griffith & Stewart's) successive linear approximation, DAVID (Davidon Fletcher Powell with a penalty function), SIMPLEX (Simplex method with a penalty function), and RANDOM (Richardson's random method) algorithms, GA-based methods (Deb [40], Deb [37], Coello [14], Coello [39]), particle swarm optimization (Reddy [59]), harmony search method (Lee & Geem [67]), and Big-Bang Big-Crunch (BB-BC) (O. Hasançebi, [65]) algorithm. SOPT (O. Hasançebi, [55]), subset simulation (Li [73]), improved harmony search algorithm (Mahadavi [72]), were other methods used to solve this problem. Recently a robust and reliable  $H_\infty$  static output feedback (SOF) control for nonlinear systems (Yanling Wei 2016[128]) and for continuous-time nonlinear stochastic systems (Yanling Wei [29]) with actuator fault in a descriptor system framework have been studied. All these deterministic optimizations aim to search the optimum solution under given constraints without consideration of uncertainties. So, while a deterministic optimization approach is unable to handle structural performances such as imprecise stresses and deflection etc. due to the presence of uncertainties, to get rid of such problem Fuzzy Set (FS)(Zadeh, [133]), Intuitionistic Fuzzy Set (IFS)(Atanassov,[1]), Neutrosophic Set (NS) (Smarandache,[94]) play great roles. Traditionally structural design optimization is a well-known concept and in many situations it is treated as single objective form, where the

objective is known the weight or cost function. The extension of this is the optimization where one or more constraints are simultaneously satisfied next to the minimization of the weight or cost function. This does not always hold good in real world problems where multiple and conflicting objectives frequently exist. In this consequence a methodology known as multi-objective optimization is introduced. So to deal with different impreciseness such as stresses and deflection with multiple objective, we have been motivated to incorporate the concept of NS in this problem, and have developed Multi-Objective Neutrosophic Optimization(MONSO) algorithm to optimize the optimum design. Usually IFS, which is the generalization of FS, considers both truth membership and falsity membership that can handle incomplete information excluding the indeterminate and inconsistent information while NS can quantify indeterminacy explicitly by defining truth, indeterminacy and falsity membership function independently. Therefore, in 2010 Wang et.al presented such set as Single Valued Neutrosophic Set (SVNS) as it comprised of generalized classic set, FS, interval valued FS, IFS and Para-consistent set. As application of SVNS optimization method, it is rare in welded beam design; hence it is used to minimize the cost of welding by considering shear stress, bending stress in the beam, the buckling load on the bar, the deflection of the beam as constraints. Moreover using above cited concept, a MONSO algorithm has been developed to optimize three bar truss design (Sarkar [107]), and to optimize riser design problem (Das [25]). In early 1961 Charnes and Cooper[24] first introduced Goal programming problem for a linear model. Usually conflicting goal are presented in a multi-objective goal programming problem. Actually objective goals of existing structural model are considered to be deterministic and a fixed quantity. In a situation, the decision maker can be doubtful with regard to accomplishment of the goal. The DM may include the idea of truth, indeterminacy and falsity bound on objectives goal. The goal may have a target value with degree of truth, indeterminacy as well as degree of falsity. Precisely, we can say a human being can express degree of truth membership of a given element in a FS, truth and falsity membership in a IFS, but very often does not express the corresponding degree of indeterminacy membership as complement to truth and falsity membership which are independent. This fact seems to take the objective goal as a NS. Dey et al[41]. used intuitionistic goal programming on nonlinear structural model.

This is the first time Neutrosophic Goal Programming (NGP) technique is in application to multi-objective welded beam design. The present study investigates computational algorithm for solving multi-objective welded beam problem by single valued generalized NGP technique. The results are compared numerically for different aggregation method of NGP

technique. From our numerical result, it has been seen that the best result obtained for geometric aggregation method for NGP technique in the perspective of structural optimization technique.

## 7.1 General Formulation of Multi-objective Welded Beam Design

In sizing optimization problems, the aim is to minimize multi objective function, usually the cost of the structure, deflection under certain behavioural constraints which are displacement or stresses. The design variables are most frequently chosen to be dimensions of the height, length, depth and width of the structures. Due to fabrications limitations the design variables are not continuous but discrete for belongingness of cross-sections to a certain set. A discrete structural optimization problem can be formulated in the following form

**(P7.1)**

$$\text{Minimize } C(X) \quad (7.1)$$

$$\text{Minimize } \delta(X) \quad (7.2)$$

$$\text{subject to } \sigma_i(X) \leq [\sigma_i(X)], i = 1, 2, \dots, m \quad (7.3)$$

$$X_j \in R^d, \quad j = 1, 2, \dots, n \quad (7.4)$$

where  $C(X)$ ,  $\delta(X)$  and  $\sigma_i(X)$  as represent cost function, deflection and the behavioural constraints respectively whereas  $[\sigma_i(X)]$  denotes the maximum allowable value, 'm' and 'n' are the number of constraints and design variables respectively. A given set of discrete value is expressed by  $R^d$  and in this chapter objective functions are taken as

$$C(X) = \sum_{t=1}^T c_t \prod_{n=1}^m x_n^{m_n} \text{ and } \delta(X) \quad (7.5)$$

and constraint are chosen to be stress of structures as follows

$$\sigma_i(A) \lesssim \sigma_i \text{ with allowable tolerance } \sigma_i^0 \text{ for } i = 1, 2, \dots, m \quad (7.6)$$

Where  $c_t$  is the cost coefficient of  $t^{\text{th}}$  side and  $x_n$  is the  $n^{\text{th}}$  design variable respectively,  $m$  is the number of structural element,  $\sigma_i$  and  $\sigma_i^0$  are the  $i^{\text{th}}$  stress, allowable stress respectively.

## 7.2 Generalized Neutrosophic Goal Optimization Technique to Solve Multi-objective Welded Beam Optimization Problem (MOWBP)

The multi-objective neutrosophic structural model can be expressed as

(P7.2)

Minimize  $C(X)$  with target value  $C_0$ , truth tolerance  $a_c$ , indeterminacy tolerance  $d_c$  and rejection tolerance  $c_c$  (7.7)

Minimize  $\delta(X)$  with target value  $\delta_0$ , truth tolerance  $a_{\delta_0}$ , indeterminacy tolerance  $d_{\delta_0}$  and rejection tolerance  $c_{\delta_0}$  (7.8)

subject to  $\sigma(X) \leq [\sigma]$  (7.9)

$x_i^{\min} \leq x_i \leq x_i^{\max}$  (7.10)

where  $X = [x_1, x_2, \dots, x_n]^T$  are the design variables, n is the group number of design variables for the welded beam design.

To solve this problem we first calculate truth, indeterminacy and falsity membership function of objective as follows

$$T_C^{w_1}(C(X)) = \begin{cases} w_1 & \text{if } C(X) \leq C_0 \\ w_1 \left( \frac{C_0 + a_c - C(X)}{a_c} \right) & \text{if } C_0 \leq C(X) \leq C_0 + a_c \\ 0 & \text{if } C(X) \geq C_0 + a_c \end{cases} \quad (7.11)$$

$$I_{C(X)}^{w_2}(C(X)) = \begin{cases} 0 & \text{if } C(X) \leq C_0 \\ w_2 \left( \frac{C(X) - C_0}{d_c} \right) & \text{if } C_0 \leq C(X) \leq C_0 + a_c \\ w_2 \left( \frac{C_0 + a_c - C(X)}{a_c - d_c} \right) & \text{if } C_0 + d_c \leq C(X) \leq C_0 + a_c \\ 0 & \text{if } C(X) \geq C_0 + a_c \end{cases} \quad (7.12)$$

$$\text{where } d_c = \frac{w_1}{\frac{w_1}{a_c} + \frac{w_2}{c_c}} \quad (7.13)$$

$$F_{C(X)}^{w_3}(C(X)) = \begin{cases} 0 & \text{if } C(X) \leq C_0 \\ w_3 \left( \frac{C(X) - C_0}{c_c} \right) & \text{if } C_0 \leq C(X) \leq C_0 + c_c \\ w_3 & \text{if } C(X) \geq C_0 + c_c \end{cases} \quad (7.14)$$

And

$$T_{\delta(X)}^{w_1}(\delta(X)) = \begin{cases} w_1 & \text{if } \delta(X) \leq \delta_0 \\ w_1 \left( \frac{\delta_0 + a_{\delta_0} - \delta(X)}{a_{\delta_0}} \right) & \text{if } \delta_0 \leq \delta(X) \leq \delta_0 + a_{\delta_0} \\ 0 & \text{if } \delta(X) \geq \delta_0 + a_{\delta_0} \end{cases} \quad (7.15)$$

$$I_{\delta(X)}^{w_2}(\delta(X)) = \begin{cases} 0 & \text{if } \delta(X) \leq \delta_0 \\ w_2 \left( \frac{\delta(X) - \delta_0}{d_\delta} \right) & \text{if } \delta_0 \leq \delta(X) \leq \delta_0 + a_\delta \\ w_2 \left( \frac{\delta_0 + a_\delta - \delta(X)}{a_\delta - d_\delta} \right) & \text{if } \delta_0 + d_\delta \leq \delta(X) \leq \delta_0 + a_\delta \\ 0 & \text{if } \delta(X) \geq \delta_0 + a_\delta \end{cases} \quad (7.16)$$

$$d_\delta = \frac{w_1}{\frac{w_1}{a_\delta} + \frac{w_2}{c_\delta}} \quad (7.17)$$

$$F_{\delta(X)}^{w_3}(\delta(X)) = \begin{cases} 0 & \text{if } \delta(X) \leq \delta_0 \\ w_3 \left( \frac{\delta(X) - \delta_0}{c_\delta} \right) & \text{if } \delta_0 \leq \delta(X) \leq \delta_0 + c_\delta \\ w_3 & \text{if } \delta(X) \geq \delta_0 + c_\delta \end{cases} \quad (7.18)$$

According to Generalized Neutrosophic Goal Programming(GNGP) technique using truth, indeterminacy and falsity membership function ,MOSOP (P7.1) can be formulated as

**(P7.3)**

**Model -I**

$$\text{Maximize } \alpha, \text{ Maximize } \gamma, \text{ Minimize } \beta \quad (7.19)$$

$$C(X) \leq C_0 + a_c \left( 1 - \frac{\alpha}{w_1} \right), \quad (7.20)$$

$$C(X) \geq C_0 + \frac{d_c}{w_2} \gamma, \quad (7.21)$$



$$C(X) \leq C_0 + a_c - \frac{\gamma}{w_2}(a_c - d_c), \quad (7.22)$$

$$C(X) \leq C_0 + \frac{c_c}{w_3} \beta, \quad (7.23)$$

$$C(X) \leq C_0, \quad (7.24)$$

$$\delta(X) \leq \delta_0 + a_\delta \left(1 - \frac{\alpha}{w_1}\right), \quad (7.25)$$

$$\delta(X) \geq \delta_0 + \frac{d_\delta}{w_2} \gamma, \quad (7.26)$$

$$\delta(X) \leq \delta_0 + a_\delta - \frac{\gamma}{w_2}(a_\delta - d_\delta), \quad (7.27)$$

$$\delta(X) \leq \delta_0 + \frac{c_\delta}{w_3} \beta, \quad (7.28)$$

$$\delta(X) \leq \delta_0, \quad (7.29)$$

$$0 \leq \alpha + \beta + \gamma \leq w_1 + w_2 + w_3; \quad (7.30)$$

$$\alpha \in [0, w_1], \gamma \in [0, w_2], \beta \in [0, w_3]; \quad (7.31)$$

$$w_1 \in [0, 1], w_2 \in [0, 1], w_3 \in [0, 1]; \quad (7.32)$$

$$0 \leq w_1 + w_2 + w_3 \leq 3; \quad (7.33)$$

$$\sigma_i(X) \leq [\sigma], i = 1, 2, \dots, m \quad (7.34)$$

$$x_j \geq 0, \quad j = 1, 2, \dots, n \quad (7.35)$$

With the help of generalized truth, indeterminacy, falsity membership function the GNGP based on arithmetic aggregation operator (P7.1) can be formulated as

**(P7.4)**

**Model -II**

$$\text{Minimize } \left\{ \frac{(1-\alpha) + \beta + (1-\gamma)}{3} \right\} \quad (7.36)$$

Subjected to same constraint as Model I

With the help of generalized truth, indeterminacy, falsity membership function the GNGP based on geometric aggregation operator (P7.1) can be formulated as

**(P7.5)**

**Model -III**

$$\text{Minimize } \sqrt[3]{(1-\alpha)\beta(1-\gamma)} \quad (7.37)$$

Subjected to same constraint as Model I

Now these non-linear programming Model-I,II,III can be easily solved through an appropriate mathematical programming to give solution of MONLPP (P7.1) by GNGP approach.

### 7.3 Numerical Solution of welded Beam Design by GNGP, based on Different Operator

A welded beam (Ragsdell and Philips 1976, Fig.- 7.1) has to be designed at minimum cost whose constraints are shear stress in weld ( $\tau$ ), bending stress in the beam ( $\sigma$ ), buckling load

on the bar ( $P$ ), and deflection of the beam ( $\delta$ ). The design variables are  $\begin{bmatrix} x_1 \\ x_2 \\ x_3 \\ x_4 \end{bmatrix} = \begin{bmatrix} h \\ l \\ t \\ b \end{bmatrix}$  where  $h$  is

the weld size,  $l$  is the length of the weld,  $t$  is the depth of the welded beam,  $b$  is the width of the welded beam.

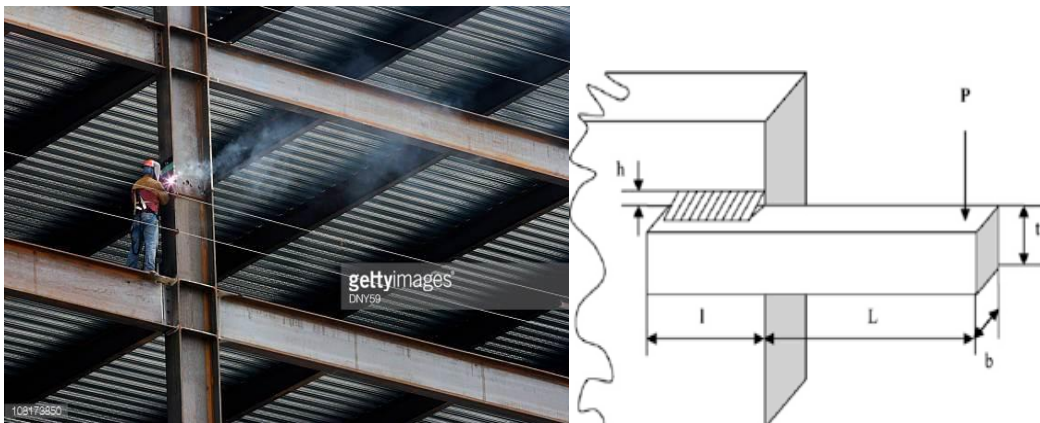

**Fig.-7.1 Design of the Welded Beam(Welded Beam on High Rise Building**  
<http://www.gettyimages.in>, accessed on 18 June 2017)

The multi-objective optimization problem can be stated as follows

**(P7.6)**

$$\text{Minimize } C(X) \equiv 1.10471x_1^2x_2 + 0.04811(14 + x_2)x_3x_4 \quad (7.38)$$

$$\text{Minimize } \delta(x) \equiv \frac{4PL^3}{Ex_4x_3^2}; \quad (7.39)$$

Such that

$$g_1(x) \equiv \tau(x) - \tau_{\max} \leq 0; \quad (7.40)$$

$$g_2(x) \equiv \sigma(x) - \sigma_{\max} \leq 0; \quad (7.41)$$

$$g_3(x) \equiv x_1 - x_4 \leq 0; \quad (7.42)$$

$$g_4(x) \equiv 0.10471x_1^2x_2 + 0.04811x_3x_4(14 + x_2) - 5 \leq 0; \quad (7.43)$$

$$g_5(x) \equiv 0.125 - x_1 \leq 0; \quad (7.44)$$

$$g_6(x) \equiv \delta(x) - \delta_{\max} \leq 0; \quad (7.45)$$

$$g_7(x) \equiv P - P_c(x) \leq 0; \quad (7.46)$$

$$0.1 \leq x_1, x_4, x_2, x_3 \leq 2.0 \quad (7.47)$$

$$\text{where } \tau(x) = \sqrt{\tau_1^2 + 2\tau_1\tau_2 \frac{x_2}{2R} + \tau_2^2}; \quad (7.48)$$

$$\tau_1 = \frac{P}{\sqrt{2}x_1x_2}; \quad (7.49)$$

$$\tau_2 = \frac{MR}{J}; \quad (7.50)$$

$$M = P\left(L + \frac{x_2}{2}\right); \quad (7.51)$$

$$R = \sqrt{\frac{x_2^2}{4} + \left(\frac{x_1 + x_3}{2}\right)^2}; \quad (7.52)$$

$$J = \left\{ \frac{x_1x_2}{\sqrt{2}} \left[ \frac{x_2^2}{12} + \left(\frac{x_1 + x_3}{2}\right)^2 \right] \right\}; \quad (7.53)$$

$$\sigma(x) = \frac{6PL}{x_4x_3^2}; \quad (7.54)$$

$$\delta(x) = \frac{4PL^3}{Ex_4x_3^2}; \quad (7.55)$$

$$P_c(x) = \frac{4.013\sqrt{EGx_3^6x_4^6/36}}{L^2} \left( 1 - \frac{x_3}{2L} \sqrt{\frac{E}{4G}} \right); \quad (7.56)$$

$P$  = Force on beam ;  $L$  = Beam length beyond weld;  $x_1$  = Height of the welded beam;  $x_2$  = Length of the welded beam;  $x_3$  = Depth of the welded beam;  $x_4$  = Width of the welded beam;  $\tau(x)$  = Design shear stress;  $\sigma(x)$  = Design normal stress for beam material;  $M$  = Moment of  $P$  about the centre of gravity of the weld ,  $J$  = Polar moment of inertia of weld group;  $G$  = Shearing modulus of Beam Material;  $E$  = Young modulus;  $\tau_{\max}$  = Design Stress of the weld;  $\sigma_{\max}$  = Design normal stress for the beam material;  $\delta_{\max}$  = Maximum deflection;  $\tau_1$  = Primary stress on weld throat.  $\tau_2$  = Secondary torsional stress on weld. Input data are given in Table 7.1.

**Table 7.1 Input Data for Crisp Model (P7.6)**

Applied load $P$ (lb)	Beam length beyond weld $L$ (in)	Young Modulus $E$ (psi)	Value of $G$ (psi)	Maximum allowable shear stress $\tau_{\max}$ (psi)	Maximum allowable normal stress $\sigma_{\max}$ (psi)	Maximum allowable deflection $\delta_{\max}$ (in)
6000	14	$3 \times 10^6$	$12 \times 10^6$	13600 with fuzzy region 50	30000 with fuzzy region 50	0.25 with fuzzy region 0.05

This multi objective structural model can be expressed as neutrosophic model as

**(P7.7)**

Minimize  $C(X) \equiv 1.10471x_1^2x_2 + 0.04811(14 + x_2)x_3x_4$  with target value 3.39 ,truth tolerance

$$5 \text{ ,indeterminacy tolerance } \frac{w_1}{0.2w_1 + 0.14w_2} \text{ and rejection tolerance } 7 \quad (7.57)$$

Minimize  $\delta(x) \equiv \frac{4PL^3}{Ex_4x_3^2}$ ; with target value 0.20 ,truth tolerance 0.23 ,indeterminacy

$$\text{tolerance } \frac{w_1}{4.34w_1 + 4.16w_2} \text{ and rejection tolerance } 0.24 \quad (7.58)$$

Subject to

$$g_1(x) \equiv \tau(x) - \tau_{\max} \leq 0; \quad (7.59)$$

$$g_2(x) \equiv \sigma(x) - \sigma_{\max} \leq 0; \quad (7.60)$$

$$g_3(x) \equiv x_1 - x_4 \leq 0; \quad (7.61)$$

$$g_4(x) \equiv 0.10471x_1^2x_2 + 0.04811x_3x_4(14 + x_2) - 5 \leq 0; \quad (7.62)$$

$$g_5(x) \equiv 0.125 - x_1 \leq 0; \quad (7.63)$$

$$g_6(x) \equiv \delta(x) - \delta_{\max} \leq 0; \quad (7.64)$$

$$g_7(x) \equiv P - P_c(x) \leq 0; \quad (7.65)$$

$$0.1 \leq x_1, x_4, x_2, x_3 \leq 2.0 \quad (7.66)$$

$$\text{where } \tau(x) = \sqrt{\tau_1^2 + 2\tau_1\tau_2 \frac{x_2}{2R} + \tau_2^2}; \quad (7.67)$$

$$\tau_1 = \frac{P}{\sqrt{2x_1x_2}}; \quad (7.68)$$

$$\tau_2 = \frac{MR}{J}; \quad (7.69)$$

$$M = P \left( L + \frac{x_2}{2} \right); \quad (7.70)$$

$$R = \sqrt{\frac{x_2^2}{4} + \left( \frac{x_1 + x_3}{2} \right)^2}; \quad (7.71)$$

$$J = \left\{ \frac{x_1x_2}{\sqrt{2}} \left[ \frac{x_2^2}{12} + \left( \frac{x_1 + x_3}{2} \right)^2 \right] \right\}; \quad (7.72)$$

$$\sigma(x) = \frac{6PL}{x_4x_3^2}; \quad (7.73)$$

$$\delta(x) = \frac{4PL^3}{Ex_4x_3^2}; \quad (7.74)$$

$$P_c(x) = \frac{4.013\sqrt{EGx_3^6x_4^6/36}}{L^2} \left( 1 - \frac{x_3}{2L} \sqrt{\frac{E}{4G}} \right); \quad (7.75)$$

According to GNGP technique using truth, indeterminacy and falsity membership function, MOWBP (P7.7) can be formulated as

**(P7.8)**

**Model -I**

$$\text{Maximize } \alpha, \text{ Maximize } \gamma, \text{ Minimize } \beta \quad (7.76)$$

$$1.10471x_1^2x_2 + 0.04811(14 + x_2)x_3x_4 \leq 3.39 + 5\left(1 - \frac{\alpha}{w_1}\right), \quad (7.77)$$

$$1.10471x_1^2x_2 + 0.04811(14 + x_2)x_3x_4 \geq 3.39 + \frac{w_1}{w_2(0.2w_1 + 0.14w_2)}\gamma, \quad (7.78)$$

$$1.10471x_1^2x_2 + 0.04811(14 + x_2)x_3x_4 \leq 3.39 + 5 - \frac{\gamma}{w_2}\left(2 - \frac{w_1}{(0.2w_1 + 0.14w_2)}\right), \quad (7.79)$$

$$1.10471x_1^2x_2 + 0.04811(14 + x_2)x_3x_4 \leq 3.39 + \frac{7}{w_3}\beta, \quad (7.80)$$

$$1.10471x_1^2x_2 + 0.04811(14 + x_2)x_3x_4 \leq 3.39, \quad (7.81)$$

$$\frac{4PL^3}{Ex_4x_3^2} \leq 0.20 + 0.23\left(1 - \frac{\alpha}{w_1}\right), \quad (7.82)$$

$$\frac{4PL^3}{Ex_4x_3^2} \geq 0.20 + \frac{w_1}{w_2(4.3w_1 + 4.1w_2)}\gamma, \quad (7.83)$$

$$\frac{4PL^3}{Ex_4x_3^2} \leq 0.20 + 0.23 - \frac{\gamma}{w_2}\left(0.23 - \frac{w_1}{(4.3w_1 + 4.1w_2)}\right), \quad (7.84)$$

$$\frac{4PL^3}{Ex_4x_3^2} \leq 0.20 + \frac{0.24}{w_3}\beta, \quad (7.85)$$

$$\frac{4PL^3}{Ex_4x_3^2} \leq 0.20, \quad (7.86)$$

$$0 \leq \alpha + \beta + \gamma \leq w_1 + w_2 + w_3; \quad (7.87)$$

$$\alpha \in [0, w_1], \gamma \in [0, w_2], \beta \in [0, w_3]; \quad (7.88)$$

$$w_1 \in [0, 1], w_2 \in [0, 1], w_3 \in [0, 1]; \quad (7.89)$$

$$0 \leq w_1 + w_2 + w_3 \leq 3; \quad (7.90)$$

$$g_1(x) \equiv \tau(x) - \tau_{\max} \leq 0; \quad (7.91)$$

$$g_2(x) \equiv \sigma(x) - \sigma_{\max} \leq 0; \quad (7.92)$$

$$g_3(x) \equiv x_1 - x_4 \leq 0; \quad (7.93)$$

$$g_4(x) \equiv 0.10471x_1^2x_2 + 0.04811x_3x_4(14 + x_2) - 5 \leq 0; \quad (7.94)$$

$$g_5(x) \equiv 0.125 - x_1 \leq 0; \quad (7.95)$$

$$g_6(x) \equiv \delta(x) - \delta_{\max} \leq 0; \quad (7.96)$$

$$g_7(x) \equiv P - P_c(x) \leq 0; \quad (7.97)$$

$$0.1 \leq x_1, x_4, x_2, x_3 \leq 2.0 \quad (7.98)$$

$$\text{where } \tau(x) = \sqrt{\tau_1^2 + 2\tau_1\tau_2 \frac{x_2}{2R} + \tau_2^2}; \quad (7.99)$$

$$\tau_1 = \frac{P}{\sqrt{2}x_1x_2}; \quad (7.100)$$

$$\tau_2 = \frac{MR}{J}; \quad (7.101)$$

$$M = P\left(L + \frac{x_2}{2}\right); \quad (7.102)$$

$$R = \sqrt{\frac{x_2^2}{4} + \left(\frac{x_1 + x_3}{2}\right)^2}; \quad (7.103)$$

$$J = \left\{ \frac{x_1x_2}{\sqrt{2}} \left[ \frac{x_2^2}{12} + \left(\frac{x_1 + x_3}{2}\right)^2 \right] \right\}; \quad (7.104)$$

$$\sigma(x) = \frac{6PL}{x_4x_3^2}; \quad (7.105)$$

$$\delta(x) = \frac{4PL^3}{Ex_4x_3^2}; \quad (7.106)$$

$$P_c(x) = \frac{4.013\sqrt{EGx_3^6x_4^6/36}}{L^2} \left( 1 - \frac{x_3}{2L} \sqrt{\frac{E}{4G}} \right); \quad (7.107)$$

With the help of generalized truth, indeterminacy, falsity membership function the GNGP problem (P7.7) based on arithmetic aggregation operator can be formulated as

**(P7.9)**

**Model -II**

$$\text{Minimize } \left\{ \frac{(1-\alpha) + \beta + (1-\gamma)}{3} \right\} \quad (7.108)$$

subjected to same constraints as (P7.8)

With the help of generalized truth, indeterminacy, falsity membership function the GNGP problem (P7.7) based on geometric aggregation operator can be formulated as

(P7.10)

**Model -III**

$$\text{Minimize } \sqrt[3]{(1-\alpha)\beta(1-\gamma)} \tag{7.109}$$

subjected to same constraints as (P7.8)

Now these non-linear programming problem Model-I,II,III can be easily solved by an appropriate mathematical programming to give solution of multi-objective non-linear programming problem (P7.7) by GNGP approach and the results are shown in Table 7.2.

**Table 7.2 Comparison of GNGP Solution of MOWBP (P8.12) based on Different Aggregation**

Methods	$x_1$ in	$x_2$ in	$x_3$ in	$x_4$ in	$C(X)$	$\delta(X)$
Generalized Fuzzy Goal programming(GFGP) $w_1 = 0.15$	1.297612	0.9717430	1.693082	1.297612	3.39	0.20
Generalized Intuitionistic Fuzzy Goal programming(GIFGP) $w_1 = 0.15, w_3 = 0.8$	1.297612	0.9717430	1.693082	1.297612	3.39	0.20
Generalized Neutrosophic Goal programming (GNGP) $w_1 = 0.4, w_2 = 0.3, w_3 = 0.7$	1.347503	0.7374240	2	1.347503	3.39	2
Generalized Intuitionistic Fuzzy optimization (GIFGP) based on Arithmetic Aggregation $w_1 = 0.15, w_3 = 0.8$	1.297612	0.9717430	1.693082	1.297612	3.39	0.20
Generalized Neutrosophic optimization (GNGP) based on Arithmetic Aggregation $w_1 = 0.4, w_2 = 0.3, w_3 = 0.7$	1.347503	0.7374240	2	1.347503	3.39	0.20
Generalized Intuitionistic Fuzzy optimization (GIFGP) based on Geometric Aggregation $w_1 = 0.15, w_3 = 0.8$	1.372	0.697176	2	1.37200	3.39	0.2
Generalized Neutrosophic optimization (GNGP) based on Geometric	1.372	0.6971	2	1.372	3.39	0.2



Aggregation $w_1 = 0.4, w_2 = 0.3, w_3 = 0.7$						
--	--	--	--	--	--	--

Here we have got almost same solutions for the different value of  $w_1, w_2, w_3$  in different aggregation method for objective functions. From Table 7.2 it is clear that the cost of welding and deflection are almost same in fuzzy and intuitionistic fuzzy as well as NSO technique. Moreover it has been seen that desired value obtained in different aggregation method have not affected by variation of methods in perspective of welded beam design optimization.

### 7.4 Conclusion

The research study investigates that NGP can be utilized to optimize a nonlinear welded beam design problem. The results obtained for different aggregation method of the undertaken problem show that the best result is achieved using geometric aggregation method. The concept of NSO technique allows one to define a degree of truth membership, which is not a complement of degree of falsity; rather, they are independent with degree of indeterminacy. As we have considered a non-linear welded beam design problem and find out minimum cost of welding of the structure as well as minimum deflection, the results of this study may lead to the development of effective neutrosophic technique for solving other model of nonlinear programming problem in different field.

# CHAPTER 8

---

## Truss Design Optimization with Imprecise Load and Stress in Neutrosophic Environment

---

Optimization techniques for structural optimal design, consisting of deterministic optimization and non-deterministic optimization methods, have been widely used in practice. The former i.e deterministic optimization aims to search the optimum solution under given constraints without consideration of uncertainties. However, in so many engineering structures, deterministic optimization approaches are unable to handle structural performances exhibit variations such as the fluctuation of external loads, the variation of material properties, e.t.c due to the presence of uncertainties, the so-called optimum solution obtained may lie in the infeasible region. Thus, so many realistic design-approaches must be able to deal with the imprecise nature of structures. This type of optimum solution has been obtained under given reliability constraints, while the later one aims to minimize the variation of the objective function. Such several non-deterministic structural design optimization approaches which are reliability-based design optimization (RBDO), solved by D.M Frangopol et.al[47]and M. Papadrakakis [83], considering structural impreciseness, have been reported in the literature. Moreover in the practical optimization problems usually more than one objective is required to be optimized. Generally they are minimum cost, maximum stiffness, minimum displacement at specific structural nodes, maximum natural frequency of free vibration and optimum structural strain energy e.t.c. These make it necessary to formulate a multi-objective optimization problem. The applications of different optimization techniques to structural design have attracted interest of many researchers. For example Ray Optimization (Kaveh. Et.al [60]), artificial bee colony algorithm (Sonmez, M.[108]),Particle Swarm Optimization (Perez et. al [84],Kaveh et.al [61] and Luh,et.al.[70]),genetic Algorithm (Kaveh,et.al[62],Ali.et.al[7],Dede,et.al[42]), meta heuristic algorithm (Kaveh,A. Motie ,S.Mohammed ,A.,Moslehi,M.[63]),others (Shih, C.j. and Chang,C.J.[109],Hajela,P. and Shih,C.J.[54]Wang ,D.,Zhang,W.H.and Jiang,J.S.[126],Wang ,D.,Zhang,W.H. and Jiang ,J.S.[127];Kripakaran,P.,Gupta,A. and Baugh Jr,J.W.[64]).Fuzzy as well as intuitionistic fuzzy optimization, not only help the engineers, especially in structural engineering, to design and to analyse the systems but also leads to discover fuzzy optimization theory and techniques. This Fuzzy Set(FS) theory was first introduced by Zadeh[133]. As an extension Intuitionistic Fuzzy Set(IFS) theory was first introduced by Atanassov[1] .When an imprecise information can not be expressed by means of conventional FS, IFS plays an important role. In IFS we usually consider degree of acceptance, and degree of rejection where as we consider only membership function in FS. A few research work has been done on Intuitionistic Fuzzy Optimization(IFO) in the field of

structural optimization. Dey and Roy [35] used IF technique to optimize single objective two bar truss structural model. A Multi-Objective Intuitionistic Fuzzy Optimization(MOIFO) technique is applied to optimize three bar truss structural model by Dey and Roy [36] in their paper. When an ill-known information are represented by IF number which is generalization of fuzzy number expresses the available information in flexible way considering non-membership functions. Shu [110] applied Triangular Intuitionistic Fuzzy Number(TIFN) to fault tree analysis on printed board circuit assembly. P.Grzegorzewski et.al [48], H.B.Mitchell et.al [75], G.Nayagam et.al [78], H.M.Nehi et.al [79], S.Rezvani et.al [92] used concept of Intuitionistic Fuzzy Number(IFN) in multi-attribute decision making(MADM) problem. Li[69] proposed a ranking method for TIFN with definition of ratio of value index to ambiguity index of TIFN in MADM problem as an application. In IFN indeterminate information is partially lost, as hesitant information is taken in consideration by default. So indeterminate information should be considered in decision making process. Smarandache [94] defined Neutrosophic Set(NS) that could handle indeterminate and inconsistent information. In NS indeterminacy is quantified explicitly with truth membership, indeterminacy membership and falsity membership function which are independent. Wang et.al [120] define single valued NS which represents imprecise, incomplete, indeterminate, inconsistent information. Thus taking the universe as a real line we can develop the concept of single valued neutrosophic number as special case of NS. These numbers are able to express ill-known quantity with uncertain numerical value in decision making problem. In this present study, we define generalized single valued triangular neutrosophic number and total integral value of this number and using a ranking method of single valued generalized triangular neutrosophic number we solve a multi-objective structural design problem in neutrosophic environment. In this chapter we have considered three-bar planer truss subjected to a single load condition. Here the objective functions are weight of the truss and deflection of loaded joint in test problem and the design variables are the cross-sections of bars with the constraints as stresses in members. In this chapter we have developed an approach to solve multi-objective structural design using probabilistic operator in neutrosophic environment. Here total integral values of Generalized Single Valued Triangular Neutrosophic Numbers(GSVTNN) have been considered for applied load and stress.

## **8.1 Multi-Objective Structural Design Formulation**

A structural design problem may be considered as a minimization type Multi-Objective Nonlinear Programming Problem(MONLPP) where weight and deflection of the loaded joint are to be minimized as objectives and subject to a specified set of stress constraints. The design variables are cross sectional area of bars. The target of optimization is the identification of the optimum cross-sectional area of bar so that the structure can achieve its smallest total weight with minimum nodal displacement, in a given load conditions.

The multi-objective structural model can be expressed as

**(P8.1)**

$$\text{Minimize } WT(A) \quad (8.1)$$

$$\text{Minimize } \delta(A) \quad (8.2)$$

$$\text{subject to } \sigma_i(A) \leq [\sigma_i] \quad (8.3)$$

$$A^{\min} \leq A \leq A^{\max} \quad (8.4)$$

where  $A = [A_1, A_2, \dots, A_n]^T$  are the design variables for the cross section, n is the group number of design variables for the cross section of bars,

$$WT(A) = \sum_{i=1}^n \rho_i A_i L_i \quad (8.5)$$

is the total weight of the structure,  $\delta(A)$  is the deflection of the loaded joint, where  $L_i, A_i$  and  $\rho_i$  are the length of bar, cross section area and density of the  $i^{th}$  group bars respectively.  $\sigma_i(A)$  is the stress constraints and  $[\sigma_i]$  is allowable stress of the group bars under various conditions,  $A^{\min}$  and  $A^{\max}$  are the lower and upper bounds of cross section area A respectively.

## 8.2 Parametric Neutrosophic Optimization Technique to Solve Multi-Objective Structural Optimization Problem

The multi-objective structural model (P8.1) can be expressed as parametric neutrosophic form as

**(P8.2)**

$$\text{Minimize } WT(A; \alpha); \text{Minimize } WT(A; \beta); \text{Minimize } WT(A; \gamma) \quad (8.6)$$

$$\text{Minimize } \delta(A; \alpha); \text{Minimize } \delta(A; \beta); \text{Minimize } \delta(A; \gamma) \quad (8.7)$$

subject to

$$\sigma(A; \alpha) \leq ([\sigma]; \alpha); \quad (8.8)$$

$$\sigma(A; \beta) \leq ([\sigma]; \beta); \quad (8.9)$$

$$\sigma(A; \gamma) \leq ([\sigma]; \gamma) \quad (8.10)$$

$$A^{\min} \leq A \leq A^{\max} \quad \alpha, \beta, \gamma \in [0, 1] \quad (8.11)$$

Where  $A = (A_1, A_2, \dots, A_n)^T$

To solve the MOSOP (P8.1) step 1 of 1.39 is used. After that according to step 2 pay-off matrix is formulated

$$\begin{array}{c} WT(A; \alpha) \quad WT(A; \beta) \quad WT(A; \gamma) \quad \delta(A; \alpha) \quad \delta(A; \beta) \quad \delta(A; \gamma) \\ A^1 \left[ \begin{array}{cccccc} WT^*(A^1; \alpha) & WT^*(A^1; \beta) & WT^*(A^1; \gamma) & \delta^*(A^1; \alpha) & \delta^*(A^1; \beta) & \delta^*(A^1; \gamma) \\ A^2 & WT^*(A^2; \alpha) & WT^*(A^2; \beta) & WT^*(A^2; \gamma) & \delta^*(A^2; \alpha) & \delta^*(A^2; \beta) & \delta^*(A^2; \gamma) \\ A^3 & WT^*(A^3; \alpha) & WT^*(A^3; \beta) & WT^*(A^3; \gamma) & \delta^*(A^3; \alpha) & \delta^*(A^3; \beta) & \delta^*(A^3; \gamma) \\ \cdot & \dots & \dots & \dots & \dots & \dots & \dots \\ \cdot & \dots & \dots & \dots & \dots & \dots & \dots \\ A^6 & WT^*(A^6; \alpha) & WT^*(A^6; \beta) & WT^*(A^6; \gamma) & \delta^*(A^6; \alpha) & \delta^*(A^6; \beta) & \delta^*(A^6; \gamma) \end{array} \right] \end{array}$$

Here  $A^1, A^2, \dots, A^6$  are the ideal solution of the objectives  $WT(A; \alpha), WT(A; \beta), WT(A; \gamma), \delta(A; \alpha), \delta(A; \beta), \delta(A; \gamma)$  respectively.

For each objective  $WT(A; \alpha), WT(A; \beta), WT(A; \gamma), \delta(A; \alpha), \delta(A; \beta), \delta(A; \gamma)$  find lower bound  $L_k^T$  and the upper bound  $U_k^T$  as

$$U_{WT(A_r^*; p)}^T = \max \{ WT(A_r^*; p) \} \quad 0 \leq r \leq 6; p = \alpha, \beta, \gamma \quad (8.12)$$

$$L_{WT(A_r^*; p)}^T = \min \{ WT(A_r^*; p) \} \quad 0 \leq r \leq 6; p = \alpha, \beta, \gamma \quad (8.13)$$

for truth membership of weight functions and

$$U_{\delta(A_r^*; p)}^T = \max \{ \delta(A_r^*; p) \} \quad 0 \leq r \leq 6; p = \alpha, \beta, \gamma \quad (8.14)$$

$$L_{\delta(A_r^*; p)}^T = \min \{ \delta(A_r^*; p) \} \quad 0 \leq r \leq 6; p = \alpha, \beta, \gamma \quad (8.15)$$

for truth membership of deflection functions

Similarly the upper and lower bounds for indeterminacy and falsity membership of weight objective function as

$$U_{WT(A_r^*; p)}^F = U_{WT(A_r^*; p)}^T; \quad (8.16)$$

$$L_{WT(A_r^*; p)}^F = L_{WT(A_r^*; p)}^T + t \left( U_{WT(A_r^*; p)}^T - L_{WT(A_r^*; p)}^T \right); \quad (8.17)$$

$$L_{WT(A_r^*; p)}^I = L_{WT(A_r^*; p)}^T; \quad (8.18)$$

$$U_{WT(A_r^*; p)}^I = L_{WT(A_r^*; p)}^T + s \left( U_{WT(A_r^*; p)}^T - L_{WT(A_r^*; p)}^T \right); \quad 0 \leq r \leq 6; p = \alpha, \beta, \gamma \quad (8.19)$$

And deflection objective function as

$$U_{\delta(A_r^*;p)}^F = U_{\delta(A_r^*;p)}^T, \quad (8.20)$$

$$L_{\delta(A_r^*;p)}^F = L_{\delta(A_r^*;p)}^T + t \left( U_{\delta(A_r^*;p)}^T - L_{\delta(A_r^*;p)}^T \right); \quad (8.21)$$

$$L_{\delta(A_r^*;p)}^I = L_{\delta(A_r^*;p)}^T, \quad (8.22)$$

$$U_{\delta(A_r^*;p)}^I = L_{\delta(A_r^*;p)}^T + s \left( U_{\delta(A_r^*;p)}^T - L_{\delta(A_r^*;p)}^T \right); 0 \leq r \leq 6; p = \alpha, \beta, \gamma \quad (8.23)$$

Here  $t, s$  are predetermined real numbers in  $(0,1)$

Define truth membership, indeterminacy membership and falsity membership functions for weight and deflection as follows

$$T_{WT(A;p)}(WT(A;p)) = \begin{cases} 1 & \text{if } WT(A;p) \leq L_{WT(A;p)}^T \\ 1 - \exp \left\{ -\psi \left( \frac{U_{WT(A;p)}^T - WT(A;p)}{U_{WT(A;p)}^T - L_{WT(A;p)}^T} \right) \right\} & \text{if } L_{WT(A;p)}^T \leq WT(A;p) \leq U_{WT(A;p)}^T \\ 0 & \text{if } WT(A;p) \geq U_{WT(A;p)}^T \end{cases} \quad (8.24)$$

$$I_{WT(A;p)}(WT(A;p)) = \begin{cases} 1 & \text{if } WT(A;p) \leq L_{WT(A;p)}^I \\ \exp \left\{ \frac{U_{WT(A;p)}^I - WT(A;p)}{U_{WT(A;p)}^I - L_{WT(A;p)}^I} \right\} & \text{if } L_{WT(A;p)}^I \leq WT(A;p) \leq U_{WT(A;p)}^I \\ 0 & \text{if } WT(A;p) \geq U_{WT(A;p)}^I \end{cases} \quad (8.25)$$

$$F_{WT(A;p)}(WT(A;p)) = \begin{cases} 0 & \text{if } WT(A;p) \leq L_{WT(A;p)}^F \\ \frac{1}{2} + \frac{1}{2} \tanh \left\{ \left( WT(A;p) - \frac{U_{WT(A;p)}^F + L_{WT(A;p)}^F}{2} \right) \theta_{WT(A;p)} \right\} & \text{if } L_{WT(A;p)}^F \leq WT(A;p) \leq U_{WT(A;p)}^F \\ 1 & \text{if } WT(A;p) \geq U_{WT(A;p)}^F \end{cases} \quad (8.26)$$

$$T_{\delta(A;p)}(\delta(A;p)) = \begin{cases} 1 & \text{if } \delta(A;p) \leq L_{\delta(A;p)}^T \\ 1 - \exp \left\{ -\psi \left( \frac{U_{\delta(A;p)}^T - \delta(A;p)}{U_{\delta(A;p)}^T - L_{\delta(A;p)}^T} \right) \right\} & \text{if } L_{\delta(A;p)}^T \leq \delta(A;p) \leq U_{\delta(A;p)}^T \\ 0 & \text{if } \delta(A;p) \geq U_{\delta(A;p)}^T \end{cases} \quad (8.27)$$

$$I_{\delta(A;p)}(\delta(A;p)) = \begin{cases} 1 & \text{if } \delta(A;p) \leq L_{\delta(A;p)}^I \\ \exp\left\{\frac{U_{\delta(A;p)}^I - \delta(A;p)}{U_{\delta(A;p)}^I - L_{\delta(A;p)}^I}\right\} & \text{if } L_{\delta(A;p)}^I \leq \delta(A;p) \leq U_{\delta(A;p)}^I \\ 0 & \text{if } \delta(A;p) \geq U_{\delta(A;p)}^I \end{cases} \quad (8.28)$$

$$F_{\delta(A;p)}(\delta(A;p)) = \begin{cases} 0 & \text{if } \delta(A;p) \leq L_{\delta(A;p)}^F \\ \frac{1}{2} + \frac{1}{2} \tanh\left\{\left(\delta(A;p) - \frac{U_{\delta(A;p)}^F + L_{\delta(A;p)}^F}{2}\right)\theta_{\delta(A;p)}\right\} & \text{if } L_{\delta(A;p)}^F \leq \delta(A;p) \leq U_{\delta(A;p)}^F \\ 1 & \text{if } \delta(A;p) \geq U_{\delta(A;p)}^F \end{cases} \quad (8.29)$$

$$\text{Where } \theta_{WT(A;p)} = \frac{6}{U_{WT(A;p)}^F - L_{WT(A;p)}^F}; \quad (8.30)$$

$$\theta_{\delta(A;p)} = \frac{6}{U_{\delta(A;p)}^F - L_{\delta(A;p)}^F}; \quad (8.31)$$

$$\psi = 4 \quad 0 \leq r \leq 6; p = \alpha, \beta, \gamma \quad (8.32)$$

Now NSO method for MONLP problem with probabilistic operator gives a equivalent nonlinear programming problem as

**(P8.3)**

$$\text{Maximize } \begin{cases} T_{WT(A;\alpha)}(WT(A;\alpha))T_{WT(A;\beta)}(WT(A;\beta))T_{WT(A;\gamma)}(WT(A;\gamma))T_{\delta(A;\alpha)}(\delta(A;\alpha)) \\ T_{\delta(A;\beta)}(\delta(A;\beta))T_{\delta(A;\gamma)}(\delta(A;\gamma)) \end{cases} \quad (8.33)$$

$$\text{Minimize } \begin{cases} [1 - I_{WT(A;\alpha)}(WT(A;\alpha))][1 - I_{WT(A;\beta)}(WT(A;\beta))][1 - I_{WT(A;\gamma)}(WT(A;\gamma))] \\ [1 - I_{\delta(A;\alpha)}(\delta(A;\alpha))][1 - I_{\delta(A;\beta)}(\delta(A;\beta))][1 - I_{\delta(A;\gamma)}(\delta(A;\gamma))] \end{cases} \quad (8.34)$$

$$\text{Minimize } \begin{cases} [1 - F_{WT(A;\alpha)}(WT(A;\alpha))][1 - F_{WT(A;\beta)}(WT(A;\beta))][1 - F_{WT(A;\gamma)}(WT(A;\gamma))] \\ [1 - F_{\delta(A;\alpha)}(\delta(A;\alpha))][1 - F_{\delta(A;\beta)}(\delta(A;\beta))][1 - F_{\delta(A;\gamma)}(\delta(A;\gamma))] \end{cases} \quad (8.35)$$

subject to

$$0 \leq T_{WT(A;p)}(WT(A;p)) + I_{WT(A;p)}(WT(A;p)) + F_{WT(A;p)}(WT(A;p)) \leq 3; \quad (8.36)$$

$$0 \leq T_{\delta(A;p)}(\delta(A;p)) + I_{\delta(A;p)}(\delta(A;p)) + F_{\delta(A;p)}(\delta(A;p)) \leq 3; \quad (8.37)$$

$$\sigma(A) \leq [\sigma]; \quad (8.38)$$

$$A^{\min} \leq A \leq A^{\max} \quad 0 \leq r \leq 6; p = \alpha, \beta, \gamma; \alpha, \beta, \gamma \in [0,1] \quad (8.39)$$

This crisp nonlinear programming problem can be solved by appropriate mathematical algorithm.

### 8.3 Numerical Solution of Three Bar Truss Design using Parametric Neutrosophic Optimization Technique

A well known three bar planer truss( Fig. -8.1) is considered to minimize weight of the structure  $WT(A_1, A_2)$  and minimize the deflection  $\delta(A_1, A_2)$  at a loading point of a statistically loaded three bar planer truss subject to stress constraints on each of the truss members

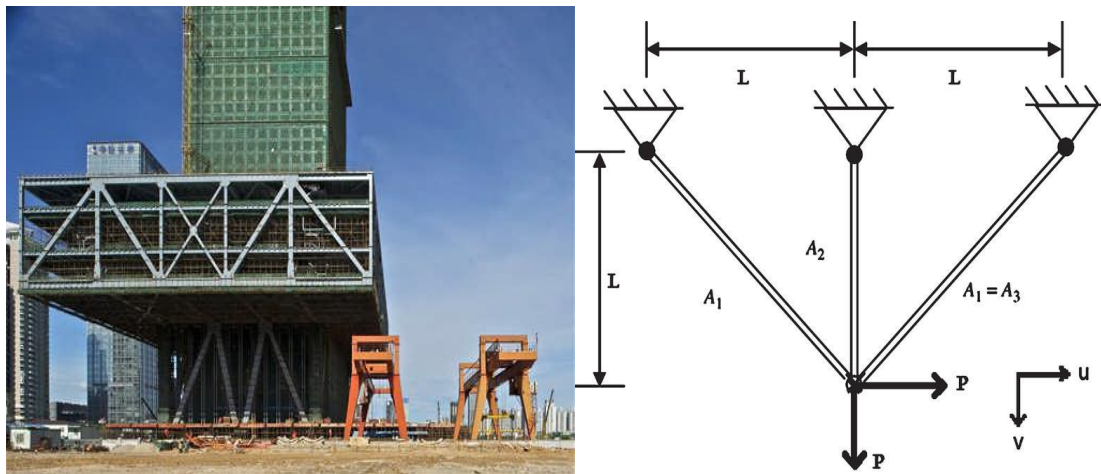

**Fig.-8.1 Design of the Three-Bar Planar Truss(Shenzhen Stock Exchange, <https://www.e-architect.co.uk>, accessed on 18 June 2017)**

The multi-objective optimization problem can be stated as follows

**(P8.4)**

$$\text{Minimize } WT(A_1, A_2) = \rho L (2\sqrt{2}A_1 + A_2) \quad (8.40)$$

$$\text{Minimize } \delta_u(A_1, A_2) = \frac{LP}{EA_1} \quad (8.41)$$

$$\text{Minimize } \delta_v(A_1, A_2) = \frac{LP}{E(A_1 + \sqrt{2}A_2)} \quad (8.42)$$

such that



$$\sigma_1(A_1, A_2) = \frac{P(2A_1 + \sqrt{2}A_2)}{(A_1^2 + \sqrt{2}A_1A_2)} \leq [\sigma_1^T] \quad (8.43)$$

$$\sigma_2(A_1, A_2) = \frac{P}{(A_1 + \sqrt{2}A_2)} \leq [\sigma_2^T] \quad (8.44)$$

$$\sigma_3(A_1, A_2) = \frac{PA_2}{(\sqrt{2}A_1^2 + 2A_1A_2)} \leq [\sigma_3^C] \quad (8.45)$$

$$A_i^{\min} \leq A_i \leq A_i^{\max} \quad i = 1, 2. \quad (8.46)$$

Where applied load

$$\tilde{P}^n \equiv \tilde{20}^n \equiv ((19, 20, 21; w_p)(18, 20, 22; \eta_p)(17, 20, 23; \tau_p)); \quad (8.47)$$

material density  $\rho = 100\text{KN/m}^3$ ; length  $L = 1\text{m}$ ; Young's modulus  $E = 2 \times 10^8$ ;  $A_1$  = Cross section of bar-1 and bar-3;  $A_2$  = Cross section of bar-2;  $\delta_u$  and  $\delta_v$  are the deflection of loaded joint along  $u$  and  $v$  axes respectively.

$$[\tilde{\sigma}_1^{Tn}] \equiv \tilde{20}^n \equiv ((19.5, 20, 20.5; w_{\sigma_1^T})(18, 20, 21; \eta_{\sigma_1^T})(17.5, 20, 21.5; \tau_{\sigma_1^T})) \quad (8.48)$$

$$\text{and } [\tilde{\sigma}_2^{Tn}] \equiv \tilde{20}^n \equiv ((18.5, 20, 21; w_{\sigma_2^T})(18, 20, 21.5; \eta_{\sigma_2^T})(17.5, 20, 22; \tau_{\sigma_2^T})) \quad (8.49)$$

are maximum allowable tensile stress for bar 1 and bar 2 respectively,

$$[\tilde{\sigma}_3^{Cn}] \equiv \tilde{15}^n \equiv ((14, 15, 16; w_{\sigma_3^C})(13, 15, 17; \eta_{\sigma_3^C})(13.5, 15, 17.5; \tau_{\sigma_3^C})) \quad (8.50)$$

is maximum allowable compressive stress for bar 3 where  $w_p = 0.8, w_{\sigma_1^T} = 0.7, w_{\sigma_2^T} = 0.6, w_{\sigma_3^C} = 0.9$  are degree of aspiration level of applied load, tensile stresses and compressive stress respectively and  $\eta_p = 0.4, \eta_{\sigma_1^T} = 0.5, \eta_{\sigma_2^T} = 0.3, \eta_{\sigma_3^C} = 0.4; \tau_p = 0.2, \tau_{\sigma_1^T} = 0.2, \tau_{\sigma_2^T} = 0.2, \tau_{\sigma_3^C} = 0.1$  are degree of hesitancy and desperation level of applied load, tensile stresses and compressive stress respectively.

Now total integral value of membership and non-membership function are

$$\hat{P}_1 = 22.43 + 0.75\alpha; \quad (8.51)$$

$$\hat{P}_2 = 19.5 + 5\beta; \hat{P}_2 = 15.5 + 15\gamma; \quad (8.52)$$

$$\hat{\sigma}_{11}^T = 19.57 + 0.57\alpha; \quad (8.53)$$

$$\hat{\sigma}_{21}^T = 20 + 2\beta; \quad (8.54)$$

$$\hat{\sigma}_{31}^T = 17.75 + 7.5\gamma; \quad (8.55)$$

$$\hat{\sigma}_{12}^T = 19.75 + .42\alpha; \quad (8.56)$$

$$\hat{\sigma}_{22}^T = 20.25 + 3.75\beta; \quad (8.57)$$

$$\hat{\sigma}_{32}^T = 17 + 10\gamma; \quad (8.58)$$

$$\hat{\sigma}_{13}^C = 14.55 + 0.89\alpha; \quad (8.59)$$

$$\hat{\sigma}_{23}^C = 14.5 + 5\beta; \quad (8.60)$$

$$\hat{\sigma}_{33}^C = 5 + 25\gamma; \quad (8.61)$$

Using total integral values of coefficients, problem (P8.4) can be transformed into

**(P8.5)**

$$\text{Minimize } WT(A_1, A_2) = 100(2\sqrt{2}A_1 + A_2) \quad (8.62)$$

$$\text{Minimize } \delta_u(A_1, A_2; \alpha) = \frac{(22.43 + 0.75\alpha)}{2 \times 10^8 A_1} \quad (8.63)$$

$$\text{Minimize } \delta_u(A_1, A_2; \beta) = \frac{(19.5 + 5\beta)}{2 \times 10^8 A_1} \quad (8.64)$$

$$\text{Minimize } \delta_u(A_1, A_2; \gamma) = \frac{(15.5 + 15\gamma)}{2 \times 10^8 A_1} \quad (8.65)$$

$$\text{Minimize } \delta_v(A_1, A_2; \alpha) = \frac{(22.43 + 0.75\alpha)}{(2 \times 10^8)(A_1 + \sqrt{2}A_2)} \quad (8.66)$$

$$\text{Minimize } \delta_v(A_1, A_2; \beta) = \frac{(19.5 + 5\beta)}{(2 \times 10^8)(A_1 + \sqrt{2}A_2)} \quad (8.67)$$

$$\text{Minimize } \delta_v(A_1, A_2; \gamma) = \frac{(15.5 + 15\gamma)}{(2 \times 10^8)(A_1 + \sqrt{2}A_2)} \quad (8.68)$$

such that

$$\sigma_{11}(A_1, A_2; \alpha) \equiv \frac{(22.43 + 0.75\alpha)(2A_1 + \sqrt{2}A_2)}{(A_1^2 + \sqrt{2}A_1A_2)} \leq 19.57 + 0.57\alpha; \quad (8.69)$$

$$\sigma_{21}(A_1, A_2; \beta) \equiv \frac{(19.5 + 5\beta)(2A_1 + \sqrt{2}A_2)}{(A_1^2 + \sqrt{2}A_1A_2)} \leq 20 + 2\beta; \quad (8.70)$$

$$\sigma_{31}(A_1, A_2; \gamma) \equiv \frac{(15.5 + 15\gamma)(2A_1 + \sqrt{2}A_2)}{(A_1^2 + \sqrt{2}A_1A_2)} \leq 15.5 + 15\gamma; \quad (8.71)$$

$$\sigma_{12}(A_1, A_2; \alpha) \equiv \frac{(22.43 + 0.75\alpha)}{(A_1 + \sqrt{2}A_2)} \leq 19.75 + 0.42\alpha; \quad (8.72)$$

$$\sigma_{22}(A_1, A_2; \beta) \equiv \frac{(19.5 + 5\beta)}{(A_1 + \sqrt{2}A_2)} \leq 20.25 + 3.75\beta; \quad (8.73)$$

$$\sigma_{32}(A_1, A_2; \gamma) \equiv \frac{(15.5 + 15\gamma)}{(A_1 + \sqrt{2}A_2)} \leq 17 + 10\gamma; \quad (8.74)$$

$$\sigma_{13}(A_1, A_2; \alpha) \equiv \frac{(22.43 + 0.75\alpha)A_2}{(\sqrt{2}A_1^2 + 2A_1A_2)} \leq 19.57 + 0.57\alpha; \quad (8.75)$$

$$\sigma_{23}(A_1, A_2; \beta) \equiv \frac{(19.5 + 5\beta)A_2}{(\sqrt{2}A_1^2 + 2A_1A_2)} \leq 20 + 2\beta; \quad (8.76)$$

$$\sigma_{33}(A_1, A_2; \gamma) \equiv \frac{(15.5 + 15\gamma)A_2}{(\sqrt{2}A_1^2 + 2A_1A_2)} \leq 15.5 + 15\gamma; \quad (8.77)$$

$$A_i^{\min} \leq A_i \leq A_i^{\max} \quad i = 1, 2. \quad \alpha, \beta, \gamma \in [0, 1] \quad (8.88)$$

According to step 2 pay-off matrix can be formulated as follows

$WT(A_1, A_2)$	$\delta_u(A_1, A_2; \alpha)$	$\delta_u(A_1, A_2; \beta)$	$\delta_u(A_1, A_2; \gamma)$	$\delta_v(A_1, A_2; \alpha)$	$\delta_v(A_1, A_2; \beta)$	$\delta_v(A_1, A_2; \gamma)$
$A^1$	5.994110	12.52100	12.23464	12.15401	7.229002	7.07121
$A^2$	17.16237	4.486000	4.128718	4.051560	2.419306	2.185012
$A^3$	15.95051	4.519218	3.90	4.051560	3.048520	2.680513
$A^4$	19.14214	4.519218	4.135986	3.10	1.908612	1.284062
$A^5$	19.14214	4.48600	4.128718	4.051560	1.858162	1.678211
$A^6$	19.14214	4.519218	3.90	4.051560	1.908612	1.678211
$A^7$	19.14214	4.519218	4.135986	3.10	1.908612	1.284062

Here  $U_{WT(A_1, A_2)}^F = U_{WT(A_1, A_2)}^T = 19.14214, L_{WT(A_1, A_2)}^F = L_{WT(A_1, A_2)}^T + \varepsilon_{WT(A_1, A_2)} = 5.994110 + \varepsilon_{WT(A_1, A_2)}$ ;

$L_{WT(A_1, A_2)}^I = L_{WT(A_1, A_2)}^T = 5.994110, U_{WT(A_1, A_2)}^I = L_{WT(A_1, A_2)}^T + \xi_{WT(A_1, A_2)} = 5.994110 + \xi_{WT(A_1, A_2)}$

such that  $0 < \varepsilon_{WT(A_1, A_2)}, \xi_{WT(A_1, A_2)} < (19.14214 - 5.994110)$ ;

$$\psi = 4, \theta_{WT(A_1, A_2)} = \frac{6}{U_{WT(A_1, A_2)}^F - L_{WT(A_1, A_2)}^F}, \theta_{WT(A_1, A_2)} = \frac{6}{U_{WT(A_1, A_2)}^F - L_{WT(A_1, A_2)}^F}$$

$$U_{\delta_u(A_1, A_2; \alpha)}^F = U_{\delta_u(A_1, A_2; \alpha)}^T = 12.52100, L_{\delta_u(A_1, A_2; \alpha)}^F = L_{\delta_u(A_1, A_2; \alpha)}^T + \varepsilon_{\delta_u(A_1, A_2; \alpha)} = 4.486000 + \varepsilon_{\delta_u(A_1, A_2; \alpha)};$$

$$L_{\delta_u(A_1, A_2; \alpha)}^I = L_{\delta_u(A_1, A_2; \alpha)}^T = 4.486000, U_{\delta_u(A_1, A_2; \alpha)}^I = L_{\delta_u(A_1, A_2; \alpha)}^T + \xi_{\delta_u(A_1, A_2; \alpha)} = 4.486000 + \xi_{\delta_u(A_1, A_2; \alpha)}$$

such that  $0 < \varepsilon_{\delta_u(A_1, A_2; \alpha)}, \xi_{\delta_u(A_1, A_2; \alpha)} < (12.52100 - 4.48600)$

$$\psi = 4, \theta_{\delta_u(A_1, A_2; \alpha)} = \frac{6}{U_{\delta_u(A_1, A_2; \alpha)}^F - L_{\delta_u(A_1, A_2; \alpha)}^F}, \theta_{\delta_u(A_1, A_2; \alpha)} = \frac{6}{U_{\delta_u(A_1, A_2; \alpha)}^F - L_{\delta_u(A_1, A_2; \alpha)}^F}$$

$$U_{\delta_u(A_1, A_2; \beta)}^F = U_{\delta_u(A_1, A_2; \beta)}^T = 12.23464, L_{\delta_u(A_1, A_2; \beta)}^F = L_{\delta_u(A_1, A_2; \beta)}^T + \varepsilon_{\delta_u(A_1, A_2; \beta)} = 3.90 + \varepsilon_{\delta_u(A_1, A_2; \beta)};$$

$$L_{\delta_u(A_1, A_2; \beta)}^I = L_{\delta_u(A_1, A_2; \beta)}^T = 3.90, U_{\delta_u(A_1, A_2; \beta)}^I = L_{\delta_u(A_1, A_2; \beta)}^T + \xi_{\delta_u(A_1, A_2; \beta)} = 3.90 + \xi_{\delta_u(A_1, A_2; \beta)}$$

such that  $0 < \varepsilon_{\delta_u(A_1, A_2; \beta)}, \xi_{\delta_u(A_1, A_2; \beta)} < (12.23464 - 3.90)$

$$\psi = 4, \theta_{\delta_u(A_1, A_2; \beta)} = \frac{6}{U_{\delta_u(A_1, A_2; \beta)}^F - L_{\delta_u(A_1, A_2; \beta)}^F}, \theta_{\delta_u(A_1, A_2; \beta)} = \frac{6}{U_{\delta_u(A_1, A_2; \beta)}^F - L_{\delta_u(A_1, A_2; \beta)}^F}$$

$$U_{\delta_u(A_1, A_2; \gamma)}^F = U_{\delta_u(A_1, A_2; \gamma)}^T = 12.15401, L_{\delta_u(A_1, A_2; \gamma)}^F = L_{\delta_u(A_1, A_2; \gamma)}^T + \varepsilon_{\delta_u(A_1, A_2; \gamma)} = 3.1 + \varepsilon_{\delta_u(A_1, A_2; \gamma)};$$

$$L_{\delta_u(A_1, A_2; \gamma)}^I = L_{\delta_u(A_1, A_2; \gamma)}^T = 3.10, U_{\delta_u(A_1, A_2; \gamma)}^I = L_{\delta_u(A_1, A_2; \gamma)}^T + \xi_{\delta_u(A_1, A_2; \gamma)} = 3.10 + \xi_{\delta_u(A_1, A_2; \gamma)}$$

such that  $0 < \varepsilon_{\delta_u(A_1, A_2; \gamma)}, \xi_{\delta_u(A_1, A_2; \gamma)} < (12.15401 - 3.10)$

$$\psi = 4, \theta_{\delta_u(A_1, A_2; \gamma)} = \frac{6}{U_{\delta_u(A_1, A_2; \gamma)}^F - L_{\delta_u(A_1, A_2; \gamma)}^F}, \theta_{\delta_u(A_1, A_2; \gamma)} = \frac{6}{U_{\delta_u(A_1, A_2; \gamma)}^F - L_{\delta_u(A_1, A_2; \gamma)}^F}$$

$$U_{\delta_v(A_1, A_2; \alpha)}^F = U_{\delta_v(A_1, A_2; \alpha)}^T = 7.229002, L_{\delta_v(A_1, A_2; \alpha)}^F = L_{\delta_v(A_1, A_2; \alpha)}^T + \varepsilon_{\delta_v(A_1, A_2; \alpha)} = 1.858162 + \varepsilon_{\delta_v(A_1, A_2; \alpha)};$$

$$L_{\delta_v(A_1, A_2; \alpha)}^I = L_{\delta_v(A_1, A_2; \alpha)}^T = 1.858162, U_{\delta_v(A_1, A_2; \alpha)}^I = L_{\delta_v(A_1, A_2; \alpha)}^T + \xi_{\delta_v(A_1, A_2; \alpha)} = 1.858162 + \xi_{\delta_v(A_1, A_2; \alpha)}$$

such that  $0 < \varepsilon_{\delta_v(A_1, A_2; \alpha)}, \xi_{\delta_v(A_1, A_2; \alpha)} < (7.229002 - 1.858162)$

$$\psi = 4, \theta_{\delta_v(A_1, A_2; \alpha)} = \frac{6}{U_{\delta_v(A_1, A_2; \alpha)}^F - L_{\delta_v(A_1, A_2; \alpha)}^F}, \theta_{\delta_v(A_1, A_2; \alpha)} = \frac{6}{U_{\delta_v(A_1, A_2; \alpha)}^F - L_{\delta_v(A_1, A_2; \alpha)}^F}$$

$$U_{\delta_v(A_1, A_2; \beta)}^F = U_{\delta_v(A_1, A_2; \beta)}^T = 7.063671, L_{\delta_v(A_1, A_2; \beta)}^F = L_{\delta_v(A_1, A_2; \beta)}^T + \varepsilon_{\delta_v(A_1, A_2; \beta)} = 1.615433 + \varepsilon_{\delta_v(A_1, A_2; \beta)};$$

$$L_{\delta_v(A_1, A_2; \beta)}^I = L_{\delta_v(A_1, A_2; \beta)}^T = 1.615433, U_{\delta_v(A_1, A_2; \beta)}^I = L_{\delta_v(A_1, A_2; \beta)}^T + \xi_{\delta_v(A_1, A_2; \beta)} = 1.615433 + \xi_{\delta_v(A_1, A_2; \beta)}$$

such that  $0 < \varepsilon_{\delta_v(A_1, A_2; \beta)}, \xi_{\delta_v(A_1, A_2; \beta)} < (7.063671 - 1.615433)$

$$\psi = 4, \theta_{\delta_v(A_1, A_2; \beta)} = \frac{6}{U_{\delta_v(A_1, A_2; \beta)}^F - L_{\delta_v(A_1, A_2; \beta)}^F}, \theta_{\delta_v(A_1, A_2; \beta)} = \frac{6}{U_{\delta_v(A_1, A_2; \beta)}^F - L_{\delta_v(A_1, A_2; \beta)}^F}$$

$$U_{\delta_v(A_1, A_2; \gamma)}^F = U_{\delta_v(A_1, A_2; \gamma)}^T = 7.07121, L_{\delta_v(A_1, A_2; \gamma)}^F = L_{\delta_v(A_1, A_2; \gamma)}^T + \varepsilon_{\delta_v(A_1, A_2; \gamma)} = 1.284062 + \varepsilon_{\delta_v(A_1, A_2; \gamma)};$$

$$L_{\delta_v(A_1, A_2; \gamma)}^I = L_{\delta_v(A_1, A_2; \gamma)}^T = 1.284062, U_{\delta_v(A_1, A_2; \gamma)}^I = L_{\delta_v(A_1, A_2; \gamma)}^T + \xi_{\delta_v(A_1, A_2; \gamma)} = 1.284062 + \xi_{\delta_v(A_1, A_2; \gamma)}$$

such that  $0 < \varepsilon_{\delta_v(A_1, A_2; \gamma)}, \xi_{\delta_v(A_1, A_2; \gamma)} < (7.07121 - 1.284062)$

$$\psi = 4, \theta_{\delta_v(A_1, A_2; \gamma)} = \frac{6}{U_{\delta_v(A_1, A_2; \gamma)}^F - L_{\delta_v(A_1, A_2; \gamma)}^F}, \theta_{\delta_v(A_1, A_2; \gamma)} = \frac{6}{U_{\delta_v(A_1, A_2; \gamma)}^F - L_{\delta_v(A_1, A_2; \gamma)}^F}$$

Here nonlinear truth, indeterminacy and falsity membership function of objectives  $WT(A_1, A_2)$ ;

$\delta_u(A_1, A_2; \alpha)$ ;  $\delta_u(A_1, A_2; \beta)$ ;  $\delta_u(A_1, A_2; \gamma)$  and  $\delta_v(A_1, A_2; \alpha)$ ;  $\delta_v(A_1, A_2; \beta)$ ;  $\delta_v(A_1, A_2; \gamma)$  are defined for  $T = 2$  as follows

$$T_{WT(A_1, A_2)}(WT(A_1, A_2)) = \begin{cases} 1 & \text{if } WT(A_1, A_2) \leq 5.994110 \\ 1 - \exp\left\{-4 \left(\frac{19.14214 - WT(A_1, A_2)}{19.14214 - 5.994110}\right)\right\} & \text{if } 5.994110 \leq WT(A_1, A_2) \leq 19.14214 \\ 0 & \text{if } WT(A_1, A_2) \geq 19.14214 \end{cases} \quad (8.89)$$

$$I_{WT(A_1, A_2)}(WT(A_1, A_2)) = \begin{cases} 1 & \text{if } WT(A_1, A_2) \leq 5.994110 + \xi_{WT(A_1, A_2)} \\ \exp\left\{\frac{19.14214 - WT(A_1, A_2)}{19.14214 - (5.994110 + \xi_{WT(A_1, A_2)})}\right\} & \text{if } 5.994110 + \xi_{WT(A_1, A_2)} \leq WT(A_1, A_2) \leq 19.14214 \\ 0 & \text{if } WT(A_1, A_2) \geq 19.14214 \end{cases} \quad (8.90)$$

$$F_{WT(A_1, A_2)}(WT(A_1, A_2)) = \begin{cases} 0 & \text{if } WT(A_1, A_2) \leq 5.994110 + \varepsilon_{WT(A_1, A_2)} \\ \frac{1}{2} + \frac{1}{2} \tanh\left\{\left(WT(A_1, A_2) - \frac{19.14214 + 5.994110 + \varepsilon_{WT(A_1, A_2)}}{2}\right)\theta_{WT(A_1, A_2)}\right\} & \text{if } 5.994110 + \varepsilon_{WT(A_1, A_2)} \leq WT(A_1, A_2) \leq 19.14214 \\ 1 & \text{if } WT(A_1, A_2) \geq 19.14214 \end{cases} \quad (8.91)$$

$$T_{\delta_u(A_1, A_2; \alpha)}(\delta_u(A_1, A_2; \alpha)) = \begin{cases} 1 & \text{if } \delta_u(A_1, A_2; \alpha) \leq 4.48600 \\ 1 - \exp\left\{-4 \left(\frac{12.52100 - \delta_u(A_1, A_2; \alpha)}{12.52100 - 4.48600}\right)\right\} & \text{if } 4.48600 \leq \delta_u(A_1, A_2; \alpha) \leq 12.52100 \\ 0 & \text{if } \delta_u(A_1, A_2; \alpha) \geq 12.52100 \end{cases} \quad (8.92)$$

$$I_{\delta_u(A_1, A_2; \alpha)}(\delta_u(A_1, A_2; \alpha)) = \begin{cases} 1 & \text{if } \delta_u(A_1, A_2; \alpha) \leq 4.48600 + \xi_{\delta_u(A_1, A_2; \alpha)} \\ \exp\left\{\frac{12.52100 - \delta_u(A_1, A_2; \alpha)}{12.52100 - (4.48600 + \xi_{\delta_u(A_1, A_2; \alpha)})}\right\} & \text{if } 4.48600 + \xi_{\delta_u(A_1, A_2; \alpha)} \leq \delta_u(A_1, A_2; \alpha) \leq 12.52100 \\ 0 & \text{if } \delta_u(A_1, A_2; \alpha) \geq 12.52100 \end{cases} \quad (8.93)$$

$$F_{\delta_u(A_1, A_2; \alpha)}(\delta_u(A_1, A_2; \alpha)) = \begin{cases} 0 & \text{if } \delta_u(A_1, A_2; \alpha) \leq 4.48600 + \varepsilon_{\delta_u(A_1, A_2; \alpha)} \\ \frac{1}{2} + \frac{1}{2} \tanh\left\{\left(\delta_u(A_1, A_2; \alpha) - \frac{12.52100 + 4.48600 + \varepsilon_{\delta_u(A_1, A_2; \alpha)}}{2}\right)\theta_{\delta_u(A_1, A_2; \alpha)}\right\} & \text{if } 4.48600 + \varepsilon_{\delta_u(A_1, A_2; \alpha)} \leq \delta_u(A_1, A_2; \alpha) \leq 12.52100 \\ 1 & \text{if } \delta_u(A_1, A_2; \alpha) \geq 12.52100 \end{cases} \quad (8.94)$$

$$T_{\delta_u(A_1, A_2; \beta)}(\delta_u(A_1, A_2; \beta)) = \begin{cases} 1 & \text{if } \delta_u(A_1, A_2; \beta) \leq 3.90 \\ 1 - \exp\left\{-4\left(\frac{12.23464 - \delta_u(A_1, A_2; \beta)}{12.23464 - 3.90}\right)\right\} & \text{if } 3.90 \leq \delta_u(A_1, A_2; \beta) \leq 12.23464 \\ 0 & \text{if } \delta_u(A_1, A_2; \beta) \geq 3.90 \end{cases} \quad (8.95)$$

$$I_{\delta_u(A_1, A_2; \beta)}(\delta_u(A_1, A_2; \beta)) = \begin{cases} 1 & \text{if } \delta_u(A_1, A_2; \beta) \leq 3.90 + \xi_{\delta_u(A_1, A_2; \beta)} \\ \exp\left\{\frac{12.23464 - \delta_u(A_1, A_2; \beta)}{12.23464 - (3.90 + \xi_{\delta_u(A_1, A_2; \beta)})}\right\} & \text{if } 3.90 + \xi_{\delta_u(A_1, A_2; \beta)} \leq \delta_u(A_1, A_2; \beta) \leq 12.23464 \\ 0 & \text{if } \delta_u(A_1, A_2; \beta) \geq 12.23464 \end{cases} \quad (8.96)$$

$$F_{\delta_u(A_1, A_2; \beta)}(\delta_u(A_1, A_2; \beta)) = \begin{cases} 0 & \text{if } \delta_u(A_1, A_2; \beta) \leq 3.90 + \varepsilon_{\delta_u(A_1, A_2; \beta)} \\ \frac{1}{2} + \frac{1}{2} \tanh\left\{\left(\delta_u(A_1, A_2; \beta) - \frac{12.23464 + 3.90 + \varepsilon_{\delta_u(A_1, A_2; \beta)}}{2}\right)\theta_{\delta_u(A_1, A_2; \beta)}\right\} & \text{if } 3.90 + \varepsilon_{\delta_u(A_1, A_2; \beta)} \leq \delta_u(A_1, A_2; \beta) \leq 12.23464 \\ 1 & \text{if } \delta_u(A_1, A_2; \beta) \geq 12.23464 \end{cases} \quad (8.97)$$

and

$$T_{\delta_u(A_1, A_2; \gamma)}(\delta_u(A_1, A_2; \gamma)) = \begin{cases} 1 & \text{if } \delta_u(A_1, A_2; \gamma) \leq 3.10 \\ 1 - \exp\left\{-4\left(\frac{12.15401 - \delta_u(A_1, A_2; \gamma)}{12.15401 - 3.10}\right)\right\} & \text{if } 3.10 \leq \delta_u(A_1, A_2; \gamma) \leq 12.15401 \\ 0 & \text{if } \delta_u(A_1, A_2; \gamma) \geq 12.15401 \end{cases} \quad (8.98)$$

$$I_{\delta_u(A_1, A_2; \gamma)}(\delta_u(A_1, A_2; \gamma)) = \begin{cases} 1 & \text{if } \delta_u(A_1, A_2; \gamma) \leq 3.10 + \xi_{\delta_u(A_1, A_2; \gamma)} \\ \exp\left\{\frac{12.15401 - \delta_u(A_1, A_2; \gamma)}{12.15401 - (3.10 + \xi_{\delta_u(A_1, A_2; \gamma)})}\right\} & \text{if } 3.10 + \xi_{\delta_u(A_1, A_2; \gamma)} \leq \delta_u(A_1, A_2; \gamma) \leq 12.15401 \\ 0 & \text{if } \delta_u(A_1, A_2; \gamma) \geq 12.15401 \end{cases} \quad (8.99)$$

$$F_{\delta_u(A_1, A_2; \gamma)}(\delta_u(A_1, A_2; \gamma)) = \begin{cases} 0 & \text{if } \delta_u(A_1, A_2; \gamma) \leq 3.10 + \varepsilon_{\delta_u(A_1, A_2; \gamma)} \\ \frac{1}{2} + \frac{1}{2} \tanh\left\{\left(\delta_u(A_1, A_2; \gamma) - \frac{12.15401 + 3.10 + \varepsilon_{\delta_u(A_1, A_2; \gamma)}}{2}\right)\theta_{\delta_u(A_1, A_2; \gamma)}\right\} & \text{if } 3.10 + \varepsilon_{\delta_u(A_1, A_2; \gamma)} \leq \delta_u(A_1, A_2; \gamma) \leq 12.15401 \\ 1 & \text{if } \delta_u(A_1, A_2; \gamma) \geq 12.15401 \end{cases} \quad (8.100)$$

$$T_{\delta_v(A_1, A_2; \alpha)}(\delta_v(A_1, A_2; \alpha)) = \begin{cases} 1 & \text{if } \delta_v(A_1, A_2; \alpha) \leq 1.858162 \\ 1 - \exp\left\{-4\left(\frac{7.229002 - \delta_v(A_1, A_2; \alpha)}{7.229002 - 1.858162}\right)\right\} & \text{if } 1.858162 \leq \delta_v(A_1, A_2; \alpha) \leq 7.229002 \\ 0 & \text{if } \delta_v(A_1, A_2; \alpha) \geq 1.858162 \end{cases} \quad (8.101)$$

$$I_{\delta_v(A_1, A_2; \alpha)}(\delta_v(A_1, A_2; \alpha)) = \begin{cases} 1 & \text{if } \delta_v(A_1, A_2; \alpha) \leq 1.858162 + \xi_{\delta_v(A_1, A_2; \alpha)} \\ \exp\left\{\frac{7.229002 - \delta_v(A_1, A_2; \alpha)}{7.229002 - (1.858162 + \xi_{\delta_v(A_1, A_2; \alpha)})}\right\} & \text{if } 1.858162 + \xi_{\delta_v(A_1, A_2; \alpha)} \leq \delta_v(A_1, A_2; \alpha) \leq 7.229002 \\ 0 & \text{if } \delta_v(A_1, A_2; \alpha) \geq 7.229002 \end{cases} \quad (8.102)$$

$$F_{\delta_v(A_1, A_2; \alpha)}(\delta_v(A_1, A_2; \alpha)) = \begin{cases} 0 & \text{if } \delta_v(A_1, A_2; \alpha) \leq 1.858162 + \varepsilon_{\delta_v(A_1, A_2; \alpha)} \\ \frac{1}{2} + \frac{1}{2} \tanh\left\{\left(\delta_v(A_1, A_2; \alpha) - \frac{7.229002 + 1.858162 + \varepsilon_{\delta_v(A_1, A_2; \alpha)}}{2}\right)\theta_{\delta_v(A_1, A_2; \alpha)}\right\} & \text{if } 1.858162 + \varepsilon_{\delta_v(A_1, A_2; \alpha)} \leq \delta_v(A_1, A_2; \alpha) \leq 7.229002 \\ 1 & \text{if } \delta_v(A_1, A_2; \alpha) \geq 7.229002 \end{cases} \quad (8.103)$$

$$T_{\delta_v(A_1, A_2; \beta)}(\delta_v(A_1, A_2; \beta)) = \begin{cases} 1 & \text{if } \delta_v(A_1, A_2; \beta) \leq 1.615433 \\ 1 - \exp\left\{-4\left(\frac{7.063671 - \delta_v(A_1, A_2; \beta)}{7.063671 - 1.615433}\right)\right\} & \text{if } 1.615433 \leq \delta_v(A_1, A_2; \beta) \leq 7.063671 \\ 0 & \text{if } \delta_v(A_1, A_2; \beta) \geq 1.615433 \end{cases} \quad (8.104)$$

$$I_{\delta_v(A_1, A_2; \beta)}(\delta_v(A_1, A_2; \beta)) = \begin{cases} 1 & \text{if } \delta_v(A_1, A_2; \beta) \leq 1.615433 + \xi_{\delta_v(A_1, A_2; \beta)} \\ \exp\left\{\frac{7.063671 - \delta_v(A_1, A_2; \beta)}{7.063671 - (1.615433 + \xi_{\delta_v(A_1, A_2; \beta)})}\right\} & \text{if } 1.615433 + \xi_{\delta_v(A_1, A_2; \beta)} \leq \delta_v(A_1, A_2; \beta) \leq 7.063671 \\ 0 & \text{if } \delta_v(A_1, A_2; \beta) \geq 7.063671 \end{cases} \quad (8.105)$$

$$F_{\delta_v(A_1, A_2; \beta)}(\delta_v(A_1, A_2; \beta)) = \begin{cases} 0 & \text{if } \delta_v(A_1, A_2; \beta) \leq 1.615433 + \varepsilon_{\delta_v(A_1, A_2; \beta)} \\ \frac{1}{2} + \frac{1}{2} \tanh\left\{\left(\delta_v(A_1, A_2; \beta) - \frac{7.063671 + 1.615433 + \varepsilon_{\delta_v(A_1, A_2; \beta)}}{2}\right)\theta_{\delta_v(A_1, A_2; \beta)}\right\} & \text{if } 1.615433 + \varepsilon_{\delta_v(A_1, A_2; \beta)} \leq \delta_v(A_1, A_2; \beta) \leq 7.063671 \\ 1 & \text{if } \delta_v(A_1, A_2; \beta) \geq 7.063671 \end{cases} \quad (8.106)$$

$$T_{\delta_v(A_1, A_2; \gamma)}(\delta_v(A_1, A_2; \gamma)) = \begin{cases} 1 & \text{if } \delta_v(A_1, A_2; \gamma) \leq 1.284062 \\ 1 - \exp\left\{-4\left(\frac{7.07121 - \delta_v(A_1, A_2; \gamma)}{7.07121 - 1.284062}\right)\right\} & \text{if } 1.284062 \leq \delta_v(A_1, A_2; \gamma) \leq 7.07121 \\ 0 & \text{if } \delta_v(A_1, A_2; \gamma) \geq 1.284062 \end{cases} \quad (8.107)$$

$$I_{\delta_v(A_1, A_2; \gamma)}(\delta_v(A_1, A_2; \gamma)) = \begin{cases} 1 & \text{if } \delta_v(A_1, A_2; \gamma) \leq 1.284062 + \xi_{\delta_v(A_1, A_2; \gamma)} \\ \exp\left\{\frac{7.07121 - \delta_v(A_1, A_2; \gamma)}{7.07121 - (1.284062 + \xi_{\delta_v(A_1, A_2; \gamma)})}\right\} & \text{if } 1.284062 + \xi_{\delta_v(A_1, A_2; \gamma)} \leq \delta_v(A_1, A_2; \gamma) \leq 7.07121 \\ 0 & \text{if } \delta_v(A_1, A_2; \gamma) \geq 7.07121 \end{cases} \quad (8.108)$$

$$F_{\delta_v(A_1, A_2; \gamma)}(\delta_v(A_1, A_2; \gamma)) = \begin{cases} 0 & \text{if } \delta_v(A_1, A_2; \gamma) \leq 1.284062 + \varepsilon_{\delta_v(A_1, A_2; \gamma)} \\ \frac{1}{2} + \frac{1}{2} \tanh\left\{\left(\delta_v(A_1, A_2; \gamma) - \frac{7.07121 + 1.284062 + \varepsilon_{\delta_v(A_1, A_2; \gamma)}}{2}\right)\theta_{\delta_v(A_1, A_2; \gamma)}\right\} & \text{if } 1.284062 + \varepsilon_{\delta_v(A_1, A_2; \gamma)} \leq \delta_v(A_1, A_2; \gamma) \leq 7.07121 \\ 1 & \text{if } \delta_v(A_1, A_2; \gamma) \geq 7.07121 \end{cases} \quad (8.109)$$



Using fuzzy, Intuitionistic, Neutrosophic Probabilistic Operator for truth; truth, falsity and truth, indeterminacy , falsity membership function respectively the optimal results of model (P8.5) can be obtained and is given in Table 8.1.

**Table 8.1 Optimal weight and deflection for**  $\varepsilon_{WT(A_1, A_2)}, \xi_{WT(A_1, A_2)} = 1.3;$

$$\varepsilon_{\delta_u(A_1, A_2; \alpha)}, \xi_{\delta_u(A_1, A_2; \alpha)} = 0.8; \varepsilon_{\delta_u(A_1, A_2; \beta)}, \xi_{\delta_u(A_1, A_2; \beta)} = 0.83; \varepsilon_{\delta_u(A_1, A_2; \gamma)}, \xi_{\delta_u(A_1, A_2; \gamma)} = 0.9;$$

$$\varepsilon_{\delta_v(A_1, A_2; \alpha)}, \xi_{\delta_v(A_1, A_2; \alpha)} = 0.53; \varepsilon_{\delta_v(A_1, A_2; \beta)}, \xi_{\delta_v(A_1, A_2; \beta)} = 0.54; \varepsilon_{\delta_v(A_1, A_2; \gamma)}, \xi_{\delta_v(A_1, A_2; \gamma)} = 0.57;$$

Method	$A_1^* \times 10^{-4} m^2$	$A_2^* \times 10^{-4} m^2$	$WT^* \times 10^2 KN$	$\delta_u^* \times 10^{-7} m$	$\delta_v^* \times 10^{-7} m$
Fuzzy Max-Min Operator	2.425445	1.568392	8.428587	0.5830738	0.3045585
Fuzzy Probabilistic operator	2.299305	4.006269	10.50968	8.698282	2.510978
Intuitionistic Probabilistic Operator	1.495007	2.604875	6.833394	13.37785	3.861852
Neutrosophic Probabilistic Operator	4.903401	4.807390	18.67630	4.078801	1.709098

From the Table 8.1. we may arrive to the conclusion that the weight is minimized when we have solved the model in intuitionistic optimization technique. As an explanation we can say in IFO we usually minimize non membership functions and maximize membership functions simultaneously. So it gives better result compare to FO where we only consider membership function for minimization. But as degree of acceptance is partially included in hesitancy and we minimize it in NSO it has given higher value than the result obtained in intuitionistic optimization.

## 8.4 Conclusion

In this chapter we have proposed a method to solve multi-objective structural model in neutrosophic environment. Here generalized neutrosophic number has been considered for applied load and stress parameter. The said model is solved by neutrosophic probabilistic operator and result is compared with fuzzy as well as intuitionistic probabilistic operator. The weight of the truss is more optimized by intuitionistic optimization technique. The main advantage of the described method is that it allows us

to overcome the actual limitations in a problem where impreciseness of supplied data are involved during the specification of the objectives. This approximation method can be applied to optimize different models in various fields of engineering and sciences.

# CHAPTER 9

---

## Optimization of Welded Beam with Imprecise Load and Stress by Parameterized Neutrosophic Optimization Technique

---

Welding is a process of joining metallic parts by heating to a suitable temperature with or without the application of pressure. In this chapter we have investigated a problem which is a simplified example of many complex design issues arising in structural engineering. The problem is dealing with designing the form of steel beams and with connecting them to form complex structure like bridges, buildings etc. The problem of designing an optimum welded beam consists of dimensioning a welded steel beam and the welding length so as to minimize its cost subject to constraints on shear stress, bending stress in the beam, buckling load on the bar, the end the deflection on the beam and the side constraints. Most importantly the design of welded beam should preferably be economical and durable one. Since decades, deterministic optimization has been widely used in practice for optimizing welded connection design. These include mathematical traditional optimization algorithms (Ragsdell & Phillips [90]), GA-based methods (Deb [40], Deb [37], Coello [14], Coello [25]), particle swarm optimization (Reddy [59]), harmony search method (Lee & Geem [67]), and Big-Bang Big-Crunch (BB-BC) algorithm (O. Hasançebi, [65]), subset simulation (Li [73]), improved harmony search algorithm (Mahadavi [72]), as methods used to solve this problem. All these deterministic optimizations aim to search the optimum solution under given constraints without consideration of uncertainties. So, while a deterministic optimization approach is unable to handle structural performances such as imprecise stresses and deflection etc. due to the presence of impreciseness, to get rid of such problem Fuzzy Set(FS)(Zadeh, [133]), Intuitionistic Fuzzy Set(IFS) (Atanassov,[1]) Neutrosophic Set(NS)(Smarandache [99]) play great roles. In IFS theory we usually consider degree of acceptance, and degree of rejection where as we consider only membership function in FS. Sarkar [104] optimize two bar truss design with imprecise load and stress in Intuitionistic Fuzzy(IF) environment calculating total integral values of Triangular Intuitionistic Fuzzy Number(TIFN). Shu [108] applied TIFN to fault tree analysis on printed board circuit assembly .P.Grzegorzewski et.al [48],H.B.Mitchell et.al [75],G.Nayagam et.al [78],H.M.Nehi et.al [79],S.Rezvani et.al [92] have been employed concept of

Intuitionistic Fuzzy Number (IFN) in Multi-Attribute Decision Making (MADM) problem. So indeterminate information should be considered in decision making process. A few research work has been done on Neutrosophic Optimization (NSO) in the field of structural optimization. So to deal with different impreciseness on load, stresses and deflection, we have been motivated to incorporate the concept of Neutrosophic Number(NN) in this problem, and have developed NSO algorithm to optimize the optimum design in imprecise environment. In IFN indeterminate information is partially lost, as hesitant information is taken in consideration by default. So indeterminate information should be considered in decision making process. Smarandache [94] defined neutrosophic set that could handle indeterminate and inconsistent information. In neutrosophic sets indeterminacy is quantified explicitly with truth membership, indeterminacy membership and falsity membership function which are independent. Wang et.al [120] define Single Valued Neutrosophic Set(SVNS) which represents imprecise, incomplete, indeterminate, inconsistent information. Thus taking the universe as a real line we can develop the concept of single valued neutrosophic number as special case of neutrosophic sets. These numbers are able to express ill-known quantity with uncertain numerical value in decision making problem. We define generalized triangular neutrosophic number and nearest interval approximation of this number. Then using parametric interval valued function for approximated interval number of NN we solve WBD problem in neutrosophic environment. This paper develops optimization algorithm using max-min operator in neutrosophic environment to optimize the cost of welding, while the maximum shear stress in the weld group, maximum bending stress in the beam, and buckling load of the beam and deflection at the tip of a welded steel beam have been considered as constraints. Here parametric interval valued function of Generalized Triangular Neutrosophic Number(GTNN) have been considered for applied load, stress and deflection. The present study investigates computational algorithm for solving single-objective nonlinear programming problem by parametric NSO approach.

## **9.1 General Formulation of Single-Objective Welded Beam Design**

In sizing optimization problems, the aim is to minimize single objective function, usually the cost of the structure under certain behavioural constraints which are displacement or stresses. The design variables are most frequently chosen to be dimensions of the height, length, depth and width of the structures. Due to fabrications limitations the design variables are not

continuous but discrete for belongingness of cross-sections to a certain set. A discrete structural optimization problem can be formulated in the following form

**(P9.1)**

$$\text{Minimize } C(X) \quad (9.1)$$

$$\text{subject to } \sigma_i(X) \leq [\sigma_i], i = 1, 2, \dots, m \quad (9.2)$$

$$X_j \in R^d, \quad j = 1, 2, \dots, n \quad (9.3)$$

where  $C(X)$  represents cost function,  $\sigma_i(X)$  is the behavioural constraints and  $[\sigma_i(X)]$  denotes the maximum allowable value, 'm' and 'n' are the number of constraints and design variables respectively. A given set of discrete value is expressed by  $R^d$  and in this chapter objective function is taken as

$$C(X) = \sum_{t=1}^T c_t \prod_{n=1}^m x_n^{t_n} \quad (9.4)$$

and constraint are chosen to be stress of structures as follows

$$\sigma_i(X) \lesssim \sigma_i \text{ with allowable tolerance } \sigma_i^0 \text{ for } i = 1, 2, \dots, m \quad (9.5)$$

The deflection of the structure as follows

$$\delta(X) \lesssim \delta_{\max} \text{ with allowable tolerance } \delta_{\max}^0 \quad (9.6)$$

Where  $c_t$  is the cost coefficient of  $t^{\text{th}}$  side and  $x_n$  is the  $n^{\text{th}}$  design variable respectively,  $m$  is the number of structural element,  $\sigma_i$  and  $\sigma_i^0$   $\delta_{\max}^0$  are the  $i^{\text{th}}$  stress, allowable stress and allowable deflection respectively.

## 9.2NSO Technique to Optimize Parametric Single-Objective Welded Beam Design(SOWBD)

The parametric WBD problem can be formulated as

**(P9.2)**

$$\text{Minimize } C(X; s) \quad (9.7)$$

$$\text{subject to } \sigma_i(X; s) \leq [\sigma_i(s)], i = 1, 2, \dots, m \quad (9.8)$$

$$X_j \in R^d, \quad j=1,2,\dots,n \quad (9.9)$$

$$X > 0; s \in [0,1] \quad (9.10)$$

where  $C(X;s)$  represents cost function,  $\sigma_i(X;s)$  is the behavioural constraints and  $[\sigma_i(X;s)]$  denotes the maximum allowable value, 'm' and 'n' are the number of constraints and design variables respectively. A given set of discrete value is expressed by  $R^d$  and in this chapter objective function is taken as

$$C(X;s) = \sum_{t=1}^T c_t(s) \prod_{n=1}^m x_n^{t_n} \quad (9.11)$$

and constraint are chosen to be stress of structures as follows

$$\sigma_i(X;s) \leq^n \sigma_i(s) \text{ with allowable tolerance } \sigma_i^0(s) \text{ for } i=1,2,\dots,m \quad (9.12)$$

The deflection of the structure as follows

$$\delta(X;s) \leq^n \delta_{\max}(s) \text{ with allowable tolerance } \delta_{\max}^0(s) \quad (9.13)$$

Where  $c_i$  is the cost coefficient of  $t^{\text{th}}$  side and  $x_n$  is the  $n^{\text{th}}$  design variable respectively,  $m$  is the number of structural element,  $\sigma_i$  and  $\sigma_i^0(s)$   $\delta_{\max}^0(s)$  are the  $i^{\text{th}}$  stress, allowable stress and allowable deflection respectively.

To solve the SOWBP (P9.2), step 1 of 1.40 is used and let  $U_{C(X;s)}^T, U_{C(X;s)}^I, U_{C(X;s)}^F$  be the upper bounds of truth, indeterminacy, falsity function for the objective respectively and  $L_{C(X;s)}^T, L_{C(X;s)}^I, L_{C(X;s)}^F$  be the lower bound of truth, indeterminacy, falsity membership functions of objective respectively then

$$U_{C(X;s)}^T = \max\{C(X^1;s), C(X^2;s)\}, \quad (9.14)$$

$$L_{C(X;s)}^T = \min\{C(X^1;s), C(X^2;s)\}, \quad (9.15)$$

$$U_{C(X;s)}^F = U_{C(X;s)}^T, \quad (9.16)$$

$$L_{C(X;s)}^F = L_{C(X;s)}^T + \varepsilon_{C(X;s)} \text{ where } 0 < \varepsilon_{C(X;s)} < (U_{C(X;s)}^T - L_{C(X;s)}^T) \quad (9.17)$$

$$L_{C(X;s)}^I = L_{C(X;s)}^T, \quad (9.18)$$

$$U_{C(X;s)}^I = L_{C(X;s)}^T + \xi_{C(X;s)} \text{ where } 0 < \xi_{C(X;s)} < (U_{C(X;s)}^T - L_{C(X;s)}^T) \quad (9.19)$$

Let the linear membership function for objective be

$$T_{C(X;s)}(C(X;s)) = \begin{cases} 1 & \text{if } C(X;s) \leq L_{C(X;s)}^T \\ \left( \frac{U_{C(X;s)}^T - C(X;s)}{U_{C(X;s)}^T - L_{C(X;s)}^T} \right) & \text{if } L_{C(X;s)}^T \leq C(X;s) \leq U_{C(X;s)}^T \\ 0 & \text{if } C(X;s) \geq U_{C(X;s)}^T \end{cases} \quad (9.20)$$

$$I_{C(X;s)}(C(X;s)) = \begin{cases} 1 & \text{if } C(X;s) \leq L_{C(X;s)}^I \\ \left( \frac{U_{C(X;s)}^I - C(X;s)}{U_{C(X;s)}^I - L_{C(X;s)}^I} \right) & \text{if } L_{C(X;s)}^I \leq C(X;s) \leq U_{C(X;s)}^I \\ 0 & \text{if } C(X;s) \geq U_{C(X;s)}^I \end{cases} \quad (9.21)$$

$$F_{C(X;s)}(C(X;s)) = \begin{cases} 0 & \text{if } C(X;s) \leq L_{C(X;s)}^F \\ \frac{C(X;s) - L_{C(X;s)}^F}{U_{C(X;s)}^F - L_{C(X;s)}^F} & \text{if } L_{C(X;s)}^F \leq C(X;s) \leq U_{C(X;s)}^F \\ 1 & \text{if } C(X;s) \geq U_{C(X;s)}^F \end{cases} \quad (9.22)$$

and constraints be

$$T_{g_j(x;s)}(g_j(x;s)) = \begin{cases} 1 & \text{if } g_j(x;s) \leq b_j(s) \\ \left( \frac{b_j(s) + b_j^0(s) - g_j(x;s)}{b_j^0(s)} \right) & \text{if } b_j(s) \leq g_j(x;s) \leq b_j(s) + b_j^0(s) \\ 0 & \text{if } g_j(x;s) \geq b_j^0(s) \end{cases} \quad (9.23)$$

$$I_{g_j(x;s)}(g_j(x;s)) = \begin{cases} 1 & \text{if } g_j(x;s) \leq b_j(s) \\ \frac{(b_j(s) + \xi_{g_j(x;s)}) - g_j(x;s)}{\xi_{g_j(x;s)}} & \text{if } b_j(s) \leq g_j(x;s) \leq b_j(s) + \xi_{g_j(x;s)} \\ 0 & \text{if } g_j(x;s) \geq b_j(s) + \xi_{g_j(x;s)} \end{cases} \quad (9.24)$$

$$F_{g_j(x;s)}(g_j(x;s)) = \begin{cases} 0 & \text{if } g_j(x;s) \leq b_j(s) + \varepsilon_{g_j(x;s)} \\ \frac{g_j(x;s) - b_j(s) - \varepsilon_{g_j(x;s)}}{b_j^0(s) - \varepsilon_{g_j(x;s)}} & \text{if } b_j(s) + \varepsilon_{g_j(x;s)} \leq g_j(x;s) \leq b_j(s) + b_j^0(s) \\ 1 & \text{if } g_j(x;s) \geq b_j(s) + b_j^0(s) \end{cases} \quad (9.25)$$

where and for  $j = 1, 2, \dots, m$   $0 < \varepsilon_{g_j(x;s)}, \xi_{g_j(x;s)} < b_j^0$

where and for  $g_j(X;s) = \sigma_j(X;s)$  or  $\delta_j(X;s)$  or  $\tau_j(X;s)$ ,  $0 < \varepsilon_{g_j(X;s)} < b_j^0(s)$

then parametric NSO problem can be formulated as [107], i.e

**(P9.3)**

$$\text{Maximize } (\alpha + \gamma - \beta) \quad (9.26)$$

$$\text{such that } C(X;s) + (U_{C(X;s)}^T - L_{C(X;s)}^T) \cdot \alpha \leq U_{C(X;s)}^T; \quad (9.27)$$

$$C(X;s) + (U_{C(X;s)}^I - L_{C(X;s)}^I) \cdot \gamma \geq U_{C(X;s)}^I; \quad (9.28)$$

$$C(X;s) - (U_{C(X;s)}^F - L_{C(X;s)}^F) \cdot \beta \leq L_{C(X;s)}^F; \quad (9.29)$$

$$g_j(x;s) + (U_{g_j(x;s)}^T - L_{g_j(x;s)}^T) \cdot \alpha \leq U_{g_j(x;s)}^T; \quad (9.30)$$

$$g_j(x;s) + (U_{g_j(x;s)}^I - L_{g_j(x;s)}^I) \cdot \gamma \geq U_{g_j(x;s)}^I; \quad (9.31)$$

$$g_j(x;s) - (U_{g_j(x;s)}^F - L_{g_j(x;s)}^F) \cdot \beta \leq L_{g_j(x;s)}^F; \quad (9.32)$$

$$\alpha + \beta + \gamma \leq 3; \alpha \geq \beta; \alpha \geq \gamma; \alpha, \beta, \gamma \in [0, 1]; \quad (9.33)$$

$$x \geq 0, s \in [0, 1] \quad (9.34)$$

where  $g_j(X;s) = \sigma_j(X;s)$  or  $\delta_j(X;s)$  or  $\tau_j(X;s)$ ,  $0 < \varepsilon_{g_j(X;s)} < b_j^0(s)$

All these crisp nonlinear programming problems (P9.3) can be solved by appropriate mathematical algorithm.

### 9.3 Numerical Solution of Parametric Welded Beam Design Problem by NSO Technique

A welded beam (Ragsdell and Philips 1976, Fig.-9.1) has to be designed at minimum cost whose constraints are shear stress in weld ( $\tau$ ), bending stress in the beam ( $\sigma$ ), buckling

load on the bar ( $P$ ), and deflection of the beam ( $\delta$ ). The design variables are  $\begin{bmatrix} x_1 \\ x_2 \\ x_3 \\ x_4 \end{bmatrix} = \begin{bmatrix} h \\ l \\ t \\ b \end{bmatrix}$  where



$h$  is the weld size,  $l$  is the length of the weld,  $t$  is the depth of the welded beam,  $b$  is the width of the welded beam.

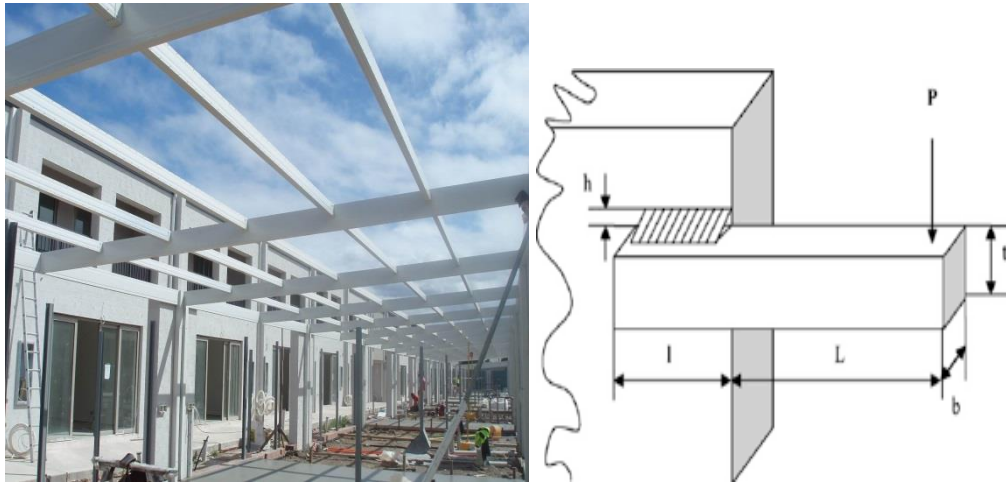

**Fig.-9.1 Design of the Welded Beam**(<http://www.spantec.com.au>, accessed on 20 June 2017)

The single-objective optimization problem can be stated as follows

**(P9.4)**

$$\text{Minimize } C(X) \equiv 1.10471x_1^2x_2 + 0.04811(14 + x_2)x_3x_4 \quad (9.35)$$

Such that

$$g_1(x) \equiv \tau(x) - \tau_{\max} \leq 0; \quad (9.36)$$

$$g_2(x) \equiv \sigma(x) - \sigma_{\max} \leq 0; \quad (9.37)$$

$$g_3(x) \equiv x_1 - x_4 \leq 0; \quad (9.38)$$

$$g_4(x) \equiv 0.10471x_1^2x_2 + 0.04811x_3x_4(14 + x_2) - 5 \leq 0; \quad (9.39)$$

$$g_5(x) \equiv 0.125 - x_1 \leq 0; \quad (9.40)$$

$$g_6(x) \equiv \delta(x) - \delta_{\max} \leq 0; \quad (9.41)$$

$$g_7(x) \equiv P - P_c(x) \leq 0; \quad (9.42)$$

$$0.1 \leq x_1, x_4, x_2, x_3 \leq 2.0$$

$$\text{where } \tau(x) = \sqrt{\tau_1^2 + 2\tau_1\tau_2 \frac{x_2}{2R} + \tau_2^2}; \quad (9.43)$$

$$\tau_1 = \frac{P}{\sqrt{2}x_1x_2}; \quad (9.44)$$

$$\tau_2 = \frac{MR}{J}; \quad (9.45)$$

$$M = P\left(L + \frac{x_2}{2}\right); \quad (9.46)$$

$$R = \sqrt{\frac{x_2^2}{4} + \left(\frac{x_1 + x_3}{2}\right)^2}; \quad (9.47)$$

$$J = \left\{ \frac{x_1 x_2}{\sqrt{2}} \left[ \frac{x_2^2}{12} + \left(\frac{x_1 + x_3}{2}\right)^2 \right] \right\}; \quad (9.48)$$

$$\sigma(x) = \frac{6PL}{x_4 x_3^2}; \quad (9.49)$$

$$\delta(x) = \frac{4PL^3}{Ex_4 x_3^2}; \quad (9.50)$$

$$P_c(x) = \frac{4.013\sqrt{EGx_3^6 x_4^6 / 36}}{L^2} \left( 1 - \frac{x_3}{2L} \sqrt{\frac{E}{4G}} \right); \quad (9.51)$$

$P$  = Force on beam ;  $L$  = Beam length beyond weld;  $x_1$  = Height of the welded beam;  $x_2$  = Length of the welded beam;  $x_3$  = Depth of the welded beam;  $x_4$  = Width of the welded beam;  $\tau(x)$  = Design shear stress;  $\sigma(x)$  = Design normal stress for beam material;  $M$  = Moment of  $P$  about the centre of gravity of the weld ,  $J$  = Polar moment of inertia of weld group;  $G$  = Shearing modulus of Beam Material;  $E$  = Young modulus;  $\tau_{\max}$  = Design Stress of the weld;  $\sigma_{\max}$  = Design normal stress for the beam material;  $\delta_{\max}$  = Maximum deflection;  $\tau_1$  = Primary stress on weld throat.  $\tau_2$  = Secondary torsional stress on weld. Input data are given in Table 10.1 and Table 10.2.

**Table 9.1 Input Data for Crisp Model (P9.4)**

Applied load $P$ ( $lb$ )	Beam length beyond weld $L$ ( $in$ )	Young Modulus $E$ ( $psi$ )	Value of $G$ ( $psi$ )
------------------------------	--	-----------------------------------	---------------------------

$600\tilde{0}$ $\equiv \left( \begin{array}{l} (5580, 6000, 6100; w_p) \\ (5575, 5590, 6110; \eta_p) \\ (5570, 5585, 6120; \lambda_p) \end{array} \right)$	14	$3 \times 10^6$	$12 \times 10^6$
---	----	-----------------	------------------

**Table 9.2 Input Data For Crisp Model (P9.4)**

Maximum allowable shear stress $\tau_{\max}$ ( <i>psi</i> )	Maximum allowable deflection $\delta_{\max}$ ( <i>in</i> )	Maximum allowable normal stress $\sigma_{\max}$ ( <i>psi</i> )
$1355\tilde{0} \equiv \left( \begin{array}{l} (13520, 13550, 13580; w_\tau) \\ (13510, 13540, 13570; \eta_\tau) \\ (13500, 13530, 13560; \lambda_\tau) \end{array} \right)$ Maximum allowable value	$0.2\tilde{5} \equiv \left( \begin{array}{l} (0.22, 0.25, 0.26; w_\delta) \\ (0.21, 0.24, 0.27; \eta_\delta) \\ (0.20, 0.23, 0.28; \lambda_\delta) \end{array} \right)$ Maximum allowable value	$300\tilde{0} \equiv \left( \begin{array}{l} (2980, 3000, 3030; w_\sigma) \\ (2975, 2990, 3020; \eta_\sigma) \\ (2970, 2985, 3010; \lambda_\sigma) \end{array} \right)$ Maximum allowable value
$1360\tilde{0} \equiv \left( \begin{array}{l} (13580, 13600, 13610; w_\tau^1) \\ (13575, 13590, 13615; \eta_\tau^1) \\ (13570, 13585, 136120; \lambda_\tau^1) \end{array} \right)$	$0.2\tilde{6} \equiv \left( \begin{array}{l} (0.23, 0.26, 0.27; w_\delta^1) \\ (0.22, 0.25, 0.28; \eta_\delta^1) \\ (0.21, 0.26, 0.29; \lambda_\delta^1) \end{array} \right)$	$310\tilde{0} \equiv \left( \begin{array}{l} (3070, 3100, 3130; w_\sigma^1) \\ (3060, 3090, 3120; \eta_\sigma^1) \\ (3050, 3080, 3110; \lambda_\sigma^1) \end{array} \right)$

where  $w_p, w_\sigma, w_\delta, w_\tau$  and  $w_p^1, w_\sigma^1, w_\delta^1, w_\tau^1$  are degree of truth membership or aspiration level and maximum degree of truth membership or aspiration level;  $\eta_p, \eta_\sigma, \eta_\delta, \eta_\tau$ ;  $\eta_p^1, \eta_\sigma^1, \eta_\delta^1, \eta_\tau^1$  are degree of indeterminacy and maximum degree of indeterminacy and  $\lambda_p, \lambda_\sigma, \lambda_\delta, \lambda_\tau$  and  $\lambda_p^1, \lambda_\sigma^1, \lambda_\delta^1, \lambda_\tau^1$  are degree of falsity and maximum degree of falsity or desperation level of applied load, normal stress, deflection and allowable shear stress respectively.

Now parameterized value of interval valued function can be calculated as

$$\hat{P} = \left( \left( 5575 + \frac{70}{w_a} + \frac{2.5}{\eta_a} + \frac{2.5}{\tau_a} \right)^{1-s} \left( 6110 - \frac{16.67}{w_a} + \frac{86.67}{\eta_a} + \frac{89.17}{\tau_a} \right)^s \right); \quad (9.52)$$

$$\hat{\tau}^{\max} = \left( \left( 13510 + \frac{5}{w_a} + \frac{5}{\eta_a} + \frac{5}{\tau_a} \right)^{1-s} \left( 13570 - \frac{1.67}{w_a} + \frac{5}{\eta_a} + \frac{5}{\tau_a} \right)^s \right); \quad (9.53)$$

Allowable value of  $\hat{\tau}^{\max}$

$$\hat{\tau}_1^{\max} = \left( \left( 13575 + \frac{3.33}{w_a} + \frac{2.5}{\eta_a} + \frac{2.5}{\tau_a} \right)^{1-s} \left( 13615 - \frac{1.67}{w_a} + \frac{4.17}{\eta_a} + \frac{5.83}{\tau_a} \right)^s \right); \quad (9.54)$$

$$\hat{\delta}^{\max} = \left( \left( 0.21 + \frac{0.005}{w_a} + \frac{0.005}{\eta_a} + \frac{0.005}{\tau_a} \right)^{1-s} \left( 0.27 - \frac{0.001}{w_a} + \frac{0.005}{\eta_a} + \frac{0.008}{\tau_a} \right)^s \right); \quad (9.55)$$

Allowable value of  $\hat{\delta}^{\max}$

$$\hat{\delta}_1^{\max} = \left( \left( 0.22 + \frac{0.005}{w_a} + \frac{0.005}{\eta_a} + \frac{0.005}{\tau_a} \right)^{1-s} \left( 0.28 - \frac{0.001}{w_a} + \frac{0.005}{\eta_a} + \frac{0.008}{\tau_a} \right)^s \right); \quad (9.56)$$

$$\hat{\sigma}^{\max} = \left( \left( 2975 + \frac{3.33}{w_a} + \frac{2.5}{\eta_a} + \frac{2.5}{\tau_a} \right)^{1-s} \left( 3020 - \frac{1.67}{w_a} + \frac{5}{\eta_a} + \frac{7.5}{\tau_a} \right)^s \right); \quad (9.57)$$

Allowable value of  $\hat{\sigma}^{\max}$

$$\hat{\sigma}_1^{\max} = \left( \left( 3060 + \frac{5}{w_a} + \frac{5}{\eta_a} + \frac{5}{\tau_a} \right)^{1-s} \left( 3120 - \frac{1.67}{w_a} + \frac{5}{\eta_a} + \frac{8.83}{\tau_a} \right)^s \right); \quad (9.58)$$

**Table 9.3 The Upper and Lower Value of Objective(P9.4) for Different Values of  $w$  Pessimistic Value of  $s$**

The pessimistic value of $s=0.2$			
Aspiration level ,uncertainty level and desperation level $w_p = w_\sigma = w_\delta = w_\tau$ $= w_p = w_\sigma^1 = w_\delta^1 = w_\tau^1 = w$  $\eta_p = \eta_\sigma = \eta_\delta = \eta_\tau$ $= \eta_\sigma^1 = \eta_\delta^1 = \eta_\tau^1 = \eta$  $\lambda_p = \lambda_\sigma = \lambda_\delta = \lambda_\tau$ $= \lambda_\sigma^1 = \lambda_\delta^1 = \lambda_\tau^1 = \lambda$	$w = \eta = \lambda = 0.3$	$w = \eta = \lambda = 0.5$	$w = \eta = \lambda = 0.7$

Upper and lower value of objective	$L_{c(x)}^T = 0.1419847,$ $U_{c(x)}^T = 0.1425069$	$L_{c(x)}^T = 0.1387723,$ $U_{c(x)}^T = 0.1393634$	$L_{c(x)}^T = 0.1374016,$ $U_{c(x)}^T = 0.1380209$
------------------------------------	---	---	---

**Table 9.4 The Upper and Lower Value of Objective (P9.4) for Different Values of  $w$ , Moderate Value of  $s$**

The pessimistic value of $s=0.5$			
Aspiration level, uncertainty level and desperation level $w_p = w_\sigma = w_\delta = w_\tau$ $= w_p = w_\sigma^1 = w_\delta^1 = w_\tau^1 = w$  $\eta_p = \eta_\sigma = \eta_\delta = \eta_\tau$ $= \eta_\sigma^1 = \eta_\delta^1 = \eta_\tau^1 = \eta$  $\lambda_p = \lambda_\sigma = \lambda_\delta = \lambda_\tau$ $= \lambda_\sigma^1 = \lambda_\delta^1 = \lambda_\tau^1 = \lambda$	$w = \eta = \lambda = 0.3$	$w = \eta = \lambda = 0.5$	$w = \eta = \lambda = 0.7$
Upper and lower value of objective	$L_{c(x)}^T = 0.1485833,$ $U_{c(x)}^T = 0.1491453$	$L_{c(x)}^T = 0.1444032,$ $U_{c(x)}^T = 0.1450005$	$L_{c(x)}^T = 0.1426218,$ $U_{c(x)}^T = 0.1432331$

**Table 9.5 The Upper and Lower Value of Objective (P9.4) for Different Values of  $w$  Optimistic Value of  $s$**

The pessimistic value of $s=0.8$			
Aspiration level, uncertainty level and desperation level $w_p = w_\sigma = w_\delta = w_\tau$ $= w_p = w_\sigma^1 = w_\delta^1 = w_\tau^1 = w$  $\eta_p = \eta_\sigma = \eta_\delta = \eta_\tau$ $= \eta_\sigma^1 = \eta_\delta^1 = \eta_\tau^1 = \eta$	$w = \eta = \lambda = 0.3$	$w = \eta = \lambda = 0.5$	$w = \eta = \lambda = 0.7$

$\lambda_p = \lambda_\sigma = \lambda_\delta = \lambda_\tau$ $= \lambda_\sigma^1 = \lambda_\delta^1 = \lambda_\tau^1 = \lambda$			
Upper and lower value of objective	$L_{C(x)}^T = 0.1555725$ $U_{C(x)}^T = 0.1561771$	$L_{C(x)}^T = 0.1503266$ $U_{C(x)}^T = 0.1509290$	$L_{C(x)}^T = 0.1480966$ $U_{C(x)}^T = 0.1486975$

Now using truth, indeterminacy and falsity membership function as mentioned in section 10.4 neutrosophic optimization problem can be formulated as similar as (P9.4) and solving this optimal for different values of  $s, w, \eta, \lambda$ , design variables and objective functions can be obtained as follows.

**Table 9.6 The Optimum Values of Design Variables(P9.4) for Different Values of  $w, \eta, \lambda$  and  $s = 0.2$**

Value of $\varepsilon_i, \xi_i$ .Aspiration level ,uncertainty level and desperation level	$w = \eta = \lambda = 0.3$ $\varepsilon_i =$ $(U_i^T - L_i^T) \times 0.1$  $\xi_i =$ $(U_i^T - L_i^T) \times 0.1$	$w = \eta = \lambda = 0.5$ $\varepsilon_i =$ $(U_i^T - L_i^T) \times 0.1$  $\xi_i =$ $(U_i^T - L_i^T) \times 0.1$	$w = \eta = \lambda = 0.7$ $\varepsilon_i =$ $(U_i^T - L_i^T) \times 0.1$  $\xi_i =$ $(U_i^T - L_i^T) \times 0.1$
$w_p = w_\sigma = w_\delta = w_\tau$ $= w_p = w_\sigma^1 = w_\delta^1 = w_\tau^1 = w$			
$\eta_p = \eta_\sigma = \eta_\delta = \eta_\tau$ $= \eta_\sigma^1 = \eta_\delta^1 = \eta_\tau^1 = \eta$			
$\lambda_p = \lambda_\sigma = \lambda_\delta = \lambda_\tau$ $= \lambda_\sigma^1 = \lambda_\delta^1 = \lambda_\tau^1 = \lambda$			
$x_1(in)$	0.3415895	0.3389869	0.3378618
$x_2(in)$	0.9535080	0.9463785	0.9433100
$x_3(in)$	2	2	2
$x_4(in)$	1.089426	1.080890	1.077210
$C(X) (\$)$	0.1420369	0.1388314	0.1374635

Where  $U_i$  and  $L_i$  are upper and lower bound of respective objective and The Optimum constraints.

**Table 9.7 The Optimum Values of Design Variables(P9.4) for Different Values of  $w, \eta, \lambda$  and  $s = 0.5$**

Value of $\varepsilon_i, \xi_i$ , Aspiration level uncertainty level and desperation level  $w_p = w_\sigma = w_\delta = w_\tau$ $= w_p^1 = w_\sigma^1 = w_\delta^1 = w_\tau^1 = w$  $\eta_p = \eta_\sigma = \eta_\delta = \eta_\tau$ $= \eta_\sigma^1 = \eta_\delta^1 = \eta_\tau^1 = \eta$  $\lambda_p = \lambda_\sigma = \lambda_\delta = \lambda_\tau$ $= \lambda_\sigma^1 = \lambda_\delta^1 = \lambda_\tau^1 = \lambda$	$w = \eta = \lambda = 0.3$ $\varepsilon_i =$ $(U_i^T - L_i^T) \times 0.1$  $\xi_i =$ $(U_i^T - L_i^T) \times 0.1$	$w = \eta = \lambda = 0.5$ $\varepsilon_i =$ $(U_i^T - L_i^T) \times 0.1$  $\xi_i =$ $(U_i^T - L_i^T) \times 0.1$	$w = \eta = \lambda = 0.7$ $\varepsilon_i =$ $(U_i^T - L_i^T) \times 0.1$  $\xi_i =$ $(U_i^T - L_i^T) \times 0.1$
$x_1(in)$	0.3422657	0.3396719	0.3385506
$x_2(in)$	0.9552806	0.9481638	0.9451009
$x_3(in)$	2	2	2
$x_4(in)$	1.091979	1.083465	1.079794
$C(X)$ (\$)	0.1486395	0.1444629	0.1426829

Where  $U_i$  and  $L_i$  are upper and lower bound of respective objective and constraints.

**Table 9.8 The Optimum Values of Design Variables(P9.4) for Different Values of  $w, \eta, \lambda$  and  $s = 0.8$**

Value of $\varepsilon_i, \xi_i$ , Aspiration level ,uncertainty level and desperation level  $w_p = w_\sigma = w_\delta = w_\tau$ $= w_p^1 = w_\sigma^1 = w_\delta^1 = w_\tau^1 = w$  $\eta_p = \eta_\sigma = \eta_\delta = \eta_\tau$ $= \eta_\sigma^1 = \eta_\delta^1 = \eta_\tau^1 = \eta$	$w = \eta = \lambda = 0.3$ $\varepsilon_i =$ $(U_i^T - L_i^T) \times 0.1$  $\xi_i =$ $(U_i^T - L_i^T) \times 0.1$	$w = \eta = \lambda = 0.5$ $\varepsilon_i =$ $(U_i^T - L_i^T) \times 0.1$  $\xi_i =$ $(U_i^T - L_i^T) \times 0.1$	$w = \eta = \lambda = 0.7$ $\varepsilon_i =$ $(U_i^T - L_i^T) \times 0.1$  $\xi_i =$ $(U_i^T - L_i^T) \times 0.1$
$x_1(in)$	0.3422657	0.3396719	0.3385506
$x_2(in)$	0.9552806	0.9481638	0.9451009
$x_3(in)$	2	2	2
$x_4(in)$	1.091979	1.083465	1.079794
$C(X)$ (\$)	0.1486395	0.1444629	0.1426829

$\lambda_p = \lambda_\sigma = \lambda_\delta = \lambda_\tau$ $= \lambda_\sigma^1 = \lambda_\delta^1 = \lambda_\tau^1 = \lambda$			
$x_1(in)$	0.3429429	0.3403578	0.3392404
$x_2(in)$	0.9570581	0.9499542	0.9468969
$x_3(in)$	2	2	2
$x_4(in)$	1.094538	1.086046	1.082384
$C(X) (\$)$	0.1556330	0.1503868	0.1503868

Where  $U_i$  and  $L_i$  are upper and lower bound of respective objective and constraints

From the above results it is clear that whenever we chose  $w = \eta = \lambda = 0.7$  and  $s = 0.2$ , the of cost welding is minimum most. Also it has been observed that cost of welding is decreased by higher value of aspiration level, uncertainty level and desperation level for a particular value of parameter 's'.

## 9.4 Conclusion

In this chapter we have proposed a method to solve WBD in fully neutrosophic environment. Here GNN has been considered for deflection and stress parameter. The said model is solved by Single Objective Parametric Neutrosophic Optimization (SOPNSO) technique and result is calculated for different parameter. The main advantage of the described method is that it allows us to overcome the actual limitations in a problem where impreciseness of supplied data is involved during the specification of the objectives. This approximation method can be applied to optimize different models in various fields of engineering and sciences.



# CHAPTER 10

---

## Optimization of Thickness of Jointed Plain Concrete Pavement Using Neutrosophic Optimization Technique

---

Highway construction agencies throughout the globe chasing accelerating demands on durable undowelled Jointed Plain Concrete Pavement (JPCP) due to scanty of rehabilitation of the same . Since decades, different design methods had been developed by various organizations which suit their locale and fix the depth criteria of the JPCP along with other parameters by satisfying the standard code of practice but none of them tries to optimize the design thickness of the same (Hadi and Arfiadi, [53]). However a few approaches designed such thickness of cited pavement by considering traffic overloading condition, its fatigue life and the fluctuation of ambient temperature effect individually (Maser et al., [74];Ramsamooj [91];Levenberg, [68]). But during service life of such pavement, the traffic loads and adverse environmental effect would deteriorate its joints and ultimately its foundation. Therefore optimization of such rigid pavement is become essential considering multiple decision making criteria as stated above to make it more durable.

Several design methods e.g. **AASHTO**, **PCA**, Crop of Engineers of the US army iteration method etc. are available to determine the thickness of JPCP. However all such methods follow numerous monographs, tables and charts to do the same and abiding by certain loop of algorithm in the cited iteration process to find an effective thickness of such pavement. But most of the time, designers stop the cited procedure even after two or three trials which yields safe but unnecessarily less economical thick rigid pavement (Hadi and Arfiadi, [53]). However lots of efforts had been made to get rid of from such problem but optimization on the same subject has rarely found. Moreover, finite element method (Davids, [40]) and genetic Algorithm (Hadi and Arfiadi, [53]) type of crisp optimization method had been applied on the cited subject, where the values of the input parameters were obtained from experimental data in laboratory scale. While the above cited standards has already ranged the magnitude of those parameters in between maximum to the minimum value. Therefore, designer get confused to select those input parameters from such ranges which yield three key governing factors i.e. degree of acceptance, rejection and hesitancy that attributes the

necessity of neutrosophic fuzzy set (Das et al., [39]; Sarkar et al., [107]). Meanwhile, Wang et.al [120] presented such set as Single Valued Neutrosophic Set (SVNS) as it comprised of generalized classic set, Fuzzy set, interval valued fuzzy set, Intuitionistic Fuzzy Set and para consistent set respectively.

As application of SVNS optimization method is rare in rigid pavement design; hence it is used to minimize the thickness of the pavement by considering cumulative fatigue life and deflection as constraints respectively. However the factors governing of former constraints are axel loads, pavement thickness, modulus of elasticity of cement concrete, subgrade modulus, poisson's ratio, load contact area, annual rate of growth of commercial traffic, number of axel per day, radius of relative stiffness and design period respectively. While, the later constraint includes radius of load contact area, subgrade modulus, radius of relative stiffness and single as well as tandem axel loads respectively. Besides that, in this effort flexibility has been given in number of axel per day in fatigue life constraint only; hence cumulative vehicle per day (CVPD) becomes imprecise in nature so that it can be considered as neutrosophic set to from truth, indeterminacy and falsity membership functions. Ultimately neutrosophic optimization technique can be applied on the basis of cited membership functions and outcome of such Nonlinear Optimum Pavement Design (NLOPD) tries to provide the minimum thickness for varying subgrade modulus of soil.

### 10.1 Formulation for Optimum JPCP Design

The first step of formulation of JPCP is to formulate the pavement optimization problem by defining objective function (minimum thickness) and the constraints (fatigue life consumed, deflection and corner stress due to single and tandem axle) that control the solution.

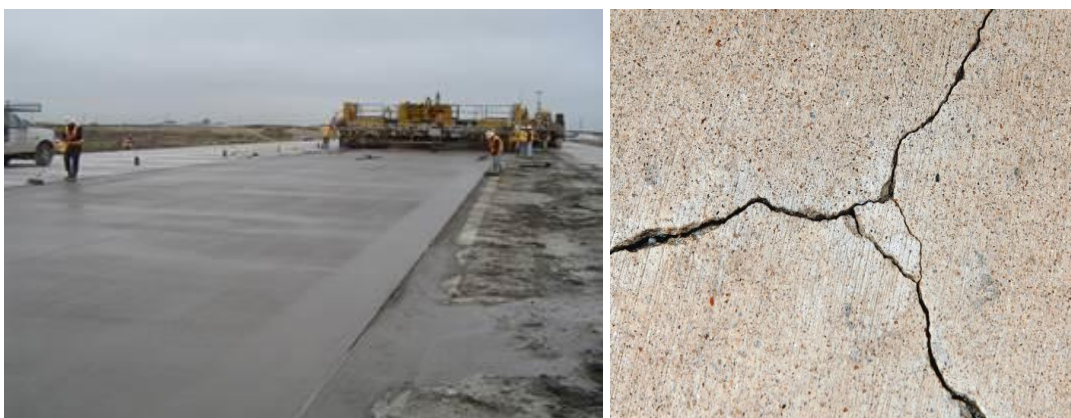

**Fig.-10.1 Construction and Fatigue Failure of JPCP(<http://www.escsi.org>,**

### 10.1.1 Design input parameters

The input parameters that influence the design are Poisson ratio ( $\nu$ ), Load due to single axle ( $P_1$ ), Load due to tandem axle ( $P_2$ ), Modulus of elasticity of concrete ( $E$ ), Modulus of subgrade reaction ( $k$ ), Radius of load contact areas assumed circular ( $a$ ), Initial number of axles per day in the year ( $A$ ), Design period in year ( $n$ ), Annual rate of growth of commercial traffic ( $r$ ), Limiting value of deflection due to single axle ( $d_1$ ), Limiting value of deflection due to tandem axle ( $d_2$ ), Flexural strength of concrete ( $S_f$ ),

### 10.1.2 Design method

For determining optimum thickness of JPCP, a crisp mathematical model has been formulated. Here Thickness of Slab (TS) has been minimized subjected to a specified set of constraints (P11.1). Here the optimum design is

(P10.1)

$$\text{Minimize } TS(h) \equiv h \quad (10.1)$$

subject to

$$F_1(l, h, k, A_1, A_2) \equiv \left[ 365 \times \left\{ (1+r)^n - 1 \right\} \right]^2 \left[ (SR_1(h) - 0.4325)(SR_2(h) - 0.4325) \right]^{3.268} A_1 A_2 \leq (0.5)^2 (4.2577)^{6.536} r^2 \quad (10.2)$$

$$F_2(l, h, k, A_1, A_2) \equiv 2 \text{Log} \left[ \frac{365 \times \left\{ (1+r)^2 - 1 \right\} \times 0.25}{r \times 0.25} \right] + \left( \frac{SR_1(h) + SR_2(h)}{0.0828} \right) - 23.47 \leq \text{Log}(A_1 A_2) \quad (10.3)$$

$$D_{SAL}(k, l) \equiv \frac{0.431P_1}{kl^2} \left[ 1 - 0.82 \left( \frac{a}{l} \right) \right] \leq d_1 \quad (10.4)$$

$$D_{TAL}(k, l) \equiv \frac{0.431P_2}{kl^2} \left[ 1 - 0.82 \left( \frac{a}{l} \right) \right] \leq d_2 \quad (10.5)$$

$$S_{SAL}^C(h) \equiv \frac{3P_1}{h^2} \left[ 1 - \left( \frac{a\sqrt{2}}{l} \right)^{1.2} \right] \leq S_f \quad (10.6)$$

$$S_{TAL}^C(h) \equiv \frac{3P_2}{h^2} \left[ 1 - \left( \frac{a\sqrt{2}}{l} \right)^{1.2} \right] \leq S_f \quad (10.7)$$

$$A_{IA}(A_1, A_2) \equiv A_1 + A_2 \leq A \quad (10.8)$$

$$l, h, A_1, A_2 > 0; l_k \leq k \leq u_k \quad (10.9)$$

where

$$SR_i(h) = \frac{3(1+\nu)P_i}{\pi(3+\nu)h^2} \left[ \ln \left( \frac{Eh^3}{100ka^4} \right) + 1.84 - \frac{4\nu}{3} + \frac{1-\nu}{2} + \frac{1.18(1+2\nu)a}{l} \right] \text{ for } i=1,2 \quad (10.10)$$

The Non-linear Programming Problems (NLPPs) under crisp scenario, the aim is to maximize or minimize a objective function under constraints. But in many practical situations, the decision maker may not be in a position to specify the objective and/or constraint functions precisely bur rather can specify in imprecise sense. In such situation, it is desirable to use some NNLP type of modelling for providing more flexibility to the decision maker. Since the impreciseness may appear in a NLP in many ways (e.g. the inequalities may be imprecise, the goals may be imprecise or the problem parameters like initial number of axle per day in year and deflection may be flexible in nature)so the definition of NNLP is not unique .Here initial number of axle per day in year and deflection have been considered imprecise so that the limiting value of fatigue analysis constraints, sum of initial axle per day in year, deflection due to single axle load and tandem axle load are assumed as  $w; q; A; d_1; d_2$  with maximum allowable tolerance  $p_w; p_q; p_A, p_{d_1}, p_{d_2}$  respectively .Thus above problem is formulated as a nonlinear programming problem with precise and imprecise resources as

**(P10.2)**

$$\text{Minimize } TS(h) \equiv h \quad (10.11)$$

such that

$$F_1(l, h, k, A_1, A_2) \lesssim w \text{ (with maximum allowable tolerance } p_w \text{)} \quad (10.12)$$

$$F_2(l, h, k, A_1, A_2) \lesssim q \text{ (with maximum allowable tolerance } p_q \text{)}; \quad (10.13)$$

$$D_{SAL}(l, k) \lesssim d_1 \text{ (with maximum allowable tolerance } p_{d_1} \text{)}; \quad (10.14)$$

$$D_{TAL}(l, k) \lesssim d_2 \left( \text{with maximum allowable tolerance } p_{d_2} \right); \quad (10.15)$$

$$S_{SAL}^C(h) \leq S_f; \quad (10.16)$$

$$S_{TAL}^C(h) \leq S_f \quad (10.17)$$

$$A_{LA}(A_1, A_2) \lesssim A \left( \text{with maximum allowable tolerance } p_A \right) \quad (10.18)$$

$$l, h, t, A_1, A_2 > 0, \quad l_k \leq k \leq u_k \quad (10.19)$$

Where  $l_k$  and  $u_k$  are the lower and upper limit of  $k$  respectively

$$F_1(l, h, k, A_1, A_2) \equiv \left[ 365 \times \left\{ (1+r)^2 - 1 \right\} \times 0.25 \right]^2 \left[ (SR_1 - 0.4325)(SR_2 - 0.4325) \right]^{3.268} \quad (10.20)$$

$$w = \frac{(0.5)^2 (4.2577)^{6.536} r^2}{A_1 A_2} \quad (10.21)$$

$$F_2(l, h, k, A_1, A_2) \equiv 2 \text{Log} \left[ \frac{365 \times \left\{ (1+r)^2 - 1 \right\} \times 0.25}{r \times 0.5} \right] + \left( \frac{SR_1 + SR_2}{0.0828} \right) - 23.47; \quad (10.22)$$

$$q = \text{Log}(A_1 A_2) \quad (10.23)$$

$$D_{SAL}(k, l) \equiv \frac{0.431P_1}{kl^2} \left[ 1 - 0.82 \left( \frac{a}{l} \right) \right] \quad (10.24)$$

$$D_{TAL}(k, l) \equiv \frac{0.431P_2}{kl^2} \left[ 1 - 0.82 \left( \frac{a}{l} \right) \right] \quad (10.25)$$

$$A_{LA}(A_1, A_2) = A_1 + A_2 \quad (10.26)$$

$$SR_i(h) = \frac{3(1+\nu)P_i}{\pi(3+\nu)h^2} \left[ \ln \left( \frac{Eh^3}{100ka^4} \right) + 1.84 - \frac{4\nu}{3} + \frac{1-\nu}{2} + \frac{1.18(1+2\nu)a}{l} \right] S_f$$

$$\text{for } i=1,2 \quad (10.27)$$

To solve above nonlinear programming problem (P10.2) we have used Neutrosophic Optimization Technique

## 10.2 Neutrosophic Optimization

In conventional optimization problems, it is assumed that the decision maker is sure about the precise values of data involved in the model. But in real world applications all the parameters and goals (objective goals ,constraint goals etc.) of the optimization problems may not be known precisely due to uncontrollable factors. Such type of imprecise parameters and goals are represented by fuzzy set theory (Zadeh [133])

Actually, a decision maker may assume that an object belongs to a set to a certain degree, but it is possible that he is not sure about it. In other words, there may be uncertainty about the membership degree. The main premise is that the parameters' demands across the problem are uncertain. So, they are known to fall within a prescribed uncertainty set with some attributed degree. In fuzzy set theory, there is no means to incorporate this hesitation in the membership degree. To incorporate the uncertainty in the membership degree, intuitionistic fuzzy sets (IFSs) proposed by Atanassov [1] is an extension of fuzzy set theory. In intuitionistic fuzzy set theory along with degree of membership a degree of non-membership is usually considered to express ill-know quantity. This degree of membership and non-membership functions are so defined as they are independent to each other and sum of them is less or equal to one. So IFS is playing an important role in decision making under uncertainty and has gained popularity in recent years. However an application of the IFSs to optimization problems introduced by Angelov [4] His technique is based on maximizing the degree of membership, minimizing the degree of non-membership and the crisp model is formulated using the IF aggregation operator.

Now the fact is that in IFS indeterminate information is partially lost ,as hesitant information is taken in consideration by default. So indeterminate information should be considered in decision making process. Smarandache [94] defined NS that could handle indeterminate and inconsistent information. In neutrosophic sets indeterminacy is quantified explicitly with truth membership, indeterminacy membership and falsity membership function which are independent .Wang et.al [120] define SVNS which represents imprecise, incomplete, indeterminate, inconsistent information. Thus taking the universe as a real line we can develop the concept of single valued NS as special case of NS. These set is able to express

ill-known quantity with uncertain numerical value in decision making problem. It help more adequately to represent situations where decision makers abstain from expressing their assessments. In this way NS provide a richer tool to grasp impression and ambiguity than the conventional fuzzy as well as IFS. These characteristics of neutrosophic set led to the extension of optimization methods in Neutrosophic Environment (NSE).

Besides It has been seen that the current research on fuzzy mathematical programming is limited to the range of linear programming introduced by Ziemmermann[136] . He showed that the solutions of Fuzzy Linear Programming Problems (FLPPs) are always efficient. The most common approach for solving fuzzy linear programming problem is to change it into corresponding crisp linear programming problem. But practically there exist many fuzzy and intuitionistic fuzzy nonlinear structural , pavement design problems in the field of civil engineering. These problems cannot be modelled as a linear form and solved by traditional techniques due to presence of imprecise information.

So, the research on modelling and optimization for nonlinear programming under fuzzy intuitionistic fuzzy and neutrosophic environment are not only necessary in the fuzzy optimization theory but also has great and wide value in application to structural engineering problems of conflicting and imprecise nature. So following nonlinear neutrosophic optimization technique ( Sarkar et.al.[100]) the proposed nonlinear JPCP (P10.1) for the first time ever being solved with LINGO 11.0 in neutrosophic environment in this chapter and literature. LINGO 11.0 is a comprehensive tool designed to make building and solving mathematical optimization models easier and more efficient. LINGO provides a completely integrated package that includes a powerful language for expressing optimization models, a full-featured environment for building and editing problems, and a set of fast built-in solvers capable of efficiently solving most classes of optimization models. However the outcome of this investigation has been furnished in the following flowchart by incorporating all the essential parameters associated with the pavement design. In this regard it can be cited that fuzzy, IF and neutrosophic NLP are rarely involved in literature and Das et.al [25] developed neutrosophic NLP with numerical example and application of real life problem recently.

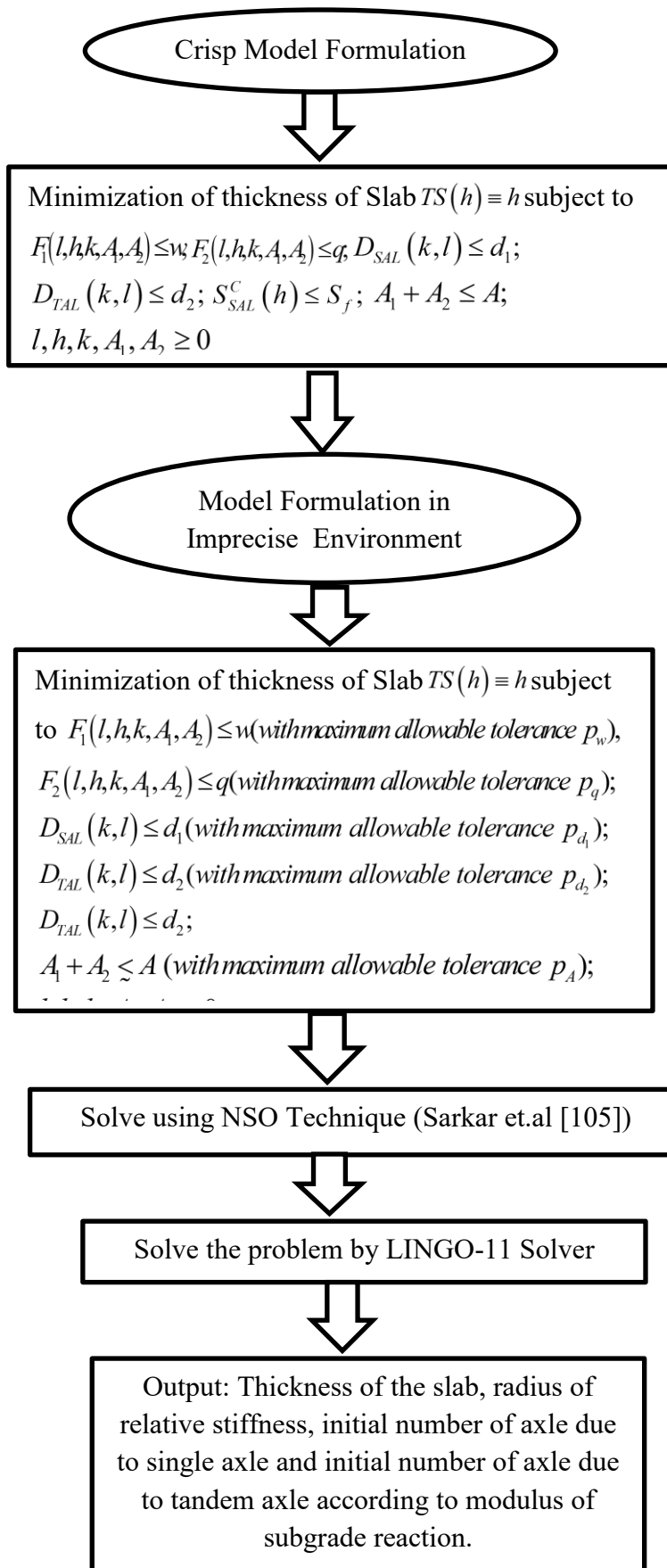

**Fig.-10.2 Flow Chart for Work Plan of The JPCP Design Study**



### 10.3 Numerical Illustration of Optimum JPCP Design based on IRC:58-2002

For designing the thickness of rigid pavement, Indian Roads Congress (IRC: 58-2002) [17] recommends a guideline for incorporating the input data e.g. Poisson ratio ( $\nu$ ) as 0.15, legal single axle load ( $P_1$ ) and legal tandem axle load ( $P_2$ ) as 10200 kg and 19000 kg respectively, Modulus of elasticity of concrete ( $E$ ) as  $3 \times 10^5$  kg/cm<sup>2</sup>, Modulus of subgrade reaction ( $k$ ) ranging from 6 to 22 kg/cm<sup>3</sup>, design period as 20 years, Annual rate of growth of commercial traffic ( $r$ ) as 7.5%, Limiting value of deflection due to single axle ( $d_1$ ) as well as to tandem axle ( $d_2$ ) as 0.1 with maximum allowable tolerance 0.025, Flexural Strength of Concrete ( $S_f$ ) as 45 kg/cm<sup>2</sup> and Radius of load contact areas ( $a$ ) assumed as circular. By following such guidelines, a sample calculation was made for National Highway (NH) considering the trial thickness as 32 cm for subgrade modulus of  $8 \text{ kg/cm}^3$  considering peak vehicular load passing through it. Flexibility to the axles per day in the year with the range of its value greater than equal to 3000 having 250 tolerance in the unit of Commercial Vehicle Per Day (CVPD) was considered as per standard guidelines (IRC-58-2002)[14]. Further 25 % of the total CVPD in the direction of predominant traffic was also taken into consideration but that trial became unsafe. However by considering thickness of the said pavement as 33 cm become safe.

Now following Neutrosophic Optimization Method (Sarkar et.al [105]) imprecise model (P10.2) can be reduced to following crisp linear programming problem as

**(P10.3)**

$$\text{Maximize } (\theta + \kappa - \eta) \quad (10.28)$$

such that

$$TS(h) + \theta \frac{(32.48638 - 31.97258)}{\psi} \leq 32.48638; \quad (10.29)$$

$$TS(h) + \kappa.5138 \leq 32.48638; \quad (10.20)$$

$$TS(h) + \frac{\eta}{\tau_h} \leq \frac{32.48638 + 31.97258 + 0.05138}{2}; \quad (10.21)$$

$$A_{IA}(A_1, A_2) + \theta \frac{(250)}{\psi} \leq 3250; \quad (10.22)$$

$$A_{IA}(A_1, A_2) + \frac{\eta}{\tau_{D_{TAL}(l,k)}} \leq \frac{6250 + 25}{2}; \quad (10.23)$$

$$A_{IA}(A_1, A_2) + \kappa 25 \leq 3250; \quad (10.24)$$

$$D_{SAL}(l, k) + \theta \frac{(0.125 - 0.1)}{\psi} \leq 0.125; \quad (10.25)$$

$$D_{SAL}(l, k) + \frac{\eta}{\tau_{D_{SAL}(l,k)}} \leq \frac{0.125 + 0.1 + .0025}{2}; \quad (10.26)$$

$$D_{SAL}(l, k) + \kappa .0025 \leq 0.125; \quad (10.27)$$

$$D_{TAL}(l, k) + \theta \frac{(0.125 - 0.1)}{\psi} \leq 0.125; \quad (10.28)$$

$$D_{TAL}(l, k) + \frac{\eta}{\tau_{D_{TAL}(l,k)}} \leq \frac{0.125 + 0.1 + .0025}{2}; \quad (10.29)$$

$$D_{TAL}(l, k) + \kappa .0025 \leq 0.125; \quad (10.30)$$

$$\theta + \kappa + \eta \leq 3; \theta \geq \kappa; \theta \geq \eta; \quad (10.31)$$

$$\theta, \kappa, \eta \in [0, 1]; l, h, A_1, A_2 > 0, \quad l_k \leq k \leq u_k$$

(10.32)

Where

$$A_{IA}(A_1, A_2) = A_1 + A_2; \quad (10.33)$$

$$\theta = -\ln(1 - \alpha); \quad (10.34)$$

$$\psi = 4; \quad (10.35)$$

$$\tau_h = \frac{6}{(32.48638 - 31.97258 - 0.05138)}; \quad (10.36)$$

$$\tau_{D_{SAL}(l)} = \frac{6}{(0.025 - .0025)}; \quad (10.37)$$

$$\tau_{D_{TAL}(l,k)} = \frac{6}{(.025 - .0025)}; \quad (10.38)$$

$$\tau_{A_{IA}(A_1, A_2)} = \frac{6}{(250 - 25)}; \quad (10.39)$$

$$\kappa = \ln \gamma; \quad (10.40)$$

$$\eta = -\tanh^{-1}(2\beta - 1). \quad (10.41)$$

$$\alpha + \beta + \gamma \leq 3; \quad (10.42)$$

$$\alpha, \beta, \gamma \in [0, 1] \quad (10.43)$$

Here impreciseness on flexible constraints is taken as single valued neutrosophic set with nonlinear truth, indeterminacy and falsity membership functions. It is noted that if proper nonlinear membership functions are chosen based on past experience, we may get better results. For example we have chosen exponential and hyperbolic membership functions. The result have been calculated for  $k = 6 - 22$ . For example the numerical expression has been shown for  $k = 8$ . The optimum value of Thickness of the slab, radius of relative stiffness, optimum value of initial number axle per day in year due to single axle load and due to tandem axle load according to modulus of subgrade reaction have been shown in the Table.10.1.

**Table 10.1 Optimum Thickness of JPCP using NSO Technique**

Modulus of subgrade reaction (k kg/cm <sup>3</sup> )	Thickness of slab (h* cm)	Radius of relative stiffness. (l* cm)	Initial number of axle due to single axle load (A <sub>1</sub> *)	Initial number of axle due to tandem axle load (A <sub>2</sub> *)
6	32.84625	102.7743	.0025	2999.997
7	32.51866	95.10986	169.0116	2884.639
8	32.25517	95.10986	1568.750	1568.750
9	31.95554	83.10438	.00258	2999.997
10	31.69637	77.85755	.003095	3053.647
11	31.39012	74.32656	.04876	3053.602
12	31.15804	73.85598	1568.750	1568.750
13	30.89417	67.26979	1568.750	1568.750
14	30.63287	64.51202	1568.750	1568.750

15	30.37357	62.03011	.0258	2999.997
16	30.11578	59.78019	1568.750	1568.750
17	29.85905	57.72759	1568.750	1568.750
18	29.60300	55.84443	0.258	2999.997
19	29.34726	54.10806	1568.750	1568.750
20	29.09102	53.18488	856.2631	2143.737
21	28.83046	51.63307	.0258	2999.997
22	28.57874	49.60825	.0025	2999.997

In Table.10.1 the optimum thickness of slab ,radius of relative stiffness, initial number of axle per day in year due to single axle load and tandem axle load are calculated according to modulus of subgrade reaction. However as expected ,the thickness (h) ,and radius of relative stiffness (l)of JPCP has tent to decrease with the increment of modulus of subgrade reaction (k)and at the value of k=8 the optimum thickness is 32.25517 which supports a safe PCA experimental value (IRC:58-2002).The optimum thickness obtained by neutrosophic optimization technique has shown 2.26% lesser value compared to the calculated value as shown in IRC:58-2002. There is no significant change of optimum thickness with change of modulus of subgrade reaction and as a whole the model formulation become cost effective. In the present study the optimum radius of relative stiffness has been calculated as 87.98206 for k=8 which is 14.99%less value supported by IRC:58-2002 .

#### 10.4 Conclusion

This work investigates how NSO technique can be utilized to solve a JPCP problem. The concept of NSO technique allows one to define a degree of truth membership, which is not a complement of degree of falsity; rather, they are independent with degree of indeterminacy. In this problem actually we investigate the effect of nonlinear truth, indeterminacy and falsity membership function of NS in perspective of single objective nonlinear JPCP problem Here we have formulated a non-linear JPCP design .In this test problem, we find out minimum thickness ,radius of relative stiffness ,initial number of axle due to single and tandem axle per day in year according to modulus of subgrade reaction. The comparisons of results obtained for the undertaken problem clearly show the superiority of neutrosophic

optimization over PCA. The results of this study may lead to the development of effective neutrosophic technique for solving other model of nonlinear programming problem in different field.

# CHAPTER 11

---

## Multi-Objective Structural Design Optimization Based on Neutrosophic Goal Programming Technique

---

The research area of optimal structural design has been receiving increasing attention from both academia and industry over the past four decades in order to improve structural performance and to reduce design costs. In the real world, uncertainty or vagueness is prevalent in the Engineering Computations. In the context of structural design the uncertainty is connected with lack of accurate data of design factors. This tendency has been changing due to the increase in the use of fuzzy mathematical algorithm for dealing with such kind of problems.

Fuzzy set (FS) theory has long been introduced to deal with inexact and imprecise data by Zadeh [1], Later on the fuzzy set theory was used by Bellman and Zadeh [58] to the decision making problem. A few work has been done as an application of fuzzy set theory on structural design. Several researchers like Wang et al. [119] first applied  $\alpha$ -cut method to structural designs where various design levels  $\alpha$  were used to solve the non-linear problems. In this regard ,a generalized fuzzy number has been used Dey et al. [32] in context of a non-linear structural design optimization. Dey et al.[34]used basic t-norm based fuzzy optimization technique for optimization of structure and Dey et al. [33] developed parameterized t-norm based fuzzy optimization method for optimum structural design.

In such extension, Intuitionistic fuzzy set which is one of the generalizations of fuzzy set theory and was characterized by a membership, a non- membership and a hesitancy function was first introduced by Atanassov [1] (IFS). In fuzzy set theory the degree of acceptance is only considered but in case of IFS it is characterized by degree of membership and non-membership in such a way that their sum is less or equal to one. Dey et al. [35]solved two bar truss non-linear problem by using intuitionistic fuzzy optimization problem.Again Dey et al. [36] used intuitionistic fuzzy optimization technique to solve multi objective structural design. R-x Liang et al[66] applied interdependent inputs of single valued trapezoidal neutrosophic information on Multi-criteria group decision making problem. P Ji et al. [10],S Yu et al. [132] did so many research study on application based neutrosophic sets and intuitionistic linguistic number . Z-p Tian et al.[115]Simplified neutrosophic linguistic multi-

criteria group decision-making approach to green product development. Again J-j Peng et al.[85] introduced multi-valued neutrosophic qualitative flexible approach based on likelihood for multi-criteria decision-making problems. Also H Zhang et. al [58] investigates a case study on a novel decision support model for satisfactory restaurants utilizing social information. P Ji et al. [135] developed a projection-based TODIM method under multi-valued neutrosophic environments and its application in personnel selection.

Intuitionistic fuzzy sets consider both truth and falsity membership and can only handle incomplete information but not the information which is connected with indeterminacy or inconsistency.

In neutrosophic sets indeterminacy or inconsistency is quantified explicitly by indeterminacy membership function. Neutrosophic Set (NS), introduced by Smarandache [94] was characterized by truth, falsity and indeterminacy membership so that in case of single valued NS set their sum is less or equal to three. In early [24] Charnes and Cooper first introduced Goal programming problem for a linear model. Usually conflicting goal are presented in a multi-objective goal programming problem. Dey et al[41] used intuitionistic goal programming on nonlinear structural model. This is the first time NSGO technique is in application to multi-objective structural design. Usually objective goals of existing structural model are considered to be deterministic and a fixed quantity. In a situation, the decision maker can be doubtful with regard to accomplishment of the goal. The DM may include the idea of truth, indeterminacy and falsity bound on objectives goal. The goal may have a target value with degree of truth, indeterminacy as well as degree of falsity. Precisely, we can say a human being that express degree of truth membership of a given element in a fuzzy set, truth and falsity membership in a intuitionistic fuzzy set, very often does not express the corresponding degree of falsity membership as complement to 3. This fact seems to take the objective goal as a neutrosophic set. The present study investigates computational algorithm for solving multi-objective structural problem by single valued generalized NSGO technique. The results are compared numerically for different aggregation method of NSGO technique. From our numerical result, it has been seen that the best result obtained for geometric aggregation method for NSGO technique in the perspective of structural optimization technique.

### **11.1 Multi-objective Structural Model**

In the design problem of the structure i.e. lightest weight of the structure and minimum deflection of the loaded joint that satisfies all stress constraints in members of the structure.

In truss structure system ,the basic parameters (including allowable stress,etc.) are known and the optimization's target is that identify the optimal bar truss cross-section area so that the structure is of the smallest total weight with minimum nodes displacement in a given load conditions .

The multi-objective structural model can be expressed as

**(P11.1)**

$$\text{Minimize } WT(A) \tag{11.1}$$

$$\text{minimize } \delta(A) \tag{11.2}$$

$$\text{subject to } \sigma(A) \leq [\sigma] \tag{11.3}$$

$$A^{\min} \leq A \leq A^{\max} \tag{11.4}$$

where  $A = [A_1, A_2, \dots, A_n]^T$  are the design variables for the cross section, n is the group number of design variables for the cross section bar ,  $WT(A) = \sum_{i=1}^n \rho_i A_i L_i$  is the total weight of the structure ,  $\delta(A)$  is the deflection of the loaded joint ,where  $L_i, A_i$  and  $\rho_i$  are the bar length, cross section area and density of the  $i^{th}$  group bars respectively.  $\sigma(A)$  is the stress constraint and  $[\sigma]$  is allowable stress of the group bars under various conditions,  $A^{\min}$  and  $A^{\max}$  are the lower and upper bounds of cross section area A respectively.

## 11.2 Solution of Multi-objective Structural Optimization Problem (MOSOP) by Generalized Neutrosophic Goal Optimization Technique

The multi-objective neutrosophic fuzzy structural model can be expressed as

**(P11.2)**

$$\begin{aligned} &\text{Minimize } WT(A) \text{ with target value } WT_0, \text{ truth tolerance } a_{WT}, \text{ indeterminacy tolerance } d_{WT} \\ &\text{and rejection tolerance } c_{WT} \end{aligned} \tag{11.5}$$

$$\begin{aligned} &\text{Minimize } \delta(A) \text{ with target value } \delta_0, \text{ truth tolerance } a_{\delta_0}, \text{ indeterminacy tolerance } d_{\delta_0} \text{ and} \\ &\text{rejection tolerance } c_{\delta_0} \end{aligned} \tag{11.6}$$

$$\text{subject to } \sigma(A) \leq [\sigma] \tag{11.7}$$



$$A^{\min} \leq A \leq A^{\max} \quad (11.8)$$

where  $A = [A_1, A_2, \dots, A_n]^T$  are the design variables for the cross section,  $n$  is the group number of design variables for the cross section bar.

To solve this problem we first calculate truth, indeterminacy and falsity membership function of objective as follows

$$T_{WT}^{w_1}(WT(A)) = \begin{cases} w_1 & \text{if } WT(A) \leq WT_0 \\ w_1 \left( \frac{WT_0 + a_{WT} - WT(A)}{a_{WT}} \right) & \text{if } WT_0 \leq WT(A) \leq WT_0 + a_{WT} \\ 0 & \text{if } WT(A) \geq WT_0 + a_{WT} \end{cases} \quad (11.9)$$

$$I_{WT(A)}^{w_2}(WT(A)) = \begin{cases} 0 & \text{if } WT(A) \leq WT_0 \\ w_2 \left( \frac{WT(A) - WT_0}{d_{WT}} \right) & \text{if } WT_0 \leq WT(A) \leq WT_0 + a_{WT} \\ w_2 \left( \frac{WT_0 + a_{WT} - WT(A)}{a_{WT} - d_{WT}} \right) & \text{if } WT_0 + d_{WT} \leq WT(A) \leq WT_0 + a_{WT} \\ 0 & \text{if } WT(A) \geq WT_0 + a_{WT} \end{cases}$$

(11.10)

$$\text{where } d_{WT} = \frac{w_1}{\frac{w_1}{a_{WT}} + \frac{w_2}{c_{WT}}}$$

$$F_{WT(A)}^{w_3}(WT(A)) = \begin{cases} 0 & \text{if } WT(A) \leq WT_0 \\ w_3 \left( \frac{WT(A) - WT_0}{c_{WT}} \right) & \text{if } WT_0 \leq WT(A) \leq WT_0 + c_{WT} \\ w_3 & \text{if } WT(A) \geq WT_0 + c_{WT} \end{cases} \quad (11.11)$$

And

$$T_{\delta(A)}^{w_1}(\delta(A)) = \begin{cases} w_1 & \text{if } \delta(A) \leq \delta_0 \\ w_1 \left( \frac{\delta_0 + a_{\delta_0} - \delta(A)}{a_{\delta_0}} \right) & \text{if } \delta_0 \leq \delta(A) \leq \delta_0 + a_{\delta_0} \\ 0 & \text{if } \delta(A) \geq \delta_0 + a_{\delta_0} \end{cases} \quad (11.12)$$

$$I_{\delta(A)}^{w_2}(\delta(A)) = \begin{cases} 0 & \text{if } \delta(A) \leq \delta_0 \\ w_2 \left( \frac{\delta(A) - \delta_0}{d_\delta} \right) & \text{if } \delta_0 \leq \delta(A) \leq \delta_0 + a_\delta \\ w_2 \left( \frac{\delta_0 + a_\delta - WT(A)}{a_\delta - d_\delta} \right) & \text{if } \delta_0 + d_\delta \leq \delta(A) \leq \delta_0 + a_\delta \\ 0 & \text{if } \delta(A) \geq \delta_0 + a_\delta \end{cases} \quad (11.13)$$

$$d_\delta = \frac{w_1}{\frac{w_1}{a_\delta} + \frac{w_2}{c_\delta}} \quad (11.14)$$

$$F_{\delta(A)}^{w_3}(\delta(A)) = \begin{cases} 0 & \text{if } \delta(A) \leq \delta_0 \\ w_3 \left( \frac{\delta(A) - \delta_0}{c_\delta} \right) & \text{if } \delta_0 \leq \delta(A) \leq \delta_0 + c_\delta \\ w_3 & \text{if } \delta(A) \geq \delta_0 + c_\delta \end{cases} \quad (11.15)$$

According to generalized neutrosophic goal optimization technique using truth, indeterminacy and falsity membership function, MOSOP (P11.1) can be formulated as

**(P11.3)**

**Model -I**

$$\text{Maximize } \alpha, \text{Maximize } \gamma, \text{Minimize } \beta \quad (11.16)$$

$$WT(A) \leq WT_0 + a_{WT} \left( 1 - \frac{\alpha}{w_1} \right), \quad (11.17)$$

$$WT(A) \geq WT_0 + \frac{d_{WT}}{w_2} \gamma, \quad (11.18)$$

$$WT(A) \leq WT_0 + a_{WT} - \frac{\gamma}{w_2} (a_{WT} - d_{WT}), \quad (11.19)$$

$$WT(A) \leq WT_0 + \frac{c_{WT}}{w_3} \beta, \quad (11.20)$$

$$WT(A) \leq WT_0, \quad (11.21)$$

$$\delta(A) \leq \delta_0 + a_\delta \left( 1 - \frac{\alpha}{w_1} \right), \quad (11.22)$$

$$\delta(A) \geq \delta_0 + \frac{d_\delta}{w_2} \gamma, \quad (11.23)$$

$$\delta(A) \leq \delta_0 + a_\delta - \frac{\gamma}{w_2}(a_\delta - d_\delta), \quad (11.24)$$

$$\delta(A) \leq \delta_0 + \frac{c_\delta}{w_3} \beta, \quad (11.25)$$

$$\delta(A) \leq \delta_0, \quad (11.26)$$

$$0 \leq \alpha + \beta + \gamma \leq w_1 + w_2 + w_3; \quad (11.27)$$

$$\alpha \in [0, w_1], \gamma \in [0, w_2], \beta \in [0, w_3];$$

$$w_1 \in [0, 1], w_2 \in [0, 1], w_3 \in [0, 1];$$

$$0 \leq w_1 + w_2 + w_3 \leq 3; \quad (11.28)$$

$$g_j(x) \leq b_j, j = 1, 2, \dots, m \quad (11.29)$$

$$x_j \geq 0, j = 1, 2, \dots, n \quad (11.30)$$

With the help of generalized truth, indeterminacy, falsity membership function the generalized neutrosophic goal programming based on arithmetic aggregation operator can be formulated as

**(P11.4)**

**Model -II**

$$\text{Minimize } \left\{ \frac{(1-\alpha) + \beta + (1-\gamma)}{3} \right\} \quad (11.31)$$

Subjected to the same constraint as (P11.3)

With the help of generalized truth, indeterminacy, falsity membership function the generalized neutrosophic goal programming based on geometric aggregation operator can be formulated as

**(P11.5)**

**Model -III**

$$\text{Minimize } \sqrt[3]{(1-\alpha)\beta(1-\gamma)} \quad (11.32)$$

Subjected to the same constraint as (P11.3)

Now these non-linear programming Model-I,II,III can be easily solved through an appropriate mathematical programming to give solution of multi-objective non-linear programming problem (P11.1) by generalized neutrosophic goal optimization approach.

### 11.3 Numerical Illustration

A well-known three bar planer truss is considered in Fig.-11.1 to minimize weight of the structure  $WT(A_1, A_2)$  and minimize the deflection  $\delta(A_1, A_2)$  at a loading point of a statistically loaded three bar planer truss subject to stress constraints on each of the truss members

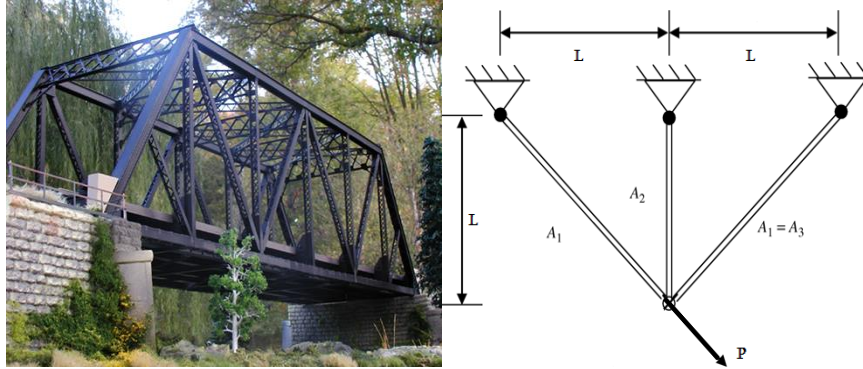

**Fig.-11.1 Design of the Three-Bar Planar Truss(Pratt Truss Bridge,**  
<http://www.atlaso.com>, accessed on 17 June 2017)

The multi-objective optimization problem can be stated as follows

**(P11.6)**

$$\text{Minimize } WT(A_1, A_2) = \rho L(2\sqrt{2}A_1 + A_2) \quad (11.33)$$

$$\text{Minimize } \delta(A_1, A_2) = \frac{PL}{E(A_1 + \sqrt{2}A_2)} \quad (11.34)$$

Subject to

$$\sigma_1(A_1, A_2) = \frac{P(\sqrt{2}A_1 + A_2)}{(\sqrt{2}A_1^2 + 2A_1A_2)} \leq [\sigma_1^T]; \quad (11.35)$$

$$\sigma_2(A_1, A_2) = \frac{P}{(A_1 + \sqrt{2}A_2)} \leq [\sigma_2^T]; \quad (11.37)$$

$$\sigma_3(A_1, A_2) = \frac{PA_2}{(\sqrt{2}A_1^2 + 2A_1A_2)} \leq [\sigma_3^C]; \quad (11.38)$$

$$A_i^{\min} \leq A_i \leq A_i^{\max} \quad i = 1, 2$$

where  $P$  = applied load ;  $\rho$  = material density ;  $L$  = length ;  $E$  = Young's modulus ;  $A_1$  = Cross section of bar-1 and bar-3;  $A_2$  = Cross section of bar-2;  $\delta$  is deflection of loaded joint.  $[\sigma_1^T]$  and  $[\sigma_2^T]$  are maximum allowable tensile stress for bar 1 and bar 2 respectively,  $\sigma_3^C$  is maximum allowable compressive stress for bar 3. The input data is given in table 1.

**Table 11.1 Input data for crisp model (P11.6)**

Applied load $P$ (KN)	Volume density $\rho$ (KN/m <sup>3</sup> )	Length $L$ (m)	Maximum allowable tensile stress $[\sigma^T]$ (KN/m <sup>2</sup> )	Maximum allowable compressive stress $[\sigma^C]$ (KN/m <sup>2</sup> )	Young's modulus $E$ (KN/m <sup>2</sup> )	$A_i^{\min}$ and $A_i^{\max}$ of cross section of bars (10 <sup>-4</sup> m <sup>2</sup> )
20	100	1	20	15	$2 \times 10^7$	$A_1^{\min} = 0.1$ $A_1^{\max} = 5$ $A_2^{\min} = 0.1$ $A_2^{\max} = 5$

This multi objective structural model can be expressed as neutrosophic fuzzy model as

**(P11.7)**

Minimize  $WT(A_1, A_2) = \rho L(2\sqrt{2}A_1 + A_2)$  with target value  $4 \times 10^2$  KN ,truth tolerance

$2 \times 10^2$  KN ,indeterminacy tolerance  $\frac{w_1}{0.5w_1 + 0.22w_2} \times 10^2$  KN and rejection tolerance

$$4.5 \times 10^2 \text{ KN} \tag{11.39}$$

Minimize  $\delta(A_1, A_2) = \frac{PL}{E(A_1 + \sqrt{2}A_2)}$  with target value  $2.5 \times 10^{-7}$  m ,truth tolerance

$2.5 \times 10^{-7}$  m ,indeterminacy tolerance  $\frac{w_1}{0.4w_1 + 0.22w_2} \times 10^{-7}$  m and rejection tolerance

$$4.5 \times 10^{-7} \text{ m} \tag{11.40}$$

Subject to

$$\sigma_1(A_1, A_2) = \frac{P(\sqrt{2}A_1 + A_2)}{(\sqrt{2}A_1^2 + 2A_1A_2)} \leq [\sigma_1^T]; \tag{11.41}$$

$$\sigma_2(A_1, A_2) = \frac{P}{(A_1 + \sqrt{2}A_2)} \leq [\sigma_2^T]; \quad (11.42)$$

$$\sigma_3(A_1, A_2) = \frac{PA_2}{(\sqrt{2}A_1^2 + 2A_1A_2)} \leq [\sigma_3^C];$$

(11.43)

$$A_i^{\min} \leq A_i \leq A_i^{\max} \quad i = 1, 2 \quad (11.44)$$

According to generalized neutrosophic goal optimization technique using truth, indeterminacy and falsity membership function, MOSOP (P11.6) can be formulated as

**(P11.8)**

**Model -I**

$$\text{Maximize } \alpha, \text{Maximize } \gamma, \text{Minimize } \beta \quad (11.45)$$

$$(2\sqrt{2}A_1 + A_2) \leq 4 + 2\left(1 - \frac{\alpha}{w_1}\right), \quad (11.46)$$

$$(2\sqrt{2}A_1 + A_2) \geq 4 + \frac{w_1}{w_2(0.5w_1 + 0.22w_2)} \gamma, \quad (11.47)$$

$$(2\sqrt{2}A_1 + A_2) \leq 4 + 2 - \frac{\gamma}{w_2} \left(2 - \frac{w_1}{(0.5w_1 + 0.22w_2)}\right), \quad (11.48)$$

$$(2\sqrt{2}A_1 + A_2) \leq 4 + \frac{4.5}{w_3} \beta, \quad (11.49)$$

$$(2\sqrt{2}A_1 + A_2) \leq 4, \quad (11.50)$$

$$\frac{20}{(A_1 + \sqrt{2}A_2)} \leq 2.5 + 2.5\left(1 - \frac{\alpha}{w_1}\right), \quad (11.51)$$

$$\frac{20}{(A_1 + \sqrt{2}A_2)} \geq 2.5 + \frac{w_1}{w_2(0.4w_1 + 0.22w_2)} \gamma, \quad (11.52)$$

$$\frac{20}{(A_1 + \sqrt{2}A_2)} \leq 2.5 + 2.5 - \frac{\gamma}{w_2} \left(2.5 - \frac{w_1}{(0.4w_1 + 0.22w_2)}\right), \quad (11.53)$$

$$\frac{20}{(A_1 + \sqrt{2}A_2)} \leq 2.5 + \frac{4.5}{w_3} \beta, \quad (11.54)$$

$$\frac{20}{(A_1 + \sqrt{2}A_2)} \leq 2.5, \quad (11.55)$$

$$0 \leq \alpha + \beta + \gamma \leq w_1 + w_2 + w_3; \quad (11.56)$$

$$\alpha \in [0, w_1], \gamma \in [0, w_2], \beta \in [0, w_3];$$

$$w_1 \in [0, 1], w_2 \in [0, 1], w_3 \in [0, 1];$$

$$0 \leq w_1 + w_2 + w_3 \leq 3; \quad (11.57)$$

$$\frac{20(\sqrt{2}A_1 + A_2)}{(\sqrt{2}A_1^2 + 2A_1A_2)} \leq 20; \quad (11.58)$$

$$\frac{20}{(A_1 + \sqrt{2}A_2)} \leq 20; \quad (11.59)$$

$$\frac{20A_2}{(\sqrt{2}A_1^2 + 2A_1A_2)} \leq 15; \quad (11.60)$$

$$0.1 \leq A_i \leq 5 \quad i = 1, 2 \quad (11.61)$$

With the help of generalized truth, indeterminacy, falsity membership function the generalized neutrosophic goal programming problem (P11.6) based on arithmetic aggregation operator can be formulated as

**(P11.9)**

**Model -II**

$$\text{Minimize } \left\{ \frac{(1-\alpha) + \beta + (1-\gamma)}{3} \right\} \quad (11.62)$$

Subjected to the same constraint as (P11.8)

With the help of generalized truth, indeterminacy, falsity membership function the generalized neutrosophic goal programming problem (P11.6) based on geometric aggregation operator can be formulated as

**(P11.10)**

**Model -III**

$$\text{Minimize } \sqrt[3]{(1-\alpha)\beta(1-\gamma)} \quad (11.63)$$

Subjected to the same constraint as (P11.8)

The above problem can be formulated using Model-I,II,III and can be easily solved by an appropriate mathematical programming to give solution of multi-objective non-linear programming problem (P11.6) by generalized neutrosophic goal optimization approach and the results are shown in the table 11.2. Again value of membership function in GNGP technique for MOSOP (P11.6) based on different Aggregation is given in Table 11.3.

**Table 11.2 Comparison of GNGP solution of MOSOP (P11.6) based on different Aggregation**

Methods	$A_1$ $\times 10^{-4} m^2$	$A_2$ $\times 10^{-4} m^2$	$WT(A_1, A_2)$ $\times 10^2 KN$	$\delta(A_1, A_2)$ $\times 10^{-7} m$
Generalized Fuzzy Goal programming (GFGP) $w_1 = 0.15$	0.5392616	4.474738	6	2.912270
Generalized Intuitionistic Fuzzy Goal programming (GIFGP) $w_1 = 0.15$ $w_3 = 0.8$	0.5392619	4.474737	6	2.912270
Generalized Neutrosophic Goal programming (GNGP) $w_1 = 0.4, w_2 = 0.3, w_3 = 0.7$	5	0.4321463	4.904282	3.564332
Generalized Intuitionistic Fuzzy optimization (GIFGP) based on Arithmetic Aggregation $w_1 = 0.15, w_3 = 0.8$	0.5392619	4.474737	6	2.912270
Generalized Neutrosophic optimization (GNGP) based on Arithmetic Aggregation $w_1 = 0.4, w_2 = 0.3, w_3 = 0.7$	5	0.4321468	4.904282	3.564333
Generalized Intuitionistic Fuzzy optimization (GIFGP) based on Geometric Aggregation $w_1 = 0.15, w_3 = 0.8$	0.5727008	2.380158	4	5.077751
Generalized Neutrosophic optimization (GNGP) based on Geometric Aggregation $w_1 = 0.4, w_2 = 0.3, w_3 = 0.7$	5	1.109954	4.462428	3.044273

Here we get best solutions for the different value of  $w_1, w_2, w_3$  in geometric aggregation method for objective functions. From Table 11.2 it is clear that Neutrosophic Optimization technique is more fruitful in optimization of weight compare to fuzzy and intuitionistic fuzzy optimization technique. Moreover it has been seen that more desired value is obtain in



geometric aggregation method compare to arithmetic aggregation method in intuitionistic as well as neutrosophic environment in perspective of structural engineering.

**Table 11.3 Value of membership function in GNGP technique for MOSOP (P11.6) based on different Aggregation**

Methods	$\alpha^*, \beta^*, \gamma^*$	Sum of Truth, Indeterminacy and Falsity Membership Function
Neutrosophic Goal programming (GNGP) $w_1 = 0.4, w_2 = 0.3, w_3 = 0.7$	$\alpha^* = .1814422$ $\beta^* = .2191435$ $\gamma^* = .6013477$	$T_{WT}(WT(A_1, A_2)) + I_{WT}(WT(A_1, A_2)) + F_{WT}(WT(A_1, A_2))$ $= .2191435 + .1804043 + .1406661 = .5402139$ $T_{\delta}(\delta(A_1, A_2)) + I_{\delta}(\delta(A_1, A_2)) + F_{\delta}(\delta(A_1, A_2))$ $= .2297068 + .1804043 + .1655628 = .5756739$
Generalized Neutrosophic optimization (GNGP) based on Arithmetic Aggregation $w_1 = 0.4, w_2 = 0.3, w_3 = 0.7$	$\alpha^* = .2191435$ $\beta^* = .2191435$ $\gamma^* = .6013480$	$T_{WT}(WT(A_1, A_2)) + I_{WT}(WT(A_1, A_2)) + F_{WT}(WT(A_1, A_2))$ $= .2191435 + .1804044 + .1406662 = .5402141$ $T_{\delta}(\delta(A_1, A_2)) + I_{\delta}(\delta(A_1, A_2)) + F_{\delta}(\delta(A_1, A_2))$ $= .2297068 + .1804044 + .1655629 = .5756741$
Generalized Neutrosophic optimization (GNGP) based on Geometric Aggregation $w_1 = 0.4, w_2 = 0.3, w_3 = 0.7$	$\alpha^* = .3075145$ $\beta^* = .3075145$ $\gamma^* = .3075145$	$T_{WT}(WT(A_1, A_2)) + I_{WT}(WT(A_1, A_2)) + F_{WT}(WT(A_1, A_2))$ $= .3075145 + .0922543 + .07193320 = .471702$ $T_{\delta}(\delta(A_1, A_2)) + I_{\delta}(\delta(A_1, A_2)) + F_{\delta}(\delta(A_1, A_2))$ $= .3129163 + .09225434 + .08466475 = .48983539$

From the above table it is clear that all the objective functions are attain their goals as well as restriction of truth, indeterminacy and falsity membership function in neutrosophic goal programming problem based on different aggregation operator. The sum of truth, indeterminacy and falsity membership function for each objective is less than sum of gradation ( $w_1 + w_2 + w_3$ ). Hence the criteria of generalized neutrosophic set is satisfied.

## 11.4 Conclusion

The research study investigates that neutrosophic goal programming can be utilized to optimize a nonlinear structural problem. The results obtained for different aggregation method of the undertaken problem show that the best result is achieved using geometric aggregation method. The concept of neutrosophic optimization technique allows one to define a degree of truth membership, which is not a complement of degree of falsity; rather, they are independent with degree of indeterminacy. As we have considered a non-linear three bar truss design problem and find out minimum weight of the structure as well as minimum

deflection of loaded joint, the results of this study may lead to the development of effective neutrosophic technique for solving other model of nonlinear programming problem in different field.

# CHAPTER 12

---

## Multi-objective Cylindrical Skin Plate Design Optimization based on Neutrosophic Optimization Technique

---

Structural optimization is an important notion in civil engineering. Traditionally structural optimization is a well known concept and in many situations it is treated as single objective form, where the objective is known the weight function. The extension of this is the optimization where one or more constraints are simultaneously satisfied next to the minimization of the weight function. This does not always hold good in real world problems where multiple and conflicting objectives frequently exist. In this consequence a methodology known as multi-objective structural optimization (MOSO) is introduced. In structural engineering design problems, the input data and parameters are often fuzzy/imprecise with nonlinear characteristics that necessitate the development of fuzzy optimum structural design method. Fuzzy set (FS) theory has long been introduced to handle inexact and imprecise data by Zadeh [133]. Later on Bellman and Zadeh [10] used the fuzzy set theory to the decision making problem. The fuzzy set theory also found application in structural design. Several researchers like Wang et al. [119] first applied  $\alpha$ -cut method to structural designs where the non-linear problems were solved with various design levels  $\alpha$ , and then a sequence of solutions were obtained by setting different level-cut value of  $\alpha$ . Rao [89] applied the same  $\alpha$ -cut method to design a four-bar mechanism for function generating problem. Structural optimization with fuzzy parameters was developed by Yeh et al. [132] Xu [13] used two-phase method for fuzzy optimization of structures. Shih et al. [95] used level-cut approach of the first and second kind for structural design optimization problems with fuzzy resources. Shih et al [96] developed an alternative  $\alpha$ -level-cuts methods for optimum structural design with fuzzy resources. Dey et al. [32] used generalized fuzzy number in context of a structural design. Dey et al. [33] developed parameterized t-norm based fuzzy optimization method for optimum structural design. Also, Dey et al. [34] Optimized shape design of structural model with imprecise coefficient by parametric geometric programming. In such extension, Atanassov [1] introduced Intuitionistic fuzzy set (IFS) which is one of the generalizations of fuzzy set theory and is characterized by a membership function, a non membership function and a hesitancy function. In fuzzy sets the degree of acceptance is only considered but IFS is characterized by a membership function and a non-membership function so that the sum of both values is less than one. A transportation model was solved by Jana et al [57] using multi-objective intuitionistic fuzzy linear programming. Dey et al. [35] solved two bar truss non linear problem by using intuitionistic fuzzy optimization problem. Dey et al. [31] used intuitionistic fuzzy optimization technique for multi objective optimum structural design. Intuitionistic fuzzy sets consider both truth membership and falsity membership. Intuitionistic fuzzy sets can only handle incomplete information not the indeterminate information and inconsistent information. In neutrosophic sets indeterminacy is quantified explicitly and truth membership, indeterminacy membership and falsity membership which are independent. Neutrosophic theory was introduced by Smarandache [94]. The motivation of the present study is to give computational algorithm for solving multi-objective structural problem by single valued neutrosophic optimization approach. Neutrosophic optimization technique is very rare in application to structural optimization. We also aim to study the impact of truth membership,

indeterminacy membership and falsity membership function in such optimization process. The results are compared numerically both in fuzzy optimization technique, intuitionistic fuzzy optimization technique and neutrosophic optimization technique. From our numerical result, it is clear that neutrosophic optimization technique provides better results than fuzzy optimization and intuitionistic fuzzy optimization.

## 12.1 Multi-objective Structural Model Formulation

In the design problem of the structure i.e. lightest thickness of the structure and minimum sag that satisfies all stress and deflection constraints in members of the structure. In vertical lift gate structural system, the basic parameters (including allowable stress, deflection etc) are known and the optimization's target is that identify the optimal thickness and sag so that the structure is of the smallest total weight with minimum stress and deflection in a given load conditions.

The multi-objective structural model can be expressed as

(P12.1)

$$\text{Minimize } G \quad (12.1)$$

$$\text{Minimize } S \quad (12.2)$$

$$\text{subject to } \sigma \leq [\sigma] \quad (12.3)$$

$$\delta \leq [\delta] \quad (12.4)$$

$$G^{\min} \leq G \leq G^{\max} \quad (12.5)$$

$$S^{\min} \leq S \leq S^{\max} \quad (12.6)$$

where  $G$  and  $S$  are the design variables for the structural design,  $\delta$  is the deflection of the vertical lift gate of skin plate due to hydraulic load.  $\sigma$  is the stress constraint and  $[\sigma]$ ,  $[\delta]$  are allowable stress of the vertical lift gate of skin plate under various conditions.  $G^{\min}$  and  $S^{\min}$ ,  $G^{\max}$  and  $S^{\max}$  are the lower and upper bounds of design variables respectively.

## 12.2 Solution of Multi-objective Structural Optimization Problem (MOSOP) by Neutrosophic Optimization Technique

To solve the MOSOP (P12.1), step 1 of 1.30 is used. After that according to step to pay off matrix is formulated.

$$G \quad S \\ G^1 \begin{bmatrix} G^1 & S^1 \\ T^2 & S^2 \end{bmatrix}$$

According to step-2 the bound of weight objective  $U_G^T, L_G^T; U_G^I, L_G^I$  and  $U_G^F, L_G^F$  for truth, indeterminacy and falsity membership function respectively. Then

$L_G^T \leq G \leq U_G^T; L_G^F \leq G \leq U_G^F; L_G^I \leq G \leq U_G^I$ . Similarly the bound of deflection objective are  $U_S^T, L_S^T; U_S^F, L_S^F$  and  $U_S^I, L_S^I$  are respectively for truth, indeterminacy and falsity membership function.

Then  $L_S^T \leq S \leq U_S^T; L_S^F \leq S \leq U_S^F; L_S^I \leq S \leq U_S^I$ . Where  $U_G^F = U_G^T; L_G^F = L_G^T + \varepsilon_G; L_G^I = L_G^T, U_G^I = L_G^T + \varepsilon_G$

and  $U_S^F = U_S^T; L_S^F = L_S^T + \xi_S; L_S^I = L_S^T; U_S^I = L_S^T + \xi_S$  such that

$$0 < \varepsilon_G < (U_G^T - L_G^T) \text{ and } 0 < \xi_S < (U_S^T - L_S^T).$$

According to neutrosophic optimization technique considering truth, indeterminacy and falsity membership function for MOSOP (P12.1), crisp non-linear programming problem can be formulated as

**(P12.2)**

Maximize  $(\alpha + \gamma - \beta)$

subject to

$$T_G \geq \alpha; T_S \geq \alpha; F_G \leq \beta; F_S \leq \beta;$$

$$I_G \geq \gamma; I_S \geq \gamma; \sigma \leq [\sigma]; \delta \leq [\delta];$$

$$\alpha + \beta + \gamma \leq 3; \alpha \geq \beta; \alpha \geq \gamma;$$

$$\alpha, \beta, \gamma \in [0,1], \quad G^{\min} \leq G \leq G^{\max} \quad S^{\min} \leq S \leq S^{\max}$$

Solving the above crisp model (6) by an appropriate mathematical programming algorithm we get optimal solution and hence objective functions i.e structural weight and deflection of the loaded joint will attain Pareto optimal solution.

### 12.3 Numerical Illustration

A cylindrical skin plate of vertical lift gate (Guha A.L et al [49]) in Fig-12.1 has been considered. The weight of the skin plate is about 40% of the weight of the vertical lift gate, thus the minimum weight of the vertical lift gate can be achieved by using minimum thickness of a skin plate with same number of horizontal girders for the particular hydraulic load. It is proposed to replace stiffened flat skin plate by unstiffened cylindrical skin plate. The stress developed in skin plate and its distribution mainly depends on water head, skin plate thickness, and sag and position of Horizontal girders. Stress and deflection are expressed in terms of water head, skin plate thickness, and sag based on finite element analysis.

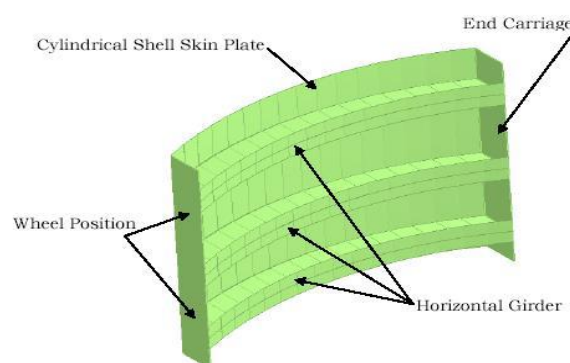

**Fig.-12.1 Vertical lift gate with cylindrical shell type skin plate**

The proposed expressions are furnished as stress  $\sigma(G,S,H) = K_1 G^{-n_1} S^{-n_2} H^{n_3}$  where,  $\sigma$  = stress in  $\text{Kg/cm}^2$ ;  $H$  = water Head in ‘m’  $G$  = Thickness in ‘mm’  $S$  = Sag in ‘mm’

$K_1$  = constant of variation and  $n_1$ ;  $n_2$  and  $n_3$  = constants depend on the properties of material

Similarly, deflection  $\delta(G,S,H) = K_2 G^{-n_4} S^{-n_5} H^{n_6}$  where,  $K_2$  = constant of variation and

$n_4; n_5$  and  $n_6 =$  constants depend on the properties of material.

To minimize the weight of Vertical gate by simultaneous minimization of Thickness  $G$  and sag,  $S$  of skin plate subject to maximum allowable stress ( $\sigma_0$ ) and deflection ( $\delta_0$ ).

So the model is

**(P12.3)**

Minimize  $G$  (12.54)

Minimize  $S$  (12.55)

Subject to

$\sigma(G, S, H) \equiv K_1 G^{-n_1} S^{-n_2} H^{n_3} \leq \sigma_0;$  (12.56)

$\delta(G, S, H) \equiv K_2 G^{-n_4} S^{-n_5} H^{n_6} \leq \delta_0$  (12.57)

$G, S > 0;$

Input data of the problem is tabulated in Table.12. 1.

**Table 12.1 Input data for crisp model (P12.1)**

constant of variation $K_1$	constant of variation $K_2$	constants depend on the properties of material	water head $H$ (m)	Maximum allowable stress $\sigma_0$ (Mpa)	Maximum allowable deflection of girder $\delta_0$ (Mpa)
$3.79 \times 10^{-3}$	$87.6 \times 10^{-5}$	$n_1 = 0.44; n_2 = 1.58; n_3 = 1.0$ $n_4 = 0.729; n_5 = 0.895; n_6 = 1.0$	25	137.5	5.5

Solution : According to step 2 of 1.30, pay-off matrix is formulated as follows

$$\begin{matrix}
 & G & S \\
 G^1 & \begin{bmatrix} 0.59 \times 10^{-5} & 37.61824 \\ 3528.536 & 0.10256 \times 10^{-2} \end{bmatrix} \\
 S^2 & & 
 \end{matrix}$$

Here  $U_G^F = U_G^T = 3528.536, L_G^F = L_G^T + \varepsilon_G = 0.59 \times 10^{-5} + \varepsilon_G; L_G^L = L_G^T = 0.59 \times 10^{-5},$   
 $U_G^L = L_G^T + \xi_G = 0.59 \times 10^{-5} + \xi_G$

Such that  $0 < \varepsilon_G, \xi_G < (3528.536 - 0.59 \times 10^{-5});$

$U_S^F = U_S^T = 37.61824, L_S^F = L_S^T + \varepsilon_S = 0.10256 \times 10^{-2} + \varepsilon_S; L_S^L = L_S^T = 0.10256 \times 10^{-2},$   
 $U_S^L = L_S^T + \xi_S = 0.10256 \times 10^{-2} + \xi_S$

such that  $0 < \varepsilon_S, \xi_S < (37.61824 - 0.10256 \times 10^{-2})$

Here truth, indeterminacy, and falsity membership function for objective functions are  $G$  and  $S$  are defined as follows

$$T_G = \begin{cases} 1 & \text{if } G \leq 0.59 \times 10^{-5} \\ \frac{3528.536 - G}{3528.536 - 0.59 \times 10^{-5}} & \text{if } 0.59 \times 10^{-5} \leq G \leq 3528.536 \\ 0 & \text{if } G \geq 3528.536 \end{cases} \quad (12.58)$$

$$F_G = \begin{cases} 0 & \text{if } G \leq 0.59 \times 10^{-5} + \varepsilon_G \\ \frac{G - (0.59 \times 10^{-5} + \varepsilon_G)}{3528.536 - 0.59 \times 10^{-5} - \varepsilon_G} & \text{if } 0.59 \times 10^{-5} + \varepsilon_G \leq G \leq 3528.536; \\ 1 & \text{if } G \geq 3528.536 \end{cases} \quad (12.59)$$

$$I_G = \begin{cases} 1 & \text{if } G \leq 0.59 \times 10^{-5} \\ \frac{(0.59 \times 10^{-5} + \xi_G) - G}{\xi_G} & \text{if } 0.59 \times 10^{-5} \leq G \leq 0.59 \times 10^{-5} + \xi_G \\ 0 & \text{if } G \geq 0.59 \times 10^{-5} + \xi_G \end{cases} \quad (12.60)$$

$$T_S = \begin{cases} 1 & \text{if } S \leq 0.10256 \times 10^{-2} \\ \frac{37.61824 - S}{37.61824 - 0.10256 \times 10^{-2}} & \text{if } 0.10256 \times 10^{-2} \leq S \leq 37.61824; \\ 0 & \text{if } S \geq 37.61824 \end{cases} \quad (12.61)$$

$$F_S = \begin{cases} 0 & \text{if } S \leq 0.10256 \times 10^{-2} + \varepsilon_S \\ \frac{S - (0.10256 \times 10^{-2} + \varepsilon_S)}{37.61824 - 0.10256 \times 10^{-2} - \varepsilon_S} & \text{if } 0.10256 \times 10^{-2} + \varepsilon_S \leq S \leq 37.61824; \\ 1 & \text{if } S \geq 37.61824 \end{cases} \quad (12.62)$$

$$I_S = \begin{cases} 1 & \text{if } S \leq 0.10256 \times 10^{-2} \\ \frac{(0.10256 \times 10^{-2} + \xi_S) - S}{\xi_S} & \text{if } 0.10256 \times 10^{-2} \leq S \leq 0.10256 \times 10^{-2} + \xi_S \\ 0 & \text{if } S \geq 0.10256 \times 10^{-2} + \xi_S \end{cases} \quad (12.63)$$

Now using neutrosophic optimization technique with truth, indeterminacy and falsity membership functions we get

**(P12.4)**

$$\text{Maximize } (\alpha + \gamma - \beta) \quad (12.64)$$

$$\text{subject to } G + (3528.536 - 0.59 \times 10^{-5})\alpha \leq 3528.536; \quad (12.65)$$

$$S + (37.61824 - 0.10256 \times 10^{-2})\alpha \leq 37.61824; \quad (12.66)$$

$$G - (1 - \beta)(0.59 \times 10^{-5} + \varepsilon_G) \leq 3528.536\beta; \quad (12.67)$$

$$S - (1 - \beta)(0.10256 \times 10^{-2} + \varepsilon_S) \leq 37.61824\beta; \quad (12.68)$$

$$G + \xi_G \gamma \leq (0.59 \times 10^{-5} + \xi_G); \quad (12.69)$$

$$S + \xi_S \gamma \leq (0.10256 \times 10^{-2} + \xi_S); \quad (12.70)$$

$$(3.79 \times 10^{-3} \times 25) G^{-0.44} S^{-1.58} \leq 137.5; \quad (12.71)$$

$$(87.6 \times 10^{-5} \times 25) G^{-0.729} S^{-0.895} \leq 5.5; \quad (12.72)$$

$$\alpha \geq \beta; \quad (12.73)$$

$$\alpha \geq \gamma; \quad (12.74)$$

$$\alpha + \beta + \gamma \leq 3; \quad (12.75)$$

$$\alpha, \beta, \gamma \in [0, 1] \quad (12.76)$$

**Table 12.2 Comparison of Optimal solution of MOSOP (P12.1) based on different method**

Methods	<i>G</i> (mm)	<i>T</i> (mm)
Fuzzy multi-objective nonlinear programming (FMONLP)	52.88329	0.5648067
Intuitionistic fuzzy multi-objective nonlinear programming (IFMONLP) $\varepsilon_G = 1764.268, \varepsilon_S = 2.57033$	52.88329	0.5648065
Neutrosophic optimization (NSO) $\varepsilon_G = \xi_G = 1764.268, \varepsilon_S = \xi_S = 22.57033$	44.28802	0.5676034

Here we get best solutions for the different tolerance  $\xi_G, \xi_S$  for indeterminacy membership function of objective functions. From the Table 12.2, it shows that NSO technique gives better Pareto optimal result in the perspective of Structural Optimization.

#### 12.4 Conclusion

The main objective of this work is to illustrate how much neutrosophic optimization technique reduce thickness and sag of nonlinear vertical lift gate in comparison of fuzzy and intuitionistic fuzzy optimization technique. The concept of neutrosophic optimization technique allows one to define a degree of truth membership, which is not a complement of degree of falsity; rather, they are independent with degree of indeterminacy. Here we have considered a non-linear skin plate of vertical lift gate problem. In this problem, we find out minimum thickness of the structure as well as minimum sag of cylindrical skin plate. The comparisons of results obtained for the undertaken problem clearly show the superiority of neutrosophic optimization over fuzzy optimization and intuitionistic fuzzy optimization. The results of this study may lead to the development of effective neutrosophic technique for solving other model of nonlinear programming problem in different field.



## APPENDIX-A

### 13.1 Crisp Set

A set (crisp set) can be defined as the collection of well-defined distinct objects. For example if the set of odd positive real numbers in between 0 and 20 be denoted by  $A$ , then in tabular form it will be  $A = \{x : x = 2n, 0 < n < 10\}$  and in set builder form it will be  $A = \{2, 4, 6, 8, 10, 12, 14, 16, 18\}$

### 13.2 Fuzzy Set

A fuzzy set is an extension of the notion of crisp set such that their elements are characterized by their grade of membership and non-membership.

Fuzzy Sets are Introduced by Zadeh [133] as means of modelling problems and manipulating data that are not precise, in which the source of imprecisions is the absence of sharply defined criteria of class membership. Fuzzy set is an extension of crisp set i.e a classical set. Specially a fuzzy set on a classical set  $X$  is defined as follows

$$\tilde{A} = \{(x, \mu_{\tilde{A}}(x)) : x \in X\} \quad (13.1)$$

where  $\mu_{\tilde{A}}(x)$  is termed as the grade of membership of  $x$  in  $\tilde{A}$  and the function  $\mu_{\tilde{A}}(x) : X \rightarrow [0, 1]$  while assign the value 0, the member is not included in the given set and while it assign 1, the member is fully included. The value strictly lies between 0 and 1 characterized by the fuzzy numbers.

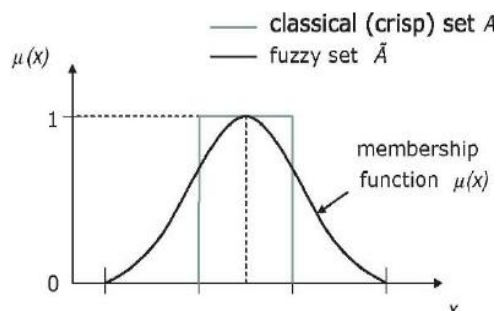

**Fig.-13.1 Rough Sketch of Crisp Set and Membership Function of Fuzzy Set**

In case of crisp set members are in the set with membership value 1 or out of the set the membership value 0. Thus crisp set  $\subseteq$  fuzzy set. In other word crisp set is the special case of

fuzzy set. For example if “tall women” is considered as a member in fuzzy set then it will be considered as a member in crisp set when it ranged with  $\geq 6$  ft . Similarly a point near 10 in fuzzy while be ranged with  $[9.8,10.3]$  then it will be considered as an member in crisp set.

### 13.3 Height of a Fuzzy Set

The height of a fuzzy set  $\tilde{A}$  on  $X$ , denoted by  $hgt(\tilde{A})$  is the least upper bound of  $\mu_{\tilde{A}}(x)$  i.e

$$hgt(\tilde{A}) = \sup_{x \in X} \mu_{\tilde{A}}(x)$$

(13.2)

### 13.4 Normal Fuzzy Set

A fuzzy set  $\tilde{A}$  is said to be normal if there exist at least one  $x \in X$  attaining the maximum membership grade 1 (i.e  $hgt(\tilde{A}) = 1$ ), otherwise it is subnormal. For optimized fuzzy set  $\tilde{A}$

$$\text{Max}_{x \in X} \mu_{\tilde{A}}(x) = 1 \quad (13.3)$$

### 13.5 $\alpha$ – Cut of Fuzzy Set

The  $\alpha$  – cut of the fuzzy set  $\tilde{A}$  on  $X$  is crisp set that contains all the element of  $X$  that have membership values in  $\tilde{A}$  greater than or equal to  $\alpha$ . i.e

$$A_{\alpha} = \{x : \mu_{\tilde{A}}(x) \geq \alpha, x \in X, \alpha \in [0,1]\} \quad (13.4)$$

### 13.6 Union of Two Fuzzy Sets

The union of two fuzzy sets  $\tilde{A}$  and  $\tilde{B}$  is a fuzzy set of  $X$ , denoted by  $\tilde{A} \cup \tilde{B}$  and is defined by the membership function

$$\mu_{\tilde{A} \cup \tilde{B}}(x) = \mu_{\tilde{A}}(x) \vee \mu_{\tilde{B}}(x) \text{ for each } x \in X \quad (13.5)$$

$$\text{so that } \tilde{A} \cup \tilde{B} = \{(x, \mu_{\tilde{A} \cup \tilde{B}}(x)) : \mu_{\tilde{A} \cup \tilde{B}}(x) = \max\{\mu_{\tilde{A}}(x), \mu_{\tilde{B}}(x)\}, \forall x \in X\} \quad (13.6)$$

$$\text{or } \tilde{A} \cup \tilde{B} = \int_{x \in X} \max\{\mu_{\tilde{A}}(x), \mu_{\tilde{B}}(x)\} / X \quad (13.7)$$

for any continuous fuzzy set  $\tilde{A}, \tilde{B}$ .

### 13.7 Intersection of Two Fuzzy Sets

The intersection of two fuzzy sets  $\tilde{A}$  and  $\tilde{B}$  is a fuzzy set of  $X$ , denoted by  $\tilde{A} \cap \tilde{B}$  and is defined by the membership function

$$\mu_{\tilde{A} \cap \tilde{B}}(x) = \mu_{\tilde{A}}(x) \wedge \mu_{\tilde{B}}(x) \text{ for each } x \in X \quad (13.8)$$

so that

$$\tilde{A} \cap \tilde{B} = \left\{ (x, \mu_{\tilde{A} \cap \tilde{B}}(x)) : \mu_{\tilde{A} \cap \tilde{B}}(x) = \min \{ \mu_{\tilde{A}}(x), \mu_{\tilde{B}}(x) \}, \forall x \in X \right\} \quad (13.9)$$

$$\tilde{A} \cap \tilde{B} = \int_{x \in X} \min \{ \mu_{\tilde{A}}(x), \mu_{\tilde{B}}(x) \} / X \quad (13.10)$$

for any continuous fuzzy set  $\tilde{A}, \tilde{B}$ .

### 13.8 Convex Fuzzy Set

A fuzzy set  $\tilde{A}$  of universe of  $X$  is convex if and only if for all  $x_1, x_2$  in  $X$

$$\mu_{\tilde{A}}(\lambda x_1 + (1-\lambda)x_2) \geq \min \{ \mu_{\tilde{A}}(x_1), \mu_{\tilde{A}}(x_2) \} \quad \text{when } 0 \leq \lambda \leq 1 \quad (13.11)$$

### 13.9 Interval Number

Interval analysis is a new and growing branch of applied mathematics. It provides necessary calculus called interval arithmetic for interval numbers. An interval number can be thought as an extension of the concept of a real number and also as a subset of real numbers. An interval number  $A$  is defined by an ordered pair of real numbers as follows

$$A = [a_L, a_R] = \{ x : a_L \leq x \leq a_R, x \in \mathcal{R} \} \quad (13.12)$$

where  $a_L$  and  $a_R$  the left and right bounds of interval  $A$  respectively The interval  $A$  is also defined by centre  $(a_c)$  and half width  $(a_w)$  as follows

$$A = \langle a_c, a_w \rangle = \{ x : a_c - a_w \leq x \leq a_c + a_w, x \in \mathcal{R} \} \quad (13.14)$$

where  $a_c = \frac{a_R + a_L}{2}$  is the centre and  $a_w = \frac{a_R - a_L}{2}$  is the half width of  $A$ .

The addition of two interval numbers  $A = [a_L, a_R]$  and  $B = [b_L, b_R]$  is defined as

$$A + B = [a_L, a_R] + [b_L, b_R] = [a_L + b_L, a_R + b_R] \quad (13.15)$$

$$\text{or } A + B = \langle a_c + a_w \rangle + \langle b_c + b_w \rangle = \langle a_c + b_c, a_w + b_w \rangle \quad (13.16)$$

Similarly the multiplication of an interval number by a scalar can be defined by

$$\begin{aligned} kA &= [ka_L, ka_R] \text{ if } k \geq 0 \\ &= [ka_R, ka_L] \text{ if } k \leq 0 \end{aligned} \quad (13.17)$$

$$\text{or } kA = k \langle a_c, a_w \rangle = \langle ka_c, |k|a_w \rangle \quad (13.18)$$

### 13.10 Fuzzy Number

A fuzzy number is a special case of a fuzzy set. Different definitions and properties of fuzzy

numbers are encountered in the literature but they all agree on that fuzzy numbers represents the conception of a set of ,real numbers choose to a“ ,where ,a“ is the number of fuzzy field.A fuzzy number is a fuzzy set in the universe of discourse X i.e both convex and normal.

A Fuzzy number  $\tilde{A}$  is a fuzzy set defined on real line  $\mathfrak{R}$  whose membership function  $\mu_{\tilde{A}}(x)$  has the following characteristic with  $-\infty < a_1 < a_2 < a_3 < a_4 < \infty$

$$\mu_{\tilde{A}}(x) = \begin{cases} \mu_L(x) & \text{for } a_1 \leq x \leq a_2 \\ 1 & \text{for } a_2 \leq x \leq a_3 \\ \mu_R(x) & \text{for } a_3 \leq x \leq a_4 \\ 0 & \text{for otherwise} \end{cases} \quad (13.19)$$

where  $\mu_L(x) : [a_1, a_2] \rightarrow [0, 1]$  is continuous and strictly increasing;  $\mu_R : [a_3, a_4] \rightarrow [0, 1]$  is continuous and strictly decreasing. The general shape of fuzzy number following the above definition is shown below.

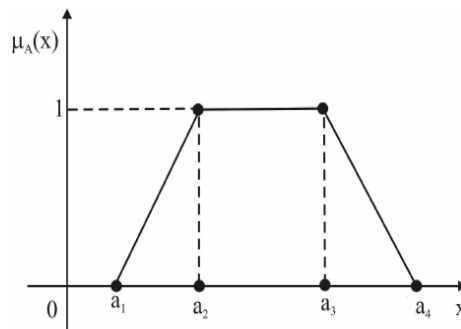

**Fig.-13.2 Fuzzy Number**

**Fig.-13.2 Triangular Fuzzy number(TFN)**

Let  $F(\mathfrak{R})$  be a set of all triangular fuzzy number in real line  $\mathfrak{R}$  . A triangular fuzzy number  $\tilde{A} \in F(\mathfrak{R})$  is fuzzy number with membership function  $\mu_{\tilde{A}} : \mathfrak{R} \rightarrow [0, 1]$  parameterized by a triplet  $(a_1, a_2, a_3)_{TFN}$  and defined by

$$\mu_{\tilde{A}}(x) = \begin{cases} \left( \frac{x - a_1}{a_2 - a_1} \right) & \text{for } a_1 \leq x \leq a_2 \\ 1 & \text{for } x = a_2 \\ \left( \frac{a_3 - x}{a_3 - a_2} \right) & \text{for } a_2 \leq x \leq a_3 \\ 0 & \text{otherwise} \end{cases} \quad (13.20)$$

where  $a_1$  and  $a_3$  denote the lower and upper limits of support of a fuzzy number  $\tilde{A}$

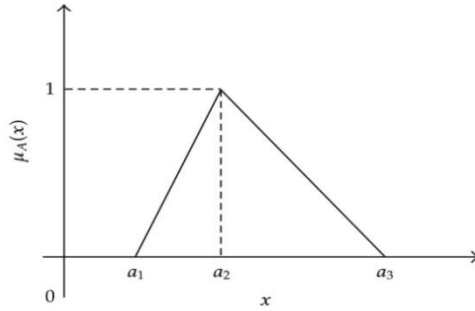

**Fig.-13.3 Triangular Fuzzy Number**

### 2.10.1 Trapezoidal Fuzzy Number(TrFN)

Let  $F(\mathfrak{R})$  be a set of all trapezoidal fuzzy number in real line  $\mathfrak{R}$ . A trapezoidal fuzzy number  $\tilde{A} \in F(\mathfrak{R})$  is fuzzy number with membership function  $\mu_{\tilde{A}} : \mathfrak{R} \rightarrow [0,1]$  parameterized by a quadruple  $(a_1, a_2, a_3, a_4)_{TrFN}$  and defined by

$$\mu_{\tilde{A}}(x) = \begin{cases} \left( \frac{x-a_1}{a_2-a_1} \right) & \text{for } a_1 \leq x \leq a_2 \\ 1 & \text{for } a_2 \leq x \leq a_3 \\ \left( \frac{a_4-x}{a_4-a_3} \right) & \text{for } a_3 \leq x \leq a_4 \\ 0 & \text{otherwise} \end{cases} \quad (13.21)$$

where  $a_1$  and  $a_4$  denote the lower and upper limits of support of a fuzzy number  $\tilde{A}$

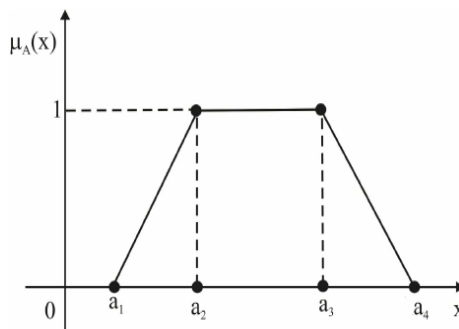

**Fig.-13.4 Trapezoidal Fuzzy Number**

### 13.11 $\alpha$ – Cut of Fuzzy Number

The  $\alpha$  –level of a fuzzy number  $\tilde{A}$  is defined as a crisp set

$$A_\alpha = \{x : \mu_{\tilde{A}}(x) \geq \alpha, x \in X, \alpha \in [0,1]\} \quad (13.22)$$

$A_\alpha$  is nonempty bounded closed interval contained in  $X$  and it can be denoted by

$$A_\alpha = [A_L(\alpha), A_R(\alpha)], \quad (13.23)$$

$A_L(\alpha)$  and  $A_R(\alpha)$  are the lower and upper bound of the closed interval.

### 13.12 Generalized Fuzzy Number (GFN)

Generalized fuzzy number can be defined as  $\tilde{A}$  as  $\tilde{A} = (a, b, c, d; w)$  where  $0 < w \leq 1$  and  $a, b, c, d$  are real numbers. The generalized fuzzy numbers  $\tilde{A}$  is a fuzzy subset of real line  $\mathfrak{R}$  whose membership function  $\mu_{\tilde{A}}(x)$  satisfies the following conditions

- 1)  $\mu_{\tilde{A}}(x)$  is continuous mapping from  $\mathfrak{R}$  to the closed interval  $[0, 1]$
- 2)  $\mu_{\tilde{A}}(x) = 0$  where  $-\infty < x \leq a$ ;
- 3)  $\mu_{\tilde{A}}(x)$  is strictly increasing with constant rate on  $[a, b]$
- 4)  $\mu_{\tilde{A}}(x) = w$  where  $b \leq x \leq c$
- 5)  $\mu_{\tilde{A}}(x)$  is strictly decreasing with constant rate on  $[c, d]$ ;
- 6)  $\mu_{\tilde{A}}(x) = 0$  where  $d \leq x \leq \infty$

Note:  $\tilde{A}$  is a convex fuzzy set and it is non normalized fuzzy number till  $w \neq 1$ . It will be normalized for  $w = 1$

i) If  $a = b = c = d$  and  $w = 1$ , then  $\tilde{A}$  is called a real number  $a$ .

Here  $\tilde{A} = (x, \mu_{\tilde{A}}(x))$  with membership function  $\mu_{\tilde{A}}(x) = \begin{cases} 1 & \text{if } x = a \\ 0 & \text{if } x \neq a \end{cases}$

ii) If  $a = b$  and  $c = d$ , then  $\tilde{A}$  is called a crisp interval  $[a, b]$ .

Here  $\tilde{A} = (x, \mu_{\tilde{A}}(x))$  with membership function  $\mu_{\tilde{A}}(x) = \begin{cases} 1 & \text{if } a \leq x \leq d \\ 0 & \text{if otherwise} \end{cases}$

iii) If  $b = c$  then  $\tilde{A}$  is called Generalized Triangular Fuzzy Number (GTFN) as  $(a, b, d; w)$

iv) If  $b = c, w = 1$  then  $\tilde{A}$  is called Triangular Fuzzy Number (TFN) as  $\tilde{A} = (a, b, d)$

Here  $\tilde{A} = (x, \mu_{\tilde{A}}(x))$  with membership function  $\mu_{\tilde{A}}(x) = \begin{cases} w \left( \frac{x-a}{b-a} \right) & \text{for } a \leq x \leq b \\ w \left( \frac{d-x}{d-b} \right) & \text{for } b \leq x \leq d \\ 0 & \text{otherwise} \end{cases}$

- v) If  $b \neq c$  then  $\tilde{A}$  is called Generalized Trapezoidal Fuzzy Number (GTrFN) and denoted by  $\tilde{A} = (a, b, c, d; w)$
- vi) If  $b \neq c, w = 1$  then  $\tilde{A}$  is called Trapezoidal Fuzzy Number (TrFN) as  $\tilde{A} = (a, b, c, d)$

Here  $\tilde{A} = (x, \mu_{\tilde{A}}(x))$  with membership function

$$\mu_{\tilde{A}}(x) = \begin{cases} w \left( \frac{x-a}{b-a} \right) & \text{for } a \leq x \leq b \\ w & \text{for } b \leq x \leq c \\ w \left( \frac{d-x}{d-c} \right) & \text{for } c \leq x \leq d \\ 0 & \text{otherwise} \end{cases} \quad (13.24)$$

Traditional fuzzy arithmetic operations can deal with only normalized fuzzy numbers and the type of membership function of fuzzy number are not changeable after arithmetic operations. Thus Chen [31] proposed the function principle by which these fuzzy arithmetic operations on fuzzy numbers does not only change the type of membership function after arithmetic operation, but they can also reduce the troublesomeness and tediousness of arithmetical operations. Thus in this chapter, we have introduced Chen's [31] fuzzy number arithmetical operators to deal with the fuzzy number arithmetical operation of generalized fuzzy numbers. The difference between the arithmetic operations on generalized fuzzy numbers and the traditional fuzzy numbers is that the later can deal with only normalized fuzzy number.

### 13.13 Nearest Interval Approximation of Fuzzy Number

Here we want to approximate an fuzzy number  $\tilde{A} = (a_1, a_2, a_3; w)$  by a crisp model.

Let  $\tilde{A}$  and  $\tilde{B}$  be two fuzzy number with  $\alpha$ -cuts  $[A_L(\alpha), A_U(\alpha)]$  and  $[B_L(\alpha), B_U(\alpha)]$  respectively. Then the distance between them can be measured according to Euclidean matrix as  $\tilde{d}_E^2 = \int_0^1 (A_L(\alpha) - B_L(\alpha))^2 d\alpha + \int_0^1 (A_U(\alpha) - B_U(\alpha))^2 d\alpha$  (13.25)

Now we find a closed interval  $\tilde{C}_{d_E}(\tilde{A}) = [C_L, C_U]$  which is nearest to  $\tilde{A}$  with respect to the matrix  $\tilde{d}_E$ . Again it is obvious that each real interval can also be considered as an fuzzy

number with constant  $\alpha$ -cut  $(\tilde{C}_{d_E}(\tilde{A}))\alpha = [C_L, C_U]$  for all  $\alpha \in [0, 1]$ . Now we have to

$$\text{minimize } \tilde{d}_E^2(\tilde{A}, \tilde{C}_{d_E}(\tilde{A})) = \int_0^1 (A_L(\alpha) - C_L)^2 d\alpha + \int_0^1 (A_U(\alpha) - C_U)^2 d\alpha \quad (13.26)$$

with respect to  $C_L$  and  $C_U$ . In order to minimize  $\tilde{d}_E(\tilde{A}, \tilde{C}_{d_E}(\tilde{A}))$  it is sufficient to minimize

the functions  $D(C_L, C_U) (= \tilde{d}_E^2(\tilde{A}, \tilde{C}_{d_E}(\tilde{A})))$ . The first partial derivatives are

$$\frac{\partial D(C_L, C_U)}{\partial C_L} = -2 \int_0^1 A_L(\alpha) d\alpha + 2C_L \quad (13.27)$$

$$\frac{\partial D(C_L, C_U)}{\partial C_U} = -2 \int_0^1 A_U(\alpha) d\alpha + 2C_U \quad (13.28)$$

And then we solve the system

$$\frac{\partial D(C_L, C_U)}{\partial C_L} = 0, \quad (13.29)$$

$$\frac{\partial D(C_L, C_U)}{\partial C_U} = 0 \quad (13.30)$$

The solution is

$$C_L = \int_0^1 A_L(\alpha) d\alpha; \quad (13.31)$$

$$C_U = \int_0^1 A_U(\alpha) d\alpha \quad (13.32)$$

Since

$$\det \begin{pmatrix} \frac{\partial^2 D(C_L, C_U)}{\partial C_L^2} & \frac{\partial^2 D(C_L, C_U)}{\partial C_L \partial C_U} \\ \frac{\partial^2 D(C_L, C_U)}{\partial C_L \partial C_U} & \frac{\partial^2 D(C_L, C_U)}{\partial C_U^2} \end{pmatrix} = \begin{pmatrix} 2 & 0 \\ 0 & 2 \end{pmatrix} = 4 > 0 \quad (13.33)$$

then  $C_L, C_U$  mentioned above minimize  $D(C_L, C_U)$ . The nearest interval of the intuitionistic

fuzzy number  $\tilde{A}$  with respect to the matrix  $\tilde{d}_E$  is

$$\tilde{C}_{d_E}(\tilde{A}) = \left[ \int_0^1 A_L(\alpha) d\alpha, \int_0^1 A_U(\alpha) d\alpha \right] = \left[ \frac{(2w-1)a_1 + a_2}{2w}, \frac{(2w-1)a_3 + a_2}{2w} \right] \quad (13.34)$$

### 13.14 Intuitionistic Fuzzy Set



Fuzzy set theory was first introduced by L.A.Zadeh [134] in 1965. Let  $X$  be the universe of discourse defined by  $X = \{x_1, x_2, \dots, x_n\}$ . The grade of membership of an element  $x_i \in X$  in a fuzzy set is represented by real value in  $[0, 1]$ . It does indicate the evidence of  $x_i \in X$  but does not indicate the evidence against  $x_i \in X$ . Atanassov [1] presented the concept of IFS. An IFS  $\tilde{A}^i$  in  $X$  is characterized by a membership function  $\mu_{\tilde{A}^i}(x)$  and a nonmembership function  $\nu_{\tilde{A}^i}(x)$ . Here  $\mu_{\tilde{A}^i}(x)$  and  $\nu_{\tilde{A}^i}(x)$  are associated with each point in  $X$ , a real number in  $[0, 1]$  with the values of  $\mu_{\tilde{A}^i}(x)$  and  $\nu_{\tilde{A}^i}(x)$  at  $X$  representing the grade of membership and non-membership of  $x$  in  $\tilde{A}^i$ . When  $\tilde{A}^i$  is an ordinary (crisp) set its membership function (non-membership functions) can only take two values zero and one. An IFS becomes a fuzzy set  $\tilde{A}$  when  $\nu_{\tilde{A}^i}(x) = 0$  but  $\mu_{\tilde{A}^i}(x) \in [0, 1] \forall x \in \tilde{A}^i$ . Let a set  $X$  be fixed. An intuitionistic fuzzy set  $\tilde{A}^i$  in  $X$  is an object having the form

$$\tilde{A}^i = \{ \langle x, \mu_{\tilde{A}^i}(x), \nu_{\tilde{A}^i}(x) \rangle : x \in X \}$$

where  $\mu_{\tilde{A}^i}(x) : X \rightarrow [0, 1]$  and  $\nu_{\tilde{A}^i}(x) : X \rightarrow [0, 1]$  define the degree of membership and degree of nonmembership respectively of the element  $x \in X$  to the set  $\tilde{A}^i$ , which is a subset of  $X$ , for every element of  $x \in X$ ,  $0 \leq \mu_{\tilde{A}^i}(x) + \nu_{\tilde{A}^i}(x) \leq 1$ . (13.35)

### 13.15 $(\alpha, \beta)$ - Level Or $(\alpha, \beta)$ - Cuts

A set of  $(\alpha, \beta)$ -cut, generated by an IFS  $\tilde{A}^i$  where  $(\alpha, \beta) \in [0, 1]$  are fixed number such that  $\alpha + \beta \leq 1$  is defined as

$$A_{(\alpha, \beta)}^i = \left\{ \langle x, \mu_{\tilde{A}^i}(x), \nu_{\tilde{A}^i}(x) \rangle / x \in X \mid \mu_{\tilde{A}^i}(x) \geq \alpha, \nu_{\tilde{A}^i}(x) \leq \beta, \alpha, \beta \in [0, 1] \right\} \quad (13.36)$$

.We define  $(\alpha, \beta)$ -level or  $(\alpha, \beta)$ -cut, denoted by  $A_{(\alpha, \beta)}^i$ , as the crisp set of elements  $x$  which belong to  $\tilde{A}^i$  at least to the degree  $\alpha$  and which belong to  $\tilde{A}^i$  at most to the degree  $\beta$ .

### 13.16 Convex Intuitionistic Fuzzy Set

An intuitionistic fuzzy set

$$\tilde{A}^i = \{ \langle x, \mu_{\tilde{A}^i}(x), \nu_{\tilde{A}^i}(x) \rangle : x \in X \} \quad (13.37)$$

is convex intuitionistic fuzzy set if

$$\mu_{\tilde{A}^i}(\lambda x_1 + (1 - \lambda)x_2) \geq \max \{ \mu_{\tilde{A}^i}(x_1), \mu_{\tilde{A}^i}(x_2) \} \quad (13.38)$$

$$\text{and } \nu_{\tilde{A}^i}(\lambda x_1 + (1-\lambda)x_2) \geq \min\{\nu_{\tilde{A}^i}(x_1), \nu_{\tilde{A}^i}(x_2)\} \quad \forall x_1, x_2 \in X \text{ and } 0 \leq \lambda \leq 1. \quad (13.39)$$

### 13.17 Union Of Two Intuitionistic Fuzzy Sets

Let  $\tilde{A}^i = \{\langle x, \mu_{\tilde{A}^i}(x), \nu_{\tilde{A}^i}(x) \rangle : x \in X\}$  and  $\tilde{B}^i = \{\langle x, \mu_{\tilde{B}^i}(x), \nu_{\tilde{B}^i}(x) \rangle : x \in X\}$  be two intuitionistic fuzzy sets, then union of two intuitionistic fuzzy set will be defined by

$$\tilde{A}^i \cup \tilde{B}^i = \{\langle x, \max\{\mu_{\tilde{A}^i}(x), \mu_{\tilde{B}^i}(x)\}, \min\{\nu_{\tilde{A}^i}(x), \nu_{\tilde{B}^i}(x)\} \rangle : x \in X\} \quad (13.40)$$

### 13.18 Intersection of Two Intuitionistic Fuzzy Sets

Let  $\tilde{A}^i = \{\langle x, \mu_{\tilde{A}^i}(x), \nu_{\tilde{A}^i}(x) \rangle : x \in X\}$  and  $\tilde{B}^i = \{\langle x, \mu_{\tilde{B}^i}(x), \nu_{\tilde{B}^i}(x) \rangle : x \in X\}$  be two intuitionistic fuzzy sets, then intersection of two intuitionistic fuzzy sets will be defined by

$$\tilde{A}^i \cap \tilde{B}^i = \{\langle x, \min\{\mu_{\tilde{A}^i}(x), \mu_{\tilde{B}^i}(x)\}, \max\{\nu_{\tilde{A}^i}(x), \nu_{\tilde{B}^i}(x)\} \rangle : x \in X\} \quad (13.41)$$

### 13.19 Generalized Intuitionistic Fuzzy Number(GIFN)

A generalised intuitionistic fuzzy number  $\tilde{A}^i$  can be defined with the following properties

- i) It is an intuitionistic fuzzy subset of real line.
- ii) It is normal i.e there exists  $x_0 \in R$  such that  $\mu_{\tilde{A}^i}(x_0) = w (\in R)$  and  $\nu_{\tilde{A}^i}(x_0) = \psi (\in R)$  for  $w + \psi \leq 1$ ;
- iii) It is a convex set for membership function  $\mu_{\tilde{A}^i}(x)$  i.e

$$\mu_{\tilde{A}^i}(\lambda x_1 + (1-\lambda)x_2) \geq \min(\mu_{\tilde{A}^i}(x_1), \mu_{\tilde{A}^i}(x_2)) \text{ for all } x_1, x_2 \in R, \lambda \in [0, w].$$

- iv) It is a concave set for non membership function  $\nu_{\tilde{A}^i}(x)$  i.e

$$\nu_{\tilde{A}^i}(\lambda x_1 + (1-\lambda)x_2) \geq \max(\nu_{\tilde{A}^i}(x_1), \nu_{\tilde{A}^i}(x_2)) \text{ for all } x_1, x_2 \in R, \lambda \in [\psi, 1].$$

- v)  $\mu_{\tilde{A}^i}$  is continuous mapping from  $R$  to the closed interval  $[0, w]$  and  $\nu_{\tilde{A}^i}$  is continuous mapping from  $R$  to the closed interval  $[\psi, 1]$  and for  $x_0 \in R$  the relation  $\mu_{\tilde{A}^i} + \nu_{\tilde{A}^i} \leq 1$  holds

### 13.20 Generalized Triangular Intuitionistic Fuzzy Number(GTIFN)

A generalized triangular intuitionistic fuzzy number  $\tilde{A}^i = ((a_1^\mu, a_2, a_3^\mu; w_a)(a_1^\nu, a_2, a_3^\nu; \tau_a))$  is a intuitionistic fuzzy number in  $\mathfrak{R}$  and can be defined with the following membership function and non-membership function as follows

$$\mu_{\tilde{A}^i} = \begin{cases} w_a \frac{x - a_1^\mu}{a_2 - a_1^\mu} & \text{for } a_1^\mu \leq x \leq a_2 \\ w_a & \text{for } x = a_2 \\ w_a \frac{a_3^\mu - x}{a_3^\mu - a_2} & \text{for } a_2 \leq x \leq a_3^\mu \\ 0 & \text{otherwise} \end{cases} \quad (13.42)$$

$$\nu_{\tilde{A}^i} = \begin{cases} \tau_a \frac{x - a_1^\nu}{a_2 - a_1^\nu} & \text{for } a_1^\nu \leq x \leq a_2 \\ \sigma_a & \text{for } x = a_2 \\ \tau_a \frac{x - a_2}{a_3^\nu - a_2} & \text{for } a_2 \leq x \leq a_3^\nu \\ 1 & \text{otherwise} \end{cases} \quad (13.43)$$

Where  $a_1^\nu \leq a_1^\mu \leq a_2 \leq a_3^\mu \leq a_3^\nu$ .

### 13.21 $\alpha$ -Level Set or $\alpha$ -Cut of Intuitionistic Fuzzy Number

Let  $\tilde{A}^i = ((a_1^\mu, a_2, a_3^\mu; w_a)(a_1^\nu, a_2, a_3^\nu; \tau_a))$  be a triangular intuitionistic fuzzy number then  $\alpha$ -cut of this intuitionistic fuzzy number is defined by the closed interval

$$\left[ \mu_{\tilde{A}_L^i}(\alpha), \mu_{\tilde{A}_U^i}(\alpha) \right], \alpha \in (0, 1] \text{ and } \left[ \nu_{\tilde{A}_L^i}(\alpha), \nu_{\tilde{A}_U^i}(\alpha) \right], \alpha \in [0, 1) \text{ where}$$

$$\mu_{\tilde{A}_L^i}(\alpha) = \inf \{ x \in R : \mu_{\tilde{A}_L^i}(x) \geq \alpha \} \quad (13.44)$$

$$\mu_{\tilde{A}_U^i}(\alpha) = \sup \{ x \in R : \mu_{\tilde{A}_U^i}(x) \geq \alpha \}, \quad (13.45)$$

$$\nu_{\tilde{A}_L^i}(\alpha) = \inf \{ x \in R : \nu_{\tilde{A}_L^i}(x) \leq \alpha \} \quad (13.46)$$

$$\nu_{\tilde{A}_U^i}(\alpha) = \sup \{ x \in R : \nu_{\tilde{A}_U^i}(x) \leq \alpha \}, \quad (13.47)$$

### 13.22 Arithmetic Operation of Triangular Intuitionistic Fuzzy Number (TIFN)

Let  $\tilde{A}^i = ((a_1^\mu, a_2, a_3^\mu; w_a)(a_1^\nu, a_2, a_3^\nu; \tau_a))$  and  $\tilde{B}^i = ((b_1^\mu, b_2, b_3^\mu; w_b)(b_1^\nu, b_2, b_3^\nu; \tau_b))$  be two triangular intuitionistic fuzzy number then the arithmetic operations on these numbers can be defined as follows

$$(i) \tilde{A}^i + \tilde{B}^i = ((a_1^\mu + b_1^\mu, a_2 + b_2, a_3^\mu + b_3^\mu; \min(w_a, w_b))(a_1^\nu + b_1^\nu, a_2 + b_2, a_3^\nu + b_3^\nu; \max(\tau_a, \tau_b)))$$

$$(ii) \tilde{A}^i - \tilde{B}^i = ((a_1^\mu - b_1^\mu, a_2 - b_2, a_3^\mu - b_3^\mu; \min(w_a, w_b))(a_1^\nu - b_1^\nu, a_2 - b_2, a_3^\nu - b_3^\nu; \max(\tau_a, \tau_b)))$$

$$\begin{aligned}
\text{(iii) } k\tilde{A}^i &= \begin{cases} \left( (ka_1^\mu, ka_2, ka_3^\mu; w_a)(ka_1^\nu, ka_2, ka_3^\nu; \tau_a) \right) & \text{for } k > 0 \\ \left( (ka_3^\mu, ka_2, ka_1^\mu; w_a)(ka_3^\nu, ka_2, ka_1^\nu; \tau_a) \right) & \text{for } k < 0 \end{cases} \\
\text{(iv) } \tilde{A}^i . \tilde{B}^i &= \begin{cases} \left( (a_1^\mu b_1^\mu, a_2 b_2, a_3^\mu b_3^\mu; \min(w_a, w_b))(a_1^\nu b_1^\nu, a_2 b_2, a_3^\nu b_3^\nu; \max(\tau_a, \tau_b)) \right) & \text{for } \tilde{A}^i > 0, \tilde{B}^i > 0 \\ \left( (a_1^\mu b_3^\mu, a_2 b_2, a_3^\mu b_1^\mu; \min(w_a, w_b))(a_1^\nu b_3^\nu, a_2 b_2, a_3^\nu b_1^\nu; \max(\tau_a, \tau_b)) \right) & \text{for } \tilde{A}^i > 0, \tilde{B}^i < 0 \\ \left( (a_3^\mu b_3^\mu, a_2 b_2, a_1^\mu b_1^\mu; \min(w_a, w_b))(a_3^\nu b_3^\nu, a_2 b_2, a_1^\nu b_1^\nu; \max(\tau_a, \tau_b)) \right) & \text{for } \tilde{A}^i < 0, \tilde{B}^i < 0 \end{cases} \\
\text{(v) } \tilde{A}^i / \tilde{B}^i &= \begin{cases} \left( (a_1^\mu / b_3^\mu, a_2 / b_2, a_3^\mu / b_1^\mu; \min(w_a, w_b))(a_1^\nu / b_3^\nu, a_2 / b_2, a_3^\nu / b_1^\nu; \max(\sigma_a, \sigma_b)) \right) & \text{for } \tilde{A}^i > 0, \tilde{B}^i > 0 \\ \left( (a_3^\mu / b_3^\mu, a_2 / b_2, a_1^\mu / b_1^\mu; \min(w_a, w_b))(a_3^\nu / b_3^\nu, a_2 / b_2, a_1^\nu / b_1^\nu; \max(\sigma_a, \sigma_b)) \right) & \text{for } \tilde{A}^i < 0, \tilde{B}^i > 0 \\ \left( (a_3^\mu / b_1^\mu, a_2 / b_2, a_1^\mu / b_3^\mu; \min(w_a, w_b))(a_3^\nu / b_1^\nu, a_2 / b_2, a_1^\nu / b_3^\nu; \max(\sigma_a, \sigma_b)) \right) & \text{for } \tilde{A}^i < 0, \tilde{B}^i < 0 \end{cases}
\end{aligned}$$

### 13.23 Nearest Interval Approximation for Intuitionistic Fuzzy Number

Here we want to approximate an intuitionistic fuzzy number  $\tilde{A}^i = ((a_1^\mu, a_2, a_3^\mu; w_a)(a_1^\nu, a_2, a_3^\nu; \tau_a))$  by a crisp model.

Let  $\tilde{A}^i$  and  $\tilde{B}^i$  be two intuitionistic fuzzy number. Then the distance between them can be measured according to Euclidean metric as

$$\begin{aligned}
\tilde{d}_E^2 &= \frac{1}{2} \int_0^1 (\mu_{A_L}(\alpha) - \mu_{B_L}(\alpha))^2 d\alpha + \frac{1}{2} \int_0^1 (\mu_{A_U}(\alpha) - \mu_{B_U}(\alpha))^2 d\alpha \\
&+ \frac{1}{2} \int_0^1 (\nu_{A_L}(\alpha) - \nu_{B_L}(\alpha))^2 d\alpha + \frac{1}{2} \int_0^1 (\nu_{A_U}(\alpha) - \nu_{B_U}(\alpha))^2 d\alpha \quad (13.48)
\end{aligned}$$

Now we find a closed interval  $\tilde{C}_{d_E}(\tilde{A}^i) = [C_L, C_U]$  which is nearest to  $\tilde{A}^i$  with respect to the metric  $\tilde{d}_E$ . Again it is obvious that each real interval can also be considered as an intuitionistic fuzzy number with constant  $\alpha$ -cut  $[C_L, C_U]$  for all  $\alpha \in [0, 1]$ . Now we have to minimize  $\tilde{d}_E(\tilde{A}^i, \tilde{C}_{d_E}(\tilde{A}^i))$  with respect to  $C_L$  and  $C_U$ , that is to minimize

$$\begin{aligned}
F_1(C_L, C_U) &= \int_0^1 (\mu_{A_L}(\alpha) - C_L)^2 d\alpha + \int_0^1 (\mu_{A_U}(\alpha) - C_U)^2 d\alpha \\
&+ \int_0^1 (\nu_{A_L}(\alpha) - C_L)^2 d\alpha + \int_0^1 (\nu_{A_U}(\alpha) - C_U)^2 d\alpha \quad (13.49)
\end{aligned}$$

With respect to  $C_L$  and  $C_U$ . We define partial derivatives

$$\frac{\partial F_1(C_L, C_U)}{\partial C_L} = -2 \int_0^1 (\mu_{A_L}(\alpha) + \nu_{A_L}(\alpha)) d\alpha + 4C_L \quad (13.50)$$

$$\frac{\partial F_1(C_L, C_U)}{\partial C_U} = -2 \int_0^1 (\mu_{A_U}(\alpha) + \nu_{A_U}(\alpha)) d\alpha + 4C_U \quad (13.51)$$

and then we solve the system

$$\frac{\partial F_1(C_L, C_U)}{\partial C_L} = 0, \quad (13.52)$$

$$\frac{\partial F_1(C_L, C_U)}{\partial C_U} = 0 \quad (13.53)$$

The solution is

$$C_L = \int_0^1 \frac{\mu_{A_L}(\alpha) + \nu_{A_L}(\alpha)}{2} d\alpha; \quad (13.54)$$

$$C_U = \int_0^1 \frac{\mu_{A_U}(\alpha) + \nu_{A_U}(\alpha)}{2} d\alpha \quad (13.55)$$

Since

$$\det \begin{pmatrix} \frac{\partial^2 F_1(C_L, C_U)}{\partial C_L^2} & \frac{\partial^2 F_1(C_L, C_U)}{\partial C_L \partial C_U} \\ \frac{\partial^2 F_1(C_L, C_U)}{\partial C_U \partial C_L} & \frac{\partial^2 F_1(C_L, C_U)}{\partial C_U^2} \end{pmatrix} = \begin{pmatrix} 4 & 0 \\ 0 & 4 \end{pmatrix} = 4 > 0 \quad (13.56)$$

then  $C_L, C_U$  mentioned above minimize  $F_1(C_L, C_U)$ . The nearest interval of the intuitionistic fuzzy number  $\tilde{A}^i$  with respect to the matrix  $\tilde{d}_E$  is

$$\begin{aligned} \tilde{C}_{d_E}(\tilde{A}^i) &= \left[ \int_0^1 \frac{\mu_{A_L}(\alpha) + \nu_{A_L}(\alpha)}{2} d\alpha, \int_0^1 \frac{\mu_{A_U}(\alpha) + \nu_{A_U}(\alpha)}{2} d\alpha \right] \\ &= \left[ \frac{a_1^\mu + a_2}{2} + \frac{a_2 - a_1^\mu}{4w} + \frac{a_2 - a_1^\nu}{4\tau}, \frac{a_2 + a_3^\mu}{2} + \frac{a_3^\mu - a_2}{4w} + \frac{a_3^\nu - a_2}{4\tau} \right] \end{aligned} \quad (13.57)$$

### 13.24 Parametric Interval Valued Function

If  $[m, n]$  be an interval with  $m, n > 0$  we can express an interval number by a function. The parametric interval-valued function for the interval  $[m, n]$  can be taken as

$$g(s) = m^{1-s} n^s \text{ for } s \in [0, 1] \quad (13.58)$$

which is strictly monotone continuous function and its inverse exists .Let  $\psi$  be the inverse of

$$g(s) \text{ then } s = \frac{\log \psi - \log m}{\log n - \log m}. \quad (13.59)$$

### 13.25 Ranking of Triangular Intuitionistic Fuzzy Number

A triangular intuitionistic fuzzy number  $\tilde{A}^i = ((a_1^\mu, a_2, a_3^\mu; w_a)(a_1^\nu, a_2, a_3^\nu; \tau_a))$  is completely defined by

$$L_\mu(x) = w_a \frac{x - a_1^\mu}{a_2 - a_1^\mu} \text{ for } a_1^\mu \leq x \leq a_2 \quad (13.60)$$

and

$$R_\mu(x) = w_a \frac{a_3^\mu - x}{a_3^\mu - a_2} \text{ for } a_2 \leq x \leq a_3^\mu; \quad (13.61)$$

$$L_\nu(x) = \tau_a \frac{a_2 - x}{a_2 - a_1^\nu} \text{ for } a_1^\nu \leq x \leq a_2 \quad (13.62)$$

and

$$R_\nu(x) = \tau_a \frac{x - a_2}{a_3^\nu - a_2} \text{ for } a_2 \leq x \leq a_3^\nu. \quad (13.63)$$

The inverse functions can be analytically express as

$$L_\mu^{-1}(h) = a_1^\mu + \frac{h}{w_a}(a_2 - a_1^\mu); \quad (13.64)$$

$$R_\mu^{-1}(h) = a_3^\mu - \frac{h}{w_a}(a_3^\mu - a_2); \quad (13.65)$$

$$L_\nu^{-1}(h) = a_2 + \frac{h}{\tau_a}(a_2 - a_1^\nu); \quad (13.66)$$

$$R_\nu^{-1}(h) = a_2 - \frac{h}{\tau_a}(a_3^\nu - a_2);$$

(13.67)

Now left integral value of membership and non-membership functions of  $\tilde{A}^i$  are

$$I_L(\tilde{A}^i) = \int_0^1 L_\mu^{-1}(h) = \frac{(2w_a - 1)a_1^\mu + a_2}{2w_a} \quad (13.68)$$

and

$$I_L(\tilde{A}^i) = \int_0^1 L_\nu^{-1}(h) = \frac{(2\tau_a - 1)a_1^\nu + a_2}{2\tau_a} \quad (13.69)$$

respectively

and right integral value of membership and non-membership functions are

$$I_R(\tilde{A}^i) = \int_0^1 L_\mu^{-1}(h) = \frac{(2w_a - 1)a_3^\mu + a_2}{2w_a} \quad (13.40)$$

and

$$I_R(\tilde{A}^i) = \int_0^1 L_\nu^{-1}(h) = \frac{(2\tau_a - 1)a_3^\nu + a_2}{2\tau_a} \quad (13.41)$$

respectively.

The total integral value of the membership functions is

$$I_T^\alpha(\tilde{A}^i) = \frac{(2w_a - 1)a_3^\mu + a_2}{2w_a} \alpha + (1 - \alpha) \frac{(2w_a - 1)a_1^\mu + a_2}{2w_a} = \frac{a_2 + (2w_a - 1)\{\alpha a_3^\mu + (1 - \alpha)a_1^\mu\}}{2w_a} \quad (13.42)$$

The total integral value of the non membership functions is

$$I_T^\beta(\tilde{A}^i) = \frac{(2\tau_a - 1)a_3^\nu + a_2}{2\tau_a} \beta + (1 - \beta) \frac{(2\tau_a - 1)a_1^\nu + a_2}{2\tau_a} = \frac{a_2 + (2\tau_a - 1)\{\beta a_3^\nu + (1 - \beta)a_1^\nu\}}{2\tau_a} \quad (13.43)$$

Now if  $\tilde{A}^i = ((a_1^\mu, a_2, a_3^\mu; w_a)(a_1^\nu, a_2, a_3^\nu; \tau_a))$  and  $\tilde{B}^i = ((b_1^\mu, b_2, b_3^\mu; w_b)(b_1^\nu, b_2, b_3^\nu; \tau_b))$  be two triangular intuitionistic fuzzy number then the following relations hold good

- i) If  $I_T^\alpha(\tilde{A}^i) < I_T^\alpha(\tilde{B}^i)$  and  $I_T^\beta(\tilde{A}^i) < I_T^\beta(\tilde{B}^i)$  for  $\alpha, \beta \in [0, 1]$  then  $\tilde{A}^i < \tilde{B}^i$
- ii) If  $I_T^\alpha(\tilde{A}^i) > I_T^\alpha(\tilde{B}^i)$  and  $I_T^\beta(\tilde{A}^i) > I_T^\beta(\tilde{B}^i)$  for  $\alpha, \beta \in [0, 1]$  then  $\tilde{A}^i > \tilde{B}^i$
- iii) If  $I_T^\alpha(\tilde{A}^i) = I_T^\alpha(\tilde{B}^i)$  and  $I_T^\beta(\tilde{A}^i) = I_T^\beta(\tilde{B}^i)$  for  $\alpha, \beta \in [0, 1]$  then  $\tilde{A}^i = \tilde{B}^i$

## APPENDIX-B

### 14.1 Geometric Programming(GP) Method

A Geometric Programming (GP) is a type of mathematical optimization problem characterized by objective and constraint functions that have a special form. GP is a methodology for solving algebraic non-linear optimization problems. Also linear programming is a subset of a GP .The theory of GP was initially developed about three decades ago and culminated in the publication of the seminal text in this area by Duffin, Peterson, and Zener [134]

The general constrained Primal GP problem can be stated as follows

**(P14.1)**

$$\text{Minimize } f_0(x) = \sum_{t=1}^{T_0} c_{0t} \prod_{j=1}^n x_j^{a_{0tj}} \quad (14.1)$$

subject to

$$f_i(x) = \sum_{t=1}^{T_m} c_{it} \prod_{j=1}^n x_j^{a_{itj}} \leq b_i; \quad i = 1, 2, 3, \dots, m \quad (14.2)$$

$$x_j > 0, \quad j = 1, 2, \dots, n. \quad (14.3)$$

Here  $c_{0t} > 0$  and  $a_{0tj}$  be any real number. The objective function contains  $T_0$  terms and inequality constraints contain  $T_i$  terms. Here the coefficient of each term is positive. So it is a constrained posynomial GP problem. Let  $T = T_0 + T_1 + \dots + T_i$  be the total number of terms in the primal programme. The degree of difficulty (DD) is defined as  $DD = \text{Total no. of terms} - (\text{Total no. of variables} - 1) = T - (n + 1)$ . The dual problem (with the objective function  $d(w)$ , where  $w \equiv \{w(w_{it}), \forall i = 0, 1, 2, \dots, m; t = 1, 2, \dots, T_i\}$  is the decision vector) of the GP problem (P14.1) for the general posynomial case is as follows

**(P14.2)**

$$\text{Maximize } d(w) = \prod_{t=1}^{T_0} \left( \frac{c_{0t}}{w_{0t}} \right)^{w_{0t}} \prod_{i=1}^m \prod_{t=1}^{T_i} \left( \frac{c_{it} \sum w_{it}}{b_i w_{it}} \right)^{w_{it}} \quad (14.4)$$

subject to

$$\sum_{t=1}^{T_0} w_{0t} = 1, \quad (\text{Normality condition}) \quad (14.5)$$



$$\sum_{i=0}^m \sum_{t=1}^{T_i} a_{ijt} w_{it} = 0 \quad \text{for } j = 1, 2, \dots, n. \quad (\text{Orthogonality conditions}) \quad (14.6)$$

$$w_{it} > 0 \quad \forall i = 0, 1, \dots, m; t = 1, 2, \dots, T_i. \quad (14.7)$$

For a primal problem with  $m$  variables,  $T_0 + T_1 + \dots + T_i$  terms and  $n$  constraints, the dual problem consists of  $T_0 + T_1 + \dots + T_i$  variables and  $m + 1$  constraints. The relation between these problems, the optimality has been shown to satisfy

$$c_{0t} \prod_{j=1}^n x_j^{a_{0jt}} = d^*(w^*) \times w_{0t}^* \quad t = 1, 2, 3, \dots, T_i \quad (14.8)$$

$$c_{it} \prod_{j=1}^n x_j^{a_{ijt}} = \frac{w_{it}^*}{\sum_{t=1}^{T_i} w_{it}^*} \quad i = 1, 2, 3, \dots, m; t = 1, 2, 3, \dots, T_i \quad (14.9)$$

Taking logarithms in (14.8) and (14.9) and putting  $t_j = \log x_j$  for  $j = 1, 2, \dots, n$ . we shall get a system of linear equations of  $t_j$  ( $j = 1, 2, \dots, n$ ). We can easily find primal variables from the system of linear equations.

Case I: For  $T \geq n + 1$ , the dual programme presents a system of linear equations for the dual variables where the number of linear equations is either less than or equal to the number of dual variables. A solution vector exists for the dual variable (Beightler and Philips [9]).

Case II: For  $T < n + 1$ , the dual programme presents a system of linear equations for the dual variables where the number of linear equation is greater than the number of dual variables. In this case, generally, no solution vector exists for the dual variables. However, one can get an approximate solution vector for this system using either the least squares or the linear programming method.

## 14.2 Posynomial Geometric Programming Problem

Let us consider the primal Geometric Problem as

**(P14.3)**

$$\text{Minimize } f_0(x) \quad (14.10)$$

Subject to

$$f_j(x) = \sum_{k=1}^{N_j} C_{jk} \prod_{i=1}^n x_i^{a_{jki}} \leq 1 \quad j = 1, 2, \dots, m \quad (14.11)$$

$$x_i \geq 0 \quad i = 1, 2, \dots, n \quad (14.12)$$

Where  $C_{jk} > 0$  and  $a_{jki}$  are all real.  $x = (x_1, x_2, \dots, x_n)^T$ .

The dual problem of (P14.3) can be written as

$$\text{Maximize } d(w) = \sum_{j=0}^m \prod_{k=1}^{N_j} \left( \frac{C_{jk} w_{j0}}{w_{jk}} \right)^{w_{jk}} \quad (14.13)$$

Subject to

$$\sum_{k=1}^{N_j} w_{0k} = 1 \quad (\text{Normality Condition}) \quad (14.14)$$

$$\sum_{j=0}^m \sum_{k=1}^{N_j} a_{jki} w_{jk} = 0 \quad (\text{Orthogonality Condition}) \quad (14.15)$$

$$w_{j0} = \sum_{k=1}^{N_j} w_{jk} \geq 0, \quad (14.16)$$

$$w_{jk} \geq 0, \quad (14.17)$$

$$i = 1, 2, \dots, n; k = 1, 2, \dots, N_j;$$

$$w_{00} = 1. \quad (14.18)$$

### 14.3 Signomial Geometric Programming Problem

Let us consider the primal Geometric Problem as

(P14.4)

$$\text{Minimize } f_0(x) \quad (14.19)$$

Subject to

$$f_j(x) = \sum_{k=1}^{N_j} \delta_{jk} C_{jk} \prod_{i=1}^n x_i^{a_{jki}} \leq \delta_j \quad j = 1, 2, \dots, m \quad (14.20)$$

$$x_i > 0 \quad i = 1, 2, \dots, n \quad (14.21)$$

Where  $\delta_{jk} = \pm 1, j = 0, 1, 2, \dots, m; k = 1, 2, \dots, N_j$  and  $\delta_j = \pm 1$   $a_{jki}$  are all real numbers.

$$x = (x_1, x_2, \dots, x_n)^T$$

The dual problem of (P14.4) can be written as

$$\text{Maximize } d(w) = \delta_0 \left[ \prod_{j=0}^m \prod_{k=1}^{N_j} \left( \frac{C_{jk} w_{j0}}{w_{jk}} \right)^{\delta_{jk} w_{jk}} \right]^{\delta_0} \quad (14.22)$$

Subject to

$$\sum_{k=1}^{N_j} \delta_{0k} w_{0k} = \delta_0 \quad (\text{Normality Condition}) \quad (14.23)$$

$$\sum_{j=0}^m \sum_{k=1}^{N_j} \delta_{jk} a_{jki} w_{jk} = 0 \quad (\text{Orthogonality Condition}) \quad (14.24)$$

Where  $\delta_{jk} = \pm 1, j = 0, 1, 2, \dots, m; k = 1, 2, \dots, N_j$  and  $\delta_j = \pm 1$   $a_{jki}$  are all real numbers.

$$x = (x_1, x_2, \dots, x_n)^T$$

$$w_{j0} = \delta_j \sum_{k=1}^{N_j} \delta_{jk} w_{jk} \geq 0, \quad (14.25)$$

$$\delta_{jk} \geq 0, \quad (14.26)$$

$$j = 1, 2, \dots, m; k = 1, 2, \dots, N_j;$$

$$w_{00} = 1. \quad (14.27)$$

#### 14.4 Fuzzy Geometric Programming(FGP)

A fuzzy geometric programming problem can be defined as

**(P14.5)**

$$\text{Minimize } f_0(x) \quad (14.28)$$

Subject to

$$f_j(x) \lesssim b_j \quad j = 1, 2, \dots, m \quad (14.29)$$

$$x_i \geq 0 \quad i = 1, 2, \dots, n$$

Here the symbol "*Minimize*" denotes a relaxed version of "Minimize". Similarly the symbol " $\lesssim$ " denotes a fuzzy version of " $\leq$ ". These fuzzy requirements may be quantified by taking membership function  $\mu_j(f_j(x)), j = 0, 1, 2, \dots, m$  from the decision maker for all functions  $f_j(x), j = 0, 1, 2, \dots, m$  by taking account of the rate of increased membership functions. It is in general strictly monotone decreasing linear or non-linear function with respect to  $f_j(x), j = 0, 1, 2, \dots, m$ . Here for simplicity linear membership functions are considered. The linear membership function can be represented by

$$\mu_j(f_j(x)) = \begin{cases} 1 & \text{if } f_j(x) \leq f_j^0 \\ \frac{f_j' - f_j(x)}{f_j' - f_j^0} & \text{if } f_j^0 \leq f_j(x) \leq f_j' \\ 0 & \text{if } f_j(x) \geq f_j' \end{cases} \quad (14.30)$$

$$j = 0, 1, 2, \dots, m$$

The problem (P14.5) reduces to the FGP when  $f_0(t)$  and  $f_j(x)$  are signomial and posignomial functions. Based on fuzzy decision making of Bellmann and Zadeh(1972), we may write

$$i) \mu_D(x^*) = \max\left(\min\left(\mu_j(f_j(x))\right)\right) \quad (\text{Max-Min Operator})(14.31)$$

Subject to

$$\mu_j(f_j(x)) = \begin{cases} 1 & \text{if } f_j(x) \leq f_j^0 \\ \frac{f_j' - f_j(x)}{f_j' - f_j^0} & \text{if } f_j^0 \leq f_j(x) \leq f_j' \\ 0 & \text{if } f_j(x) \geq f_j' \end{cases} \quad (14.32)$$

$$j = 0, 1, 2, \dots, m \quad x = (x_1, x_2, \dots, x_n)^T \quad x > 0$$

$$ii) \mu_D(x^*) = \max\left(\sum_{j=0}^m \lambda_j \mu_j(f_j(x))\right) \quad (\text{Max-Additive Operator})(14.33)$$

Subject to

$$\mu_j(f_j(x)) = \begin{cases} 1 & \text{if } f_j(x) \leq f_j^0 \\ \frac{f_j' - f_j(x)}{f_j' - f_j^0} & \text{if } f_j^0 \leq f_j(x) \leq f_j' \\ 0 & \text{if } f_j(x) \geq f_j' \end{cases} \quad (14.34)$$

$$j = 0, 1, 2, \dots, m \quad x = (x_1, x_2, \dots, x_n)^T \quad x > 0$$

$$iii) \mu_D(x^*) = \max\left(\prod_{j=0}^m \left(\mu_j(f_j(x))\right)^{\lambda_j}\right) \quad (\text{Max-Product Operator})(14.35)$$

Subject to

$$\mu_j(f_j(x)) = \begin{cases} 1 & \text{if } f_j(x) \leq f_j^0 \\ \frac{f_j' - f_j(x)}{f_j' - f_j^0} & \text{if } f_j^0 \leq f_j(x) \leq f_j' \\ 0 & \text{if } f_j(x) \geq f_j' \end{cases} \quad (14.36)$$

$$j = 0, 1, 2, \dots, m \quad x = (x_1, x_2, \dots, x_n)^T \quad x > 0$$

Here for  $j = 0, 1, 2, \dots, m$ ;  $\lambda_j$  are considered numerical weights of decision making unit. For normalized weight  $\sum_{j=0}^m \lambda_j = 1$ . For equal importance of objective and constraint goals,  $\lambda_j = 1$

And  $\lambda_j \in [0, 1]$ ,  $j = 0, 1, 2, \dots, m$ ;

### 14.5 Numerical example Of Fuzzy Geometric Programming

Let us consider a fuzzy geometric programming problem as

**(P14. 6)**

$$\text{Minimize } f_0(x_1, x_2) = 2x_1^{-2}x_2^{-3} \quad (\text{target value } 57.87 \text{ with tolerance } 2.91) \quad (14.37)$$

Subject to

$$f_1(x_1, x_2) = x_1^{-1}x_2^{-1} \leq 6.75 \quad (\text{with tolerance } 2.91) \quad (14.38)$$

$$f_2(x_1, x_2) = x_1 + x_2 \leq 1 \quad (14.39)$$

$$x_1, x_2 > 0$$

Here linear membership functions for fuzzy objectives and constraints goals are

$$\mu_0(f_0(x_1, x_2)) = \begin{cases} 1 & \text{if } 2x_1^{-2}x_2^{-3} \leq 57.87 \\ \frac{60.78 - 2x_1^{-2}x_2^{-3}}{2.91} & \text{if } 57.87 \leq 2x_1^{-2}x_2^{-3} \leq 60.78 \\ 0 & \text{if } 2x_1^{-2}x_2^{-3} \geq 60.78 \end{cases} \quad (14.40)$$

$$\mu_1(f_1(x_1, x_2)) = \begin{cases} 1 & \text{if } x_1^{-1}x_2^{-1} \leq 6.75 \\ \frac{6.94 - x_1^{-1}x_2^{-1}}{0.19} & \text{if } 6.75 \leq x_1^{-1}x_2^{-1} \leq 6.94 \\ 0 & \text{if } x_1^{-1}x_2^{-1} \geq 6.94 \end{cases} \quad (14.41)$$

Based on max-additive operator FGP (P14.6) reduces to

**(P14. 7)**

$$\text{Maximize } V_A(x_1, x_2) = \frac{6.94 - x_1^{-1}x_2^{-1}}{0.19} + \frac{60.78 - 2x_1^{-2}x_2^{-3}}{2.91} \quad (14.42)$$

Subject to

$$f_2(x_1, x_2) = x_1 + x_2 \leq 1 \quad (14.43)$$

$$x_1, x_2 > 0$$

Neglecting the constant term in the following model we have following crisp geometric programming problem as

**(P14. 8)**

$$\text{Maximize } V(x_1, x_2) = 5.263x_1^{-1}x_2^{-1} + 0.687x_1^{-2}x_2^{-3} \quad (14.44)$$

Subject to

$$f_2(x_1, x_2) = x_1 + x_2 \leq 1 \quad (14.45)$$

$$x_1, x_2 > 0 \quad (14.46)$$

Here  $DD=4-(2+1)=1$

The dual problem of this GP is

**(P14. 9)**

$$\text{Max } d(w) = \left(\frac{5.263}{w_{01}}\right)^{w_{01}} \left(\frac{0.687}{w_{02}}\right)^{w_{02}} \left(\frac{1}{w_{11}}\right)^{w_{11}} \left(\frac{1}{w_{12}}\right)^{w_{12}} (w_{11} + w_{12})^{(w_{11}+w_{12})} \quad (14.47)$$

Such that

$$w_{01} + w_{02} = 1 \quad (14.48)$$

$$-w_{01} - 2w_{02} + w_{11} = 0 \quad (14.49)$$

$$-2w_{01} - 3w_{02} + w_{12} = 0 \quad (14.50)$$

$$\text{So } w_{02} = 1 - w_{01}; w_{11} = 2 - w_{01}; w_{12} = 3 - w_{01}; \quad (14.51)$$

$$\text{Maximize } d(w_{01}) = \left(\frac{5.263}{w_{01}}\right)^{w_{01}} \left(\frac{0.687}{1-w_{01}}\right)^{(1-w_{01})} \left(\frac{1}{2-w_{01}}\right)^{(2-w_{01})} \left(\frac{1}{3-w_{01}}\right)^{(3-w_{01})} (5-2w_{01})^{(5-2w_{01})} \quad (14.52)$$

Subject to

$$0 < w_{01} < 1 \quad (14.53)$$

$$\text{For optimality, } \frac{d(d(w_{01}))}{dw_{01}} = 0 \quad (14.54)$$

$$5.263(1-w_{01})(2-w_{01})(3-w_{01}) = 0.687w_{01}(5-2w_{01})^2 \quad (14.55)$$

$$w_{01}^* = 0.7035507, w_{02}^* = 0.2964493, w_{11}^* = 1.296449, w_{12}^* = 2.296449, \quad (14.56)$$

$$x_1^* = 0.360836, x_2^* = 0.6391634, \quad (14.57)$$

$$f_0^*(x_1^*, x_2^*) = 58.82652, f_1^*(x_1^*, x_2^*) = 6.783684,$$

## 14.6 Intuitionistic Fuzzy Geometric Programming

Consider an Intuitionistic Fuzzy Geometric Programming Problem as

**(P14.10)**

$$\text{Min } f_0^i(x) \quad (14.58)$$

Subject to

$$f_j(x) \lesssim^i b_j \quad j=1,2,\dots,m \quad (14.59)$$

$$x > 0$$

(14.60)

Here the symbol " $\lesssim^i$ " denotes the intuitionistic fuzzy version of " $\leq$ ". Now for intuitionistic fuzzy geometric programming linear membership and non-membership can be represented as follows

$$\mu_j(f_j(x)) = \begin{cases} 1 & \text{if } f_j(x) \leq f_j^0 \\ \frac{f_j^i - f_j(x)}{f_j^i - f_j^0} & \text{if } f_j^0 \leq f_j(x) \leq f_j^i \\ 0 & \text{if } f_j(x) \geq f_j^i \end{cases} \quad (14.61)$$

$$j = 0, 1, 2, \dots, m$$

$$\nu_j(f_j(x)) = \begin{cases} 1 & \text{if } f_j(x) \leq (f_j^i - f_j^0) \\ \frac{f_j(x) - (f_j^i - f_j^0)}{f_j^i} & \text{if } (f_j^i - f_j^0) \leq f_j(x) \leq f_j^i \\ 0 & \text{if } f_j(x) \geq f_j^i \end{cases} \quad (14.62)$$

$$j = 0, 1, 2, \dots, m$$

Now an Intuitionistic Fuzzy Geometric programming problem(P14.10) with membership and non-membership function can be written as

**(P14.11)**

$$\text{Maximize } \mu_j(f_j(x)) \quad (14.63)$$

$$\text{Minimize } \nu_j(f_j(x)) \quad (14.64)$$

$$j = 0, 1, 2, \dots, m$$

Considering equal importance of all membership and non-membership functions and using weighted sum method the above optimization problem reduces to

**(P14.12)**

$$\text{Maximize } V_A = \sum_{j=0}^m \{ \mu_j(f_j(x)) - \nu_j(f_j(x)) \} \quad (14.65)$$

Subject to

$$x \geq 0 \quad (14.66)$$

The above problem is equivalent to

$$\text{Minimize } V_{A1} = \sum_{j=0}^m \left\{ \left( \frac{1}{f_j' - f_j^0} + \frac{1}{f_j''} \right) f_j(x) - \left( \frac{f_j' - f_j''}{f_j''} + \frac{f_j'}{f_j' - f_j^0} \right) \right\} \quad (14.67)$$

Subject to

$$f_j(x) = \sum_{k=1}^{N_j} C_{jk} \prod_{i=1}^n x_i^{a_{jki}} \leq 1 \quad j = 1, 2, \dots, m \quad (14.68)$$

$$x_i \geq 0 \quad i = 1, 2, \dots, n \quad (14.69)$$

Where  $C_{jk} > 0$  and  $a_{jki}$  are all real.  $x = (x_1, x_2, \dots, x_n)^T$ .

The posynomial Geometric Programming problem can be solved by usual geometric programming technique.

### Numerical example

Consider an Intuitionistic Fuzzy Nonlinear Programming Problem as

**(P14.13)**



$$\text{Minimize } f_0(x_1, x_2) = 2x_1^{-2}x_2^{-3} \text{ (target value 57.87 with tolerance 2.91)} \quad (14.70)$$

Subject to

$$f_1(x_1, x_2) = x_1^{-1}x_2^{-2} \leq 6.75 \text{ (with tolerance 2.91)} \quad (14.71)$$

$$f_2(x_1, x_2) = x_1 + x_2 \leq 1 \quad (14.72)$$

$$x_1, x_2 > 0$$

Here linear membership and non-membership functions for fuzzy objectives and constraints goals are

$$\mu_0(f_0(x_1, x_2)) = \begin{cases} 1 & \text{if } 2x_1^{-2}x_2^{-3} \leq 57.87 \\ \frac{60.78 - 2x_1^{-2}x_2^{-3}}{2.91} & \text{if } 57.87 \leq 2x_1^{-2}x_2^{-3} \leq 60.78 \\ 0 & \text{if } 2x_1^{-2}x_2^{-3} \geq 60.78 \end{cases} \quad (14.73)$$

$$\mu_1(f_1(x_1, x_2)) = \begin{cases} 1 & \text{if } x_1^{-1}x_2^{-2} \leq 6.75 \\ \frac{6.94 - x_1^{-1}x_2^{-2}}{0.19} & \text{if } 6.75 \leq x_1^{-1}x_2^{-2} \leq 6.94 \\ 0 & \text{if } x_1^{-1}x_2^{-2} \geq 6.94 \end{cases} \quad (14.74)$$

$$\nu_0(f_0(x_1, x_2)) = \begin{cases} 1 & \text{if } 2x_1^{-2}x_2^{-3} \leq 59.03 \\ \frac{2x_1^{-2}x_2^{-3} - 59.03}{1.75} & \text{if } 59.03 \leq 2x_1^{-2}x_2^{-3} \leq 60.78 \\ 0 & \text{if } 2x_1^{-2}x_2^{-3} \geq 60.78 \end{cases} \quad (14.75)$$

$$\nu_1(f_1(x_1, x_2)) = \begin{cases} 1 & \text{if } x_1^{-1}x_2^{-2} \leq 6.83 \\ \frac{x_1^{-1}x_2^{-2} - 6.83}{0.11} & \text{if } 6.83 \leq x_1^{-1}x_2^{-2} \leq 6.94 \\ 0 & \text{if } x_1^{-1}x_2^{-2} \geq 6.94 \end{cases} \quad (14.76)$$

Based on max-additive operator FGP (14.13) reduces to

**(P14.14)**

$$\text{Maximize } V_A(x_1, x_2) = \left(\frac{1}{0.19} + \frac{1}{0.11}\right)x_1^{-1}x_2^{-2} + \left(\frac{1}{2.91} + \frac{1}{1.75}\right)2x_1^{-2}x_2^{-3} \quad (14.77)$$

Subject to

$$f_2(x_1, x_2) = x_1 + x_2 \leq 1 \quad (14.78)$$

$$x_1, x_2 > 0$$

Neglecting the constant term in the following model we have following crisp geometric programming problem as

**(P14.15)**

$$\text{Maximize } V(x_1, x_2) = 14.35x_1^{-1}x_2^{-1} + 1.828x_1^{-2}x_2^{-3} \quad (14.79)$$

Subject to

$$f_2(x_1, x_2) = x_1 + x_2 \leq 1 \quad (14.80)$$

$$x_1, x_2 > 0 \quad (14.81)$$

$$\text{Here DD} = 4 - (2+1) = 1$$

The dual problem of this GP is

$$\text{Max } d(w) = \left(\frac{14.354}{w_{01}}\right)^{w_{01}} \left(\frac{1.828}{w_{02}}\right)^{w_{02}} \left(\frac{1}{w_{11}}\right)^{w_{11}} \left(\frac{1}{w_{12}}\right)^{w_{12}} (w_{11} + w_{12})^{(w_{11} + w_{12})} \quad (14.82)$$

Such that

$$w_{01} + w_{02} = 1 \quad (14.83)$$

$$-w_{01} - 2w_{02} + w_{11} = 0 \quad (14.84)$$

$$-2w_{01} - 3w_{02} + w_{12} = 0 \quad (14.85)$$

$$\text{So } w_{02} = 1 - w_{01}; w_{11} = 2 - w_{01}; w_{12} = 3 - w_{01}; \quad (14.86)$$

$$\text{Maximize } d(w_{01}) = \left(\frac{14.354}{w_{01}}\right)^{w_{01}} \left(\frac{1.828}{1-w_{01}}\right)^{(1-w_{01})} \left(\frac{1}{2-w_{01}}\right)^{(2-w_{01})} \left(\frac{1}{3-w_{01}}\right)^{(3-w_{01})} (5-2w_{01})^{(5-2w_{01})} \quad (14.87)$$

Subject to

$$0 < w_{01} < 1 \quad (14.88)$$

$$\text{For optimality, } \frac{d(d(w_{01}))}{dw_{01}} = 0 \quad (14.89)$$

$$14.354(1-w_{01})(2-w_{01})(3-w_{01}) = 1.828w_{01}(5-2w_{01})^2 \quad (14.90)$$

$$w_{01}^* = 0.6454384, w_{02}^* = 0.3545616, w_{11}^* = 1.3545616, w_{12}^* = 2.3545616, \quad (14.91)$$

$$x_1^* = 0.365197, x_2^* = 0.63348027, \tag{14.92}$$

$$f_0^*(x_1^*, x_2^*) = 58.62182, f_1^*(x_1^*, x_2^*) = 6.795091,$$

### 14.7 Fuzzy Decision Making

In this real world ,most of the decision making problems take place in a fuzzy environment. The objective goal, constraints and consequences of possible actions are not known precisely. Under this observation, Bellman et al. [10] introduced three basic concepts. They are fuzzy objective goal, fuzzy constraint and fuzzy decision based on fuzzy goal and constraint. We introduce the conceptual framework for decision making in a fuzzy environment .Let  $X$  be a given set of possible alternatives which contains the solution of a decision making problem in fuzzy environment. The problem based on fuzzy decision making may be considered as follows

Optimize fuzzy goal  $\tilde{G}$   
 Subject to constraint  $\tilde{C}$

A Fuzzy goal  $\tilde{G} = \{(x, \mu_{\tilde{G}}(x)) | x \in X\}$  and a fuzzy constraint  $\tilde{C} = \{(x, \mu_{\tilde{C}}(x)) | x \in X\}$  is a fuzzy set characterised by its membership function  $\mu_{\tilde{G}}(x): X \rightarrow [0,1]$  and  $\mu_{\tilde{C}}(x): X \rightarrow [0,1]$  respectively. Both the fuzzy goal and fuzzy constraints are desired to be satisfied simultaneously, So Bellman et al. [10] defined fuzzy decision through fuzzy goal and fuzzy constraint.

### 14.8 Additive Fuzzy Decision

Fuzzy decision based on additive operator is a fuzzy set

$$\tilde{D}_a = \{(x, \mu_{\tilde{D}_a}(x)) | x \in X\} \tag{14.93}$$

such that

$$\tilde{D}_a = \mu_{\tilde{G}}(x) + \mu_{\tilde{C}}(x) \text{ for all } x \in X. \tag{14.94}$$

### 14.9 Intuitionistic Fuzzy Optimization(IFO) Technique to solve Minimization Type Single Objective Non-linear Programming (SONLP) Problem

Let us consider a SONLP problem as

**(P14.16)**

$$\text{Minimize } f(x) \quad (14.95)$$

$$g_j(x) \leq b_j \quad j = 1, 2, \dots, m \quad (14.96)$$

$$x \geq 0 \quad (14.97)$$

Usually constraints goals are considered as fixed quantity .But in real life problem,the constraint goal cannot be always exact. So we can consider the constraint goal for less than type constraints at least  $b_j$  and it may possible to extend to  $b_j + b_j^0$ . This fact seems to take the constraint goal as a IFS and which will be more realistic descriptions than others. Then the NLP becomes IFO problem with intuitionistic resources, which can be described as follows

**(P14.17)**

$$\text{Minimize } f(x) \quad (14.98)$$

$$g_j(x) \leq \tilde{b}_j^i \quad j = 1, 2, \dots, m \quad (14.99)$$

$$x \geq 0 \quad (14.100)$$

To solve the IFO (P14.16), following warner's [118] and Angelov [3] we are presenting a solution procedure for Single Objective Intuitionistic Fuzzy Optimization (SOIFO) problem as follows

**Step-1:** Following Werner's approach solve the single objective non-linear programming problem without tolerance in constraints (i.e  $g_j(x) \leq b_j$ ),with tolerance of acceptance in constraints (i.e  $g_j(x) \leq b_j + b_j^0$ ) by appropriate non-linear programming technique

Here they are

**(P14.18)**

**Sub-problem-1**

$$\text{Minimize } f(x) \quad (14.101)$$

$$g_j(x) \leq b_j \quad j = 1, 2, \dots, m \quad (14.102)$$

$$x \geq 0 \quad (14.103)$$

**(P14.19)**

**Sub-problem-2**

$$\text{Minimize } f(x) \quad (14.104)$$

$$g_j(x) \leq b_j + b_j^0, \quad j = 1, 2, \dots, m \quad (14.105)$$

$$x \geq 0 \quad (14.106)$$

we may get optimal solutions  $x^* = x^1, f(x^*) = f(x^1)$  and  $x^* = x^2, f(x^*) = f(x^2)$  for sub-problem 1 and 2 respectively.

**Step-2:** From the result of step 1 we now find the lower bound and upper bound of objective functions. If  $U_{f(x)}^\mu, U_{f(x)}^\nu$  be the upper bounds of membership and non-membership functions for the objective respectively and  $L_{f(x)}^\mu, L_{f(x)}^\nu$  be the lower bound of membership and non-membership functions of objective respectively then

$$U_{f(x)}^\mu = \max \{f(x^1), f(x^2)\} \quad (14.107)$$

$$L_{f(x)}^\mu = \min \{f(x^1), f(x^2)\}, \quad (14.108)$$

$$U_{f(x)}^\nu = U_{f(x)}^\mu, L_{f(x)}^\nu = L_{f(x)}^\mu + \varepsilon_{f(x)} \text{ where } 0 < \varepsilon_{f(x)} < (U_{f(x)}^\mu - L_{f(x)}^\mu) \quad (14.109)$$

**Step-3:** In this step we calculate linear membership for membership and non-membership functions of objective as follows

$$\mu_{f(x)}(f(x)) = \begin{cases} 1 & \text{if } f(x) \leq L_{f(x)}^\mu \\ \left( \frac{U_{f(x)}^\mu - f(x)}{U_{f(x)}^\mu - L_{f(x)}^\mu} \right) & \text{if } L_{f(x)}^\mu \leq f(x) \leq U_{f(x)}^\mu \\ 0 & \text{if } f(x) \geq U_{f(x)}^\mu \end{cases} \quad (14.110)$$

$$\nu_{f(x)}(f(x)) = \begin{cases} 0 & \text{if } f(x) \leq L_{f(x)}^\nu \\ \frac{f(x) - L_{f(x)}^\nu}{U_{f(x)}^\nu - L_{f(x)}^\nu} & \text{if } L_{f(x)}^\nu \leq f(x) \leq U_{f(x)}^\nu \\ 1 & \text{if } f(x) \geq U_{f(x)}^\nu \end{cases} \quad (14.111)$$

and exponential and hyperbolic membership for membership and non-membership functions as follows

$$\mu_{f(x)}(f(x)) = \begin{cases} 1 & \text{if } f(x) \leq L_{f(x)}^\mu \\ 1 - \exp \left\{ -\psi \left( \frac{U_{f(x)}^\mu - f(x)}{U_{f(x)}^\mu - L_{f(x)}^\mu} \right) \right\} & \text{if } L_{f(x)}^\mu \leq f(x) \leq U_{f(x)}^\mu \\ 0 & \text{if } f(x) \geq U_{f(x)}^\mu \end{cases} \quad (14.112)$$

$$v_{f(x)}(f(x)) = \begin{cases} 0 & \text{if } f(x) \leq L_{f(x)}^v \\ \frac{1}{2} + \frac{1}{2} \tanh \left\{ \left( f(x) - \frac{U_{f(x)}^v + L_{f(x)}^v}{2} \right) \tau_{f(x)} \right\} & \text{if } L_{f(x)}^v \leq f(x) \leq U_{f(x)}^v \\ 1 & \text{if } f(x) \geq U_{f(x)}^v \end{cases} \quad (14.113)$$

**Step-4:** In this step using linear, exponential and hyperbolic function for membership and non-membership functions, we may calculate membership function for constraints as follows

$$\mu_{g_j(x)}(g_j(x)) = \begin{cases} 1 & \text{if } g_j(x) \leq b_j \\ \left( \frac{b_j + b_j^0 - g_j(x)}{b_j^0} \right) & \text{if } b_j \leq g_j(x) \leq b_j + b_j^0 \\ 0 & \text{if } g_j(x) \geq b_j + b_j^0 \end{cases} \quad (14.114)$$

$$v_{g_j(x)}(g_j(x)) = \begin{cases} 0 & \text{if } g_j(x) \leq b_j + \varepsilon_{g_j(x)} \\ \frac{g_j(x) - b_j - \varepsilon_{g_j(x)}}{b_j^0 - \varepsilon_{g_j(x)}} & \text{if } b_j + \varepsilon_{g_j(x)} \leq g_j(x) \leq b_j + b_j^0 \\ 1 & \text{if } g_j(x) \geq b_j + b_j^0 \end{cases} \quad (14.115)$$

where and for  $j = 1, 2, \dots, m$   $0 < \varepsilon_{g_j(x)}, \xi_{g_j(x)} < b_j^0$ . and

$$\mu_{g_j(x)}(g_j(x)) = \begin{cases} 1 & \text{if } g_j(x) \leq b_j \\ 1 - \exp \left\{ -\psi \left( \frac{U_{g_j(x)}^\mu - g_j(x)}{U_{g_j(x)}^\mu - L_{g_j(x)}^\mu} \right) \right\} & \text{if } b_j \leq g_j(x) \leq b_j + b_j^0 \\ 0 & \text{if } g_j(x) \geq b_j + b_j^0 \end{cases} \quad (14.116)$$

$$v_{g_j(x)}(g_j(x)) = \begin{cases} 0 & \text{if } g_j(x) \leq b_j + \varepsilon_{g_j(x)} \\ \frac{1}{2} + \frac{1}{2} \tanh \left\{ \left( g_j(x) - \frac{2b_j + b_j^0 + \varepsilon_{g_j(x)}}{2} \right) \tau_{g_j(x)} \right\} & \text{if } b_j + \varepsilon_{g_j(x)} \leq g_j(x) \leq b_j + b_j^0 \\ 1 & \text{if } g_j(x) \geq b_j + b_j^0 \end{cases} \quad (14.117)$$

where  $\psi, \tau$  are non-zero parameters prescribed by the decision maker and for

$j = 1, 2, \dots, m$   $0 < \varepsilon_{g_j(x)}, \xi_{g_j(x)} < b_j^0$ .

**Step-5:** Now using IFO for single objective optimization technique the optimization problem (P14.17) can be formulated as

**(P14.20)**

**Model-I**

$$\text{Maximize } (\alpha - \beta) \quad (14.118)$$

such that

$$\mu_{f(x)}(x) \geq \alpha; \mu_{g_j}(x) \geq \alpha; \quad (14.119)$$

$$v_{f(x)}(x) \leq \beta; v_{g_j}(x) \leq \beta; \quad (14.120)$$

$$\alpha + \beta \leq 1; \alpha \geq \beta \quad (14.121)$$

$$\alpha, \beta \in [0,1] \quad (14.122)$$

Now the above problem (P14.20) can be simplified to following crisp linear programming problem for linear membership function as

**(P14.21)**

$$\text{Maximize } (\alpha - \beta) \quad (14.123)$$

such that

$$f(x) + (U^\mu - L^\mu) \cdot \alpha \leq U^\mu; \quad (14.124)$$

$$f(x) + (U_{f(x)}^v - L_{f(x)}^v) \cdot \beta \leq L_{f(x)}^v; \quad (14.125)$$

$$\alpha + \beta \leq 1; \alpha \geq \beta; \alpha, \beta \in [0,1]; \quad (14.126)$$

$$g_j(x) \leq b_j \quad x \geq 0, \quad (14.127)$$

and for non linear membership function as

**(P14.22)**

$$\text{Maximize } (\theta - \eta) \quad (14.128)$$

such that

$$f(x) + \theta \frac{(U_{f(x)}^\mu - L_{f(x)}^\mu)}{\psi} \leq U_{f(x)}^\mu; \quad (14.129)$$

$$f(x) + \frac{\eta}{\tau_{f(x)}} \leq \frac{U_{f(x)}^\mu + L_{f(x)}^\mu + \varepsilon_{f(x)}}{2}; \quad (14.130)$$

$$g_j(x) + \theta \frac{b_j^0}{\psi} \leq b_j + b_j^0; \quad (14.131)$$

$$g_j(x) + \frac{\eta}{\tau_{g_j(x)}} \leq \frac{2b_j + b_j^0 + \varepsilon_{g_j(x)}}{2}; \quad (14.132)$$

$$\theta + \eta \leq 1; \theta \geq \eta; \theta, \eta \in [0, 1] \quad (14.133)$$

$$\text{where } \theta = -\ln(1 - \alpha); \quad (14.134)$$

$$\psi = 4; \quad (14.135)$$

$$\tau_{f(x)} = \frac{6}{(U_{f(x)}^v - L_{f(x)}^v)}; \quad (14.136)$$

$$\tau_{g_j(x)} = \frac{6}{(b_j^0 - \varepsilon_j)}, \text{ for } j = 1, 2, \dots, m \quad (14.137)$$

$$\eta = -\tanh^{-1}(2\beta - 1). \quad (14.138)$$

All these crisp nonlinear programming problems i.e (P14.21),(P14.22) can be solved by appropriate mathematical algorithm.

#### **14.10 Fuzzy Non-linear Programming (FNLP) Technique to Solve Multi-Objective Non-Linear Programming (MONLP)problem**

A Multi-Objective Non-Linear Programming (MONLP)problem may be considered in the following form

**(P14.23)**

$$\text{Minimize } \{f_1(x), f_2(x), \dots, f_p(x)\}^T \quad (14.139)$$

$$\text{Subject to } g_j(x) \leq b_j \quad j = 1, 2, \dots, m \quad (14.140)$$

$$x > 0 \quad (14.141)$$

Following Zimmermann [136] ,we have presented a solution algorithm to solve the MONLP Problem by fuzzy optimization technique.

**Step-1:** Solve the MONLP (P14.23) as a single objective non-linear programming problem  $p$  times by taking one of the objectives at a time and ignoring the others .These solutions are known as ideal solutions. Let  $x^i$  be the respective optimal solution for the  $i^{th}$  different objectives with same constraints and evaluate each objective values for all these  $i^{th}$  optimal solutions.



**Step-2:** From the result of step -1 determine the corresponding values for every objective for each derived solutions. With the values of all objectives at each ideal solutions ,pay-off matrix can be formulated as follows

$$\begin{array}{cccc}
 & f_1(x) & f_2(x) & \dots & f_p(x) \\
 \begin{array}{l} x^1 \\ x^2 \\ \vdots \\ x^p \end{array} & \left[ \begin{array}{cccc}
 f_1^*(x^1) & f_2^*(x^1) & \dots & f_p^*(x^1) \\
 f_1^*(x^2) & f_2^*(x^2) & \dots & f_p^*(x^2) \\
 \dots & \dots & \dots & \dots \\
 f_1^*(x^p) & f_2^*(x^p) & \dots & f_p^*(x^p)
 \end{array} \right]
 \end{array}$$

Here  $x^1, x^2, \dots, x^p$  are the ideal solutions of the objectives  $f_1(x), f_2(x), \dots, f_p(x)$  respectively.

**Step-3:** From the result of step-2, now we find lower bound (minimum)  $L_i$  and upper bound (maximum)  $U_i$  by using the following rules

$$U_i = \max \{f_i(x_p)\}, \quad (14.142)$$

$$L_i = \min \{f_i(x_p)\} \quad (14.143)$$

where  $1 \leq i \leq p$ . It is obvious  $L_i = f_i^*(x^i)$ ,  $1 \leq i \leq p$ .

**Step-4:** Using aspiration level of each objective, the MONLP (P14.23) may be written as follows

**(P14.24)**

Find  $x$  so as to satisfy (14.144)

$$f_i(x) \leq L_i \quad (i = 1, 2, \dots, p) \quad (14.145)$$

$$g_j(x) \leq b_j \quad j = 1, 2, \dots, m \quad (14.146)$$

$$x > 0 \quad (14.147)$$

Here objective function of (P14.23) are consider as fuzzy constraints. This type of fuzzy constraint can be quantified by eliciting a corresponding membership function

$$\mu_i(f_i(x)), i = 1, 2, \dots, p$$

$$\mu_i(f_i(x)) = \begin{cases} 1 & \text{if } f_i(x) \leq L_i^{ACC} \\ \frac{e^{-w\left(\frac{f_i(x)-L_i^{ACC}}{U_i^{ACC}-L_i^{ACC}}\right)} - e^{-w}}{1 - e^{-w}} & \text{if } L_i^{ACC} \leq f_i(x) \leq U_i^{ACC} \\ 0 & \text{if } f_i(x) \geq U_i^{ACC} \end{cases} \quad (14.148)$$

Under the concept of mean operator , the feasible solution set is defined by intersection of the fuzzy objective set .The feasible set is then characterized by its membership  $\mu_D(x)$  which

$$\text{is } \mu_D(x) = \min \{ \mu_1(f_1(x)), \mu_2(f_2(x)), \dots, \mu_p(f_p(x)) \} \quad (14.149)$$

The decision solution can be obtained by solving the problem of *maximize (minimize  $\mu_D(x)$ )* subject to the given constraints i.e

**(P14.25)**

$$\text{Maximize} \left( \text{Minimize} \begin{matrix} \forall x > 0 \\ \forall i \end{matrix} \mu_i(x) \right) \quad (14.150)$$

$$\text{such that } g_j(x) \leq b_j, \quad (14.151)$$

$$x > 0, \quad j = 1, 2, \dots, m, i = 1, 2, \dots, p \quad (14.152)$$

Now if suppose  $\alpha = \text{Minimize } \mu_i(x)$  be the overall satisfactory level of compromise, then we obtain the following equivalent model

**(P14.26)**

$$\text{Maximize } \alpha \quad (14.153)$$

$$\text{such that } \mu_i(x) \geq \alpha, \quad i = 1, 2, \dots, p \quad (14.154)$$

$$g_j(x) \leq b_j, \quad j = 1, 2, \dots, m \quad (14.155)$$

$$x > 0, \quad \alpha \in [0, 1] \quad (14.156)$$

**Step-5:** Solve (P14.26) to get optimal solution.

### 14.11 An Intuitionistic Fuzzy(IF) Approach for Solving Multi-Objective Non-Linear Programming(MONLP) Problem with Non-linear membership and Non-linear Non-membership Function

Following Zimmermann [140] and Angelov [3],we have presented a solution algorithm to solve MONLP (P14.23) by Intuitionistic fuzzy optimization (IFO). Here Step 1 and Step 2 are same as shown in 14.10

**Step-3:** From the result of step 2 now we find lower bound (minimum)  $L_i^{ACC}$

and upper bound (maximum)  $U_i^{ACC}$  by using following rules

$$U_i^{ACC} = \max \{f_i(x^p)\}, \quad (14.157)$$

$$L_i^{ACC} = \min \{f_i(x^p)\} \text{ where } 1 \leq i \leq p. \quad (14.158)$$

But in IFO the degree of non-membership (rejection) and the degree of membership (acceptance) are considered so that the sum of both value is less than one. To define the non-membership of NLP problem let  $U_i^{Rej}$  and  $L_i^{Rej}$  be the upper bound and lower bound of objective function  $f_i(x)$  where  $L_i^{ACC} \leq L_i^{Rej} \leq U_i^{Rej} \leq U_i^{ACC}$ . For objective function of minimization problem, the upper bound for non-membership function (rejection) is always equals to that the upper bound of membership function (acceptance). One can take lower bound for non-membership function as follows

$$L_i^{Rej} = L_i^{Acc} + \varepsilon_i \quad (14.159)$$

where  $0 < \varepsilon_i < (U_i^{Acc} - L_i^{Acc})$

based on the decision maker choice.

The initial IF model with aspiration level of objectives becomes *Find*  $\{x_i, i = 1, 2, \dots, p\}$

so as to satisfy

$$f_i(x) \leq^i L_i^{Acc} \text{ with tolerance } P_i^{Acc} = (U_i^{Acc} - L_i^{Acc}) \text{ for the degree of acceptance for } i = 1, 2, \dots, p \quad (14.160)$$

$$f_i(x) \geq^i U_i^{Rej} \text{ with tolerance } P_i^{Acc} = (U_i^{Acc} - L_i^{Acc}) \text{ for degree of rejection for } i = 1, 2, \dots, p \quad (14.161)$$

Define the membership (acceptance) and non-membership (rejection) functions of above uncertain objectives as follows. For the  $i^{th}, i = 1, 2, \dots, p$  objectives functions the linear membership function  $\mu_i(f_i(x))$  and linear non-membership  $\nu_i(f_i(x))$  is defined as follows

$$\mu_i(f_i(x)) = \begin{cases} 1 & \text{if } f_i(x) \leq L_i^{Acc} \\ \frac{e^{-w\left(\frac{f_i(x)-L_i^{Acc}}{U_i^{Acc}-L_i^{Acc}}\right)} - e^{-w}}{1 - e^{-w}} & \text{if } L_i^{Acc} \leq f_i(x) \leq U_i^{Acc} \\ 0 & \text{if } f_i(x) \geq U_i^{Acc} \end{cases} \quad (14.162)$$

$$\nu_i(f_i(x)) = \begin{cases} 0 & \text{if } f_i(x) \leq L_i^{Rej} \\ \left(\frac{f_i(x)-L_i^{Rej}}{U_i^{Rej}-L_i^{Rej}}\right)^2 & \text{if } L_i^{Rej} \leq f_i(x) \leq U_i^{Rej} \\ 1 & \text{if } f_i(x) \geq U_i^{Rej} \end{cases} \quad (14.163)$$

**Step-4:** Now an IFO problem for above problem with membership and non-membership functions can be written as

**(P14.27)**

$$\text{Maximize}_{\forall i} (\mu_i(f_i(x))) \quad (14.164)$$

$$\text{Minimize}_{\forall i} (\nu_i(f_i(x))) \quad (14.165)$$

$$\text{subject to } \mu_i(f_i(x)) + \nu_i(f_i(x)) < 1 \quad (14.166)$$

$$(\mu_i(f_i(x))) > (\nu_i(f_i(x))); \quad (14.167)$$

$$(\nu_i(f_i(x))) \geq 0; \quad (14.168)$$

$$g_j(x) \leq 0; \quad (14.169)$$

$$x > 0 \quad (14.170)$$

$$i = 1, 2, \dots, p; j = 1, 2, \dots, m$$

Find an equivalent crisp model by using membership and non-membership functions of objectives by IF decision making as follows

**(P14.28)**

$$\text{Max} \left( \text{Min}(\mu_1, \mu_2, \dots, \mu_p) \right) - \text{Min} \left( \text{Max}(\nu_1, \nu_2, \dots, \nu_p) \right) \quad (14.171)$$

$$\text{subject to } \mu_i(f_i(x)) + \nu_i(f_i(x)) < 1 \quad (14.172)$$

$$(\mu_i(f_i(x))) > (\nu_i(f_i(x))); \quad (14.173)$$

$$(\nu_i(f_i(x))) \geq 0; \quad (14.174)$$

$$\begin{aligned}
g_j(x) &\leq 0; \\
x &> 0 \\
i &= 1, 2, \dots, p; j = 1, 2, \dots, m
\end{aligned} \tag{14.175}$$

If we consider

$$\alpha = \text{Minimize}(\mu_1, \mu_2, \dots, \mu_p); \tag{14.176}$$

$$\beta = \text{Maximize}(v_1, v_2, \dots, v_p) \tag{14.177}$$

accordingly the Angelov [4], the above can be written as

**(P14.29)**

$$\text{Maximize } (\alpha - \beta) \tag{14.178}$$

$$\text{subject to } \mu_i(f_i(x)) \geq \alpha; \tag{14.179}$$

$$g_j(x) \leq 0; \tag{14.180}$$

$$x > 0, \alpha + \beta \leq 1 \tag{14.181}$$

$$\alpha \in [0, 1], \beta \in [0, 1]; i = 1, 2, \dots, p \tag{14.182}$$

$$j = 1, 2, \dots, m \tag{14.183}$$

which on substitution of  $\mu_i(f_i(x))$  and  $v_i(f_i(x))$  for  $i = 1, 2, \dots, p$  becomes

**(P14.30)**

$$\text{Maximize } (\alpha - \beta) \tag{14.184}$$

subject to

$$f_i(x) + \frac{U_i^{Acc} - L_i^{Acc}}{w} \ln\{(1 - e^{-w})\alpha + e^{-w}\} \leq L_i^{Acc}; \tag{14.185}$$

$$f_i(x) - \sqrt{\beta}(U_i^{Rej} - L_i^{Rej}) \leq L_i^{Rej}; \tag{14.186}$$

$$g_j(x) \leq 0; \tag{14.187}$$

$$\alpha + \beta \leq 1; \tag{14.188}$$

$$\alpha \in [0, 1], \beta \in [0, 1] \tag{14.189}$$

$$i = 1, 2, \dots, p; j = 1, 2, \dots, m \tag{14.190}$$

**Step-5:** Solve the above crisp model (P14.30) by using appropriate mathematical programming algorithm to get optimal solution of objective function.

**Step-6:** Stop.

## 14.12 Intuitionistic Fuzzy Non-linear Programming (IFNLP) Optimization to solve Parametric Multi-Objective Non-linear Programming Problem (PMONLP)

A multi-objective IFNLP problem with imprecise co-efficient can be formulated as

**(P14.31)**

$$\text{Minimize } \tilde{f}_{k_0}(x) = \sum_{t=1}^{T_{k_0}} \xi_{k_0 t} \tilde{c}_{k_0 t} \prod_{j=1}^n x_j^{a_{k_0 t j}} \text{ for } k_0 = 1, 2, \dots, p \quad (14.191)$$

$$\text{Such that } \tilde{f}_i(x) = \sum_{t=1}^{T_i} \xi_{it} \tilde{c}_{it} \prod_{j=1}^n x_j^{a_{ij}} \leq \xi_i \tilde{b}_i \text{ for } i = 1, 2, \dots, m \quad (14.192)$$

$$x_j > 0 \quad j = 1, 2, \dots, n \quad (14.193)$$

Here  $\xi_{k_0 t}$ ,  $\xi_{it}$ ,  $\xi_i$  are the signum function used to indicate sign of term in the equation.

$\tilde{c}_{k_0 t} > 0$ ,  $\tilde{c}_{it} > 0$ .  $a_{k_0 t j}$ ,  $a_{ij}$  are real numbers for all  $i, t, k_0, j$ .

$$\text{Here } \tilde{c}_{k_0 t} = \left( (c_{k_0 t}^{1\mu}, c_{k_0 t}^2, c_{k_0 t}^{3\mu}; w_{k_0 t}) (c_{k_0 t}^{1\nu}, c_{k_0 t}^2, c_{k_0 t}^{3\nu}; \tau_{k_0 t}) \right); \quad (14.194)$$

$$\tilde{c}_{it} = \left( (c_{it}^{1\mu}, c_{it}^2, c_{it}^{3\mu}; w_{it}) (c_{it}^{1\nu}, c_{it}^2, c_{it}^{3\nu}; \tau_{it}) \right);$$

(14.195)

$$\tilde{b}_i = \left( (b_i^{1\mu}, b_i^2, b_i^{3\mu}; w_i) (b_i^{1\nu}, b_i^2, b_i^{3\nu}; \tau_i) \right) \quad (14.196)$$

Using total integral value of membership and non-membership functions, we transform above multi-objective intuitionistic programming with imprecise parameter as

**(P14.32)**

$$\text{Minimize } \hat{f}_{1k_0}(x; \alpha) = \sum_{t=1}^{T_{k_0}} \xi_{k_0 t} \hat{c}_{1k_0 t} \prod_{j=1}^n x_j^{a_{k_0 t j}} \text{ for } k_0 = 1, 2, \dots, p \quad (14.197)$$

$$\text{Minimize } \hat{f}_{2k_0}(x; \beta) = \sum_{t=1}^{T_{k_0}} \xi_{k_0 t} \hat{c}_{2k_0 t} \prod_{j=1}^n x_j^{a_{k_0 t j}} \text{ for } k_0 = 1, 2, \dots, p \quad (14.198)$$

$$\text{Such that } \hat{f}_{1i}(x; \alpha) = \sum_{t=1}^{T_i} \xi_{it} \hat{c}_{1it} \prod_{j=1}^n x_j^{a_{ij}} \leq \xi_i \hat{b}_{1i} \text{ for } i = 1, 2, \dots, m \quad (14.199)$$

$$\hat{f}_{2i}(x; \beta) = \sum_{t=1}^{T_i} \xi_{it} \hat{c}_{2it} \prod_{j=1}^n x_j^{a_{ij}} \leq \xi_i \hat{b}_{2i} \text{ for } i = 1, 2, \dots, m \quad (14.200)$$

$$x_j > 0; \alpha, \beta \in [0, 1] \quad j = 1, 2, \dots, n \quad (14.201)$$

Here  $\xi_{k_0^t}, \xi_{it}, \xi_i$  are the signum functions used to indicate sign of term in the equation.

$\hat{c}_{1k_0^t} > 0, \hat{c}_{1it} > 0; \hat{b}_{1i} > 0$  denote the total integral value of membership function i.e

$$\hat{c}_{1k_0^t} = \frac{c_{k_0^t}^2 + (2w_{k_0^t} - 1)\{\alpha c_{k_0^t}^{3\mu} + (1-\alpha)c_{k_0^t}^{1\mu}\}}{2w_{k_0^t}}, \quad (14.202)$$

$$\hat{c}_{1it} = \frac{c_{it}^2 + (2w_{it} - 1)\{\alpha c_{it}^{3\mu} + (1-\alpha)c_{it}^{1\mu}\}}{2w_{it}} \quad (14.203)$$

and  $\hat{b}_{1i} = \frac{b_i^2 + (2w_i - 1)\{\alpha b_i^{3\mu} + (1-\alpha)b_i^{1\mu}\}}{2w_i}$  (14.204)

and  $\hat{c}_{2k_0^t} > 0, \hat{c}_{2it} > 0; \hat{b}_{2i} > 0$  denote the total integral value of non-membership function ie

$$\hat{c}_{2k_0^t} = \frac{c_{k_0^t}^2 + (2\tau_{k_0^t} - 1)\{\beta c_{k_0^t}^{3\nu} + (1-\beta)c_{k_0^t}^{1\nu}\}}{2\tau_{k_0^t}}, \quad (14.205)$$

$$\hat{c}_{2it} = \frac{c_{it}^2 + (2\tau_{it} - 1)\{\beta c_{it}^{3\nu} + (1-\beta)c_{it}^{1\nu}\}}{2\tau_{it}} \quad (14.206)$$

and

$$\hat{b}_{2i} = \frac{b_i^2 + (2\tau_i - 1)\{\beta b_i^{3\nu} + (1-\beta)b_i^{1\nu}\}}{2\tau_i} \quad (14.207)$$

A Parametric Multi-Objective Intuitionistic Fuzzy Non-Linear Programming (PMOIFNLP) Problem can be formulated as

**(P14.33)**

$$\text{Minimize } \{f_1(x; \alpha), f_2(x; \alpha), \dots, f_p(x; \alpha), f_1(x; \beta), f_2(x; \beta), \dots, f_p(x; \beta)\}^T \quad (14.208)$$

$$\text{Subject to } g_j(x; \alpha) \leq b_j; \quad j = 1, 2, \dots, m \quad (14.209)$$

$$g_j(x; \beta) \leq b_j; \quad j = 1, 2, \dots, m \quad (14.210)$$

$$x > 0, \alpha, \beta \in [0, 1] \quad (14.211)$$

Following Zimmermann [140] we have presented a solution algorithm to solve the PMOIFNLP Problem by fuzzy optimization technique.

**Step-1:** Solve the PMOIFNLP (P14.33) as a SONLPP  $p$  times by taking one of the objectives at a time and ignoring the others. These solutions are known as ideal solutions. Let  $x^i$  be the respective optimal solution for the  $i^{\text{th}}$  different objectives with same constraints and evaluate each objective values for all these  $i^{\text{th}}$  optimal solutions.

**Step-2:** From the result of step -1 determine the corresponding values for every objective for each derived solutions. With the values of all objectives at each ideal solutions ,pay-off matrix can be formulated as follows

$$\begin{array}{c}
 f_1(x;\alpha) \quad \dots \quad f_p(x;\alpha) \quad f_1(x;\beta) \quad \dots \quad f_p(x;\beta) \\
 \begin{array}{l}
 x^1 \\
 x^2 \\
 \vdots \\
 x^{2^p}
 \end{array}
 \left[ \begin{array}{cccccc}
 f_1^*(x^1;\alpha) & \dots & f_p^*(x^1;\alpha) & f_1^*(x^1;\beta) & \dots & f_p^*(x^1;\beta) \\
 f_1^*(x^2;\alpha) & \dots & f_p^*(x^2;\alpha) & f_1^*(x^2;\beta) & \dots & f_p^*(x^2;\beta) \\
 \dots & \dots & \dots & \dots & \dots & \dots \\
 f_1^*(x^{2^p};\alpha) & \dots & f_p^*(x^{2^p};\alpha) & f_1^*(x^{2^p};\beta) & \dots & f_p^*(x^{2^p};\beta)
 \end{array} \right]
 \end{array}$$

Here  $x^1, x^2, \dots, x^p$  is the ideal solutions of the objectives  $f_1(x;\alpha), f_2(x;\alpha), \dots, f_p(x;\alpha), f_1(x;\beta), f_2(x;\beta), \dots, f_p(x;\beta)$  respectively.

**Step-3:** From the result of step 2 now we find lower bound (minimum)  $L_i^{ACC}$

and upper bound (maximum)  $U_i^{ACC}$  by using following rules

$$U_i^{ACC} = \max\{f_i(x^p;\alpha), f_i(x^p;\beta)\}, \quad (14.212)$$

$$L_i^{ACC} = \min\{f_i(x^p;\alpha), f_i(x^p;\beta)\} \quad (14.213)$$

where  $1 \leq i \leq p$ . But in IFO The degree of non-membership (rejection) and the degree of membership (acceptance) are considered so that the sum of both value is less than one. To define the non -membership of NLP problem let  $U_i^{Rej}$  and  $L_i^{Rej}$  be the upper bound and lower bound of objective function  $f_i(x,\alpha), f_i(x,\beta)$  where  $L_i^{ACC} \leq L_i^{Rej} \leq U_i^{Rej} \leq U_i^{ACC}$ . For objective function of minimization problem ,the upper bound for non-membership function (rejection) is always equal to that the upper bound of membership function (acceptance). One can take lower bound for non-membership function as follows

$$L_i^{Rej} = L_i^{Acc} + \varepsilon_i \quad (14.214)$$

where  $0 < \varepsilon_i < (U_i^{Acc} - L_i^{Acc})$  based on the decision maker choice.

The initial IF model with aspiration level of objectives becomes

*Find*

$$\{x_i, i = 1, 2, \dots, p\} \quad (14.215)$$

so as to satisfy  $f_i(x) \leq^i L_i^{Acc}$  with tolerance  $P_i^{Acc} = (U_i^{Acc} - L_i^{Acc})$  for the degree of acceptance for  $i = 1, 2, \dots, p$ . (14.216)



$$f_i(x; s) \geq^i U_i^{\text{Rej}} \text{ with tolerance } P_i^{\text{Acc}} = (U_i^{\text{Acc}} - L_i^{\text{Acc}}) \text{ for degree of rejection for } i = 1, 2, \dots, p \quad (14.217)$$

Define the membership (acceptance) and non-membership (rejection) functions of above uncertain objectives as follows. For the  $i^{\text{th}}, i = 1, 2, \dots, p$  objective functions the linear membership functions  $\mu_i(f_i(x; \alpha))$  and  $\mu_i(f_i(x; \beta))$  and linear non-membership functions  $\nu_i(f_i(x; \alpha))$  and  $\nu_i(f_i(x; \beta))$  are defined as follows

$$\mu_i(f_i(x; \alpha)) = \begin{cases} 1 & \text{if } f_i(x; \alpha) \leq L_i^{\text{Acc}} \\ \frac{e^{-T \left( \frac{f_i(x; \alpha) - L_i^{\text{Acc}}}{U_i^{\text{Acc}} - L_i^{\text{Acc}}} \right)} - e^{-T}}{1 - e^{-T}} & \text{if } L_i^{\text{Acc}} \leq f_i(x; \alpha) \leq U_i^{\text{Acc}} \\ 0 & \text{if } f_i(x; \alpha) \geq U_i^{\text{Acc}} \end{cases} \quad (14.218)$$

$$\mu_i(f_i(x; \beta)) = \begin{cases} 1 & \text{if } f_i(x; \beta) \leq L_i^{\text{Acc}} \\ \frac{e^{-T \left( \frac{f_i(x; \beta) - L_i^{\text{Acc}}}{U_i^{\text{Acc}} - L_i^{\text{Acc}}} \right)} - e^{-T}}{1 - e^{-T}} & \text{if } L_i^{\text{Acc}} \leq f_i(x; \beta) \leq U_i^{\text{Acc}} \\ 0 & \text{if } f_i(x; \beta) \geq U_i^{\text{Acc}} \end{cases} \quad (14.219)$$

$$\nu_i(f_i(x; \alpha)) = \begin{cases} 0 & \text{if } f_i(x; \alpha) \leq L_i^{\text{Rej}} \\ \left( \frac{f_i(x; \alpha) - L_i^{\text{Rej}}}{U_i^{\text{Rej}} - L_i^{\text{Rej}}} \right)^2 & \text{if } L_i^{\text{Rej}} \leq f_i(x; \alpha) \leq U_i^{\text{Rej}} \\ 1 & \text{if } f_i(x; \alpha) \geq U_i^{\text{Rej}} \end{cases} \quad (14.220)$$

$$\nu_i(f_i(x; \beta)) = \begin{cases} 0 & \text{if } f_i(x; \beta) \leq L_i^{\text{Rej}} \\ \left( \frac{f_i(x; \beta) - L_i^{\text{Rej}}}{U_i^{\text{Rej}} - L_i^{\text{Rej}}} \right)^2 & \text{if } L_i^{\text{Rej}} \leq f_i(x; \beta) \leq U_i^{\text{Rej}} \\ 1 & \text{if } f_i(x; \beta) \geq U_i^{\text{Rej}} \end{cases} \quad (14.221)$$

**Step-4:** Now using IF probabilistic operator above problem can be written as

**(P14.34)**

$$\text{Maximize } \prod_{i=1}^p (\mu_i(f_i(x; \alpha))) (\mu_i(f_i(x; \beta)))$$

(14.222)

$$\text{Maximize } \prod_{i=1}^p (1 - \nu_i(f_i(x; \alpha)))(1 - \nu_i(f_i(x; \beta))) \quad (14.223)$$

subject to

$$0 < \mu_i(f_i(x; \alpha)) < 1; \quad (14.224)$$

$$0 < \nu_i(f_i(x; \alpha)) < 1; \quad (14.225)$$

$$0 \leq \mu_i(f_i(x; \alpha)) + \nu_i(f_i(x; \alpha)) \leq 1; \quad (14.226)$$

$$0 < \mu_i(f_i(x; \beta)) < 1; \quad (14.227)$$

$$0 < \nu_i(f_i(x; \beta)) < 1; \quad (14.228)$$

$$0 \leq \mu_i(f_i(x; \beta)) + \nu_i(f_i(x; \beta)) \leq 1; \quad (14.229)$$

$$g_j(x; \alpha) \leq b_j; \quad (14.230)$$

$$g_j(x; \beta) \leq b_j; \quad (14.231)$$

$$x > 0 \quad \alpha, \beta \in [0, 1] \quad (14.232)$$

$$i = 1, 2, \dots, p; j = 1, 2, \dots, m \quad (14.233)$$

**Step-5:** Solve the above crisp model (P14.34) by using appropriate mathematical programming algorithm to get optimal solution of objective function.

**Step-6:** Stop.

### 14.13 Fuzzy and Intuitionistic Fuzzy Non-linear Programming (IFNLP) Optimization to solve Parametric Single-Objective Non-linear Programming (PSO NLP) Problem

A multi-objective IFNLP with imprecise co-efficient can be formulated as

**(P14.35)**

$$\text{Minimize } \tilde{f}(x) = \sum_{t=1}^T \xi_t \tilde{c}_t \prod_{j=1}^n x_j^{a_{tj}} \quad (14.234)$$

$$\text{Such that } \tilde{f}_i(x) = \sum_{t=1}^{T_i} \xi_{it} \tilde{c}_{it} \prod_{j=1}^n x_j^{a_{ijt}} \leq \xi_i \tilde{b}_i^n \text{ for } i = 1, 2, \dots, m \quad (14.235)$$

$$x_j > 0 \quad j = 1, 2, \dots, n \quad (14.236)$$

Here  $\xi_t, \xi_{it}, \xi_i$  are the signum functions used to indicate sign of term in the equation.  $\tilde{c}_t > 0,$

$\tilde{c}_{it} > 0, a_{tj}, a_{ijt}$  are real numbers for all  $i, t, j.$

$$\text{Here } \tilde{c}_t = (c_t^{1\mu}, c_t^2, c_t^{3\mu}; w_t); \quad (14.237)$$

$$\tilde{c}_{it} = (c_{it}^{1\mu}, c_{it}^2, c_{it}^{3\mu}; w_{it}); \quad (14.238)$$

$$\tilde{b}_i = (b_i^{1\mu}, b_i^2, b_i^{3\mu}; w_i) \quad (14.239)$$

for fuzzy number as coefficients and

$$\tilde{c}_t = ((c_t^{1\mu}, c_t^2, c_t^{3\mu}; w_t)(c_t^{1\nu}, c_t^2, c_t^{3\nu}; \tau_t)); \quad (14.240)$$

$$\tilde{c}_{it} = ((c_{it}^{1\mu}, c_{it}^2, c_{it}^{3\mu}; w_{it})(c_{it}^{1\nu}, c_{it}^2, c_{it}^{3\nu}; \tau_{it})); \quad (14.241)$$

$$\tilde{b}_i = ((b_i^{1\mu}, b_i^2, b_i^{3\mu}; w_i)(b_i^{1\nu}, b_i^2, b_i^{3\nu}; \tau_i)) \quad (14.242)$$

for IF coefficient.

Using nearest interval approximation method for both fuzzy and IFN ,we transform all the TIFN into interval number i.e  $[c_t^L, c_t^U]$ ,  $[c_{it}^L, c_{it}^U]$ , and  $[b_i^L, b_i^U]$

Now the MOIFNLP with imprecise parameter is of the following form

**(P14.36)**

$$\text{Minimize } \hat{f}(x) = \sum_{t=1}^T \xi_{k_{qt}} \hat{c}_t \prod_{j=1}^n x_j^{a_{tj}} \quad (14.243)$$

$$\text{Such that } \hat{f}_i(x) = \sum_{t=1}^{T_i} \xi_{it} \hat{c}_{it} \prod_{j=1}^n x_j^{a_{tj}} \leq \sigma_i \hat{b}_i \text{ for } i = 1, 2, \dots, m \quad (14.244)$$

$$x_j > 0 \quad j = 1, 2, \dots, n \quad (14.245)$$

Here  $\xi_t$ ,  $\xi_{it}$ ,  $\xi_i$  are the signum functions used to indicate sign of term in the equation.  $\hat{c}_t > 0$ ,

$\hat{c}_{it} > 0$ ;  $\hat{b}_i > 0$  denote the interval component i.e

$$\hat{c}_t = [c_t^L, c_t^U], \quad (14.246)$$

$$\hat{c}_{it} = [c_{it}^L, c_{it}^U], \quad (14.247)$$

$$\text{and } \hat{b}_i = [b_i^L, b_i^U] \quad (14.248)$$

and  $a_{tj}$ ,  $a_{ij}$  are real numbers for all  $i, t, j$ .

Using parametric interval valued function the above problem transforms into

**(P14.37)**

$$\text{Minimize } f(x; s) = \sum_{t=1}^T \xi_t (c_t^L)^{1-s} (c_t^U)^s \prod_{j=1}^n x_j^{a_{tj}} \quad (14.249)$$

$$\text{such that } f_i(x; s) = \sum_{t=1}^{T_i} \xi_{it} (c_{it}^L)^{1-s} (c_{it}^U)^s \prod_{j=1}^n x_j^{a_{ij}} \leq \xi_i (b_i^L)^{1-s} (b_i^U)^s \text{ for } i=1,2,\dots,m \quad (14.250)$$

$$x_j > 0 \quad j=1,2,\dots,n \quad s \in [0,1] \quad (14.251)$$

Here  $\xi_t, \xi_{it}, \xi_i$  are the signum functions used to indicate sign of term in the equation.

This is a parametric single objective non-linear programming problem and can be solved by IFO technique.

Let us consider a Single-Objective Parametric Nonlinear Programming Problem(SOPNLPP) as

**(P14.38)**

$$\text{Minimize } f(x; s) \quad (14.252)$$

$$g_j(x; s) \leq b_j(s) \quad j=1,2,\dots,m \quad (14.253)$$

$$x \geq 0; s \in [0,1] \quad (14.254)$$

Usually constraint goals are considered as fixed quantity .But in real life problem ,the constraint goal cannot be always exact. So we can consider the constraint goal for less than type constraints at least  $b_j(s)$  and it may possible to extend to  $b_j^0(s)$  so that the maximum allowable tolerance is  $b_j^1(s)$  with  $b_j^0(s) = b_j(s) + b_j^1(s)$ . This fact seems to take the constraint goal as a IFS and which will be more realistic descriptions than others. Then the NLP becomes IFO problem with IF resources, which can be described as follows

**(P14.39)**

$$\text{Minimize } f(x; s) \quad (14.255)$$

$$g_j(x; s) \leq \tilde{b}_j^i(s) \quad j=1,2,\dots,m \quad (14.256)$$

$$x \geq 0; s \in [0,1] \quad (14.257)$$

To solve the IFO (P14.39) following Werner's [118] and Angelov [3] we are presenting a solution procedure for Single Objective Neutrosophic Optimization (SONSO) problem as follows

**Step-1:** Following Warner's approach solve the SONLP without tolerance in constraints (i.e  $g_j(x; s) \leq b_j(s)$ ), with tolerance of acceptance in constraints (i.e  $g_j(x; s) \leq b_j^0(s)$ ) by appropriate non-linear programming technique.

Here they are

**(P14.40)**

**Sub-problem-1**

$$\text{Minimize } f(x; s) \quad (14.258)$$

$$g_j(x; s) \leq b_j(s) \quad j = 1, 2, \dots, m$$

(14.259)

$$x \geq 0; s \in [0, 1] \quad (14.260)$$

**(P14.41)****Sub-problem-2**

$$\text{Minimize } f(x; s) \quad (14.261)$$

$$g_j(x; s) \leq b_j^0(s), \quad j = 1, 2, \dots, m \quad (14.262)$$

$$x \geq 0; s \in [0, 1] \quad (14.263)$$

we may get optimal solutions  $x^* = x^1, f(x^*; s) = f(x^1; s)$  and  $x^* = x^2, f(x^*; s) = f(x^2; s)$  for sub-problem 1 and 2 respectively.

**Step-2:** From the result of step 1 we now find the lower bound and upper bound of objective functions. If  $U_{f(x;s)}^\mu, U_{f(x;s)}^\nu$  be the upper bounds membership and non-membership functions for the objective respectively and  $L_{f(x;s)}^\mu, L_{f(x;s)}^\nu$  be the lower bounds of membership and non-membership functions of objective respectively then

$$U_{f(x;s)}^\mu = \max \{ f(x^1; s), f(x^2; s) \}, \quad (14.264)$$

$$L_{f(x;s)}^\mu = \min \{ f(x^1; s), f(x^2; s) \}, \quad (14.265)$$

$$U_{f(x;s)}^\nu = U_{f(x;s)}^\mu, L_{f(x;s)}^\nu = L_{f(x;s)}^\mu + \varepsilon_{f(x;s)} \quad \text{where } 0 < \varepsilon_{f(x;s)} < (U_{f(x;s)}^\mu - L_{f(x;s)}^\mu) \quad (14.266)$$

**Step-3:** In this step we calculate linear membership for membership and non-membership functions of objective as follows

$$\mu_{f(x;s)}(f(x; s)) = \begin{cases} 1 & \text{if } f(x; s) \leq L_{f(x;s)}^\mu \\ \left( \frac{U_{f(x;s)}^\mu - f(x; s)}{U_{f(x;s)}^\mu - L_{f(x;s)}^\mu} \right) & \text{if } L_{f(x;s)}^\mu \leq f(x; s) \leq U_{f(x;s)}^\mu \\ 0 & \text{if } f(x; s) \geq U_{f(x;s)}^\mu \end{cases} \quad (14.267)$$

$$\nu_{f(x;s)}(f(x;s)) = \begin{cases} 0 & \text{if } f(x;s) \leq L_{f(x;s)}^v \\ \frac{f(x;s) - L_{f(x;s)}^v}{U_{f(x;s)}^v - L_{f(x;s)}^v} & \text{if } L_{f(x;s)}^v \leq f(x;s) \leq U_{f(x;s)}^v \\ 1 & \text{if } f(x;s) \geq U_{f(x;s)}^v \end{cases} \quad (14.268)$$

**Step-4:** In this step using linear function for membership and non-membership functions, we may calculate membership and non-membership function for constraints as follows

$$\mu_{g_j(x;s)}(g_j(x;s)) = \begin{cases} 1 & \text{if } g_j(x;s) \leq b_j(s) \\ \left( \frac{b_j^0(s) - g_j(x;s)}{b_j^1(s)} \right) & \text{if } b_j(s) \leq g_j(x;s) \leq b_j^0(s) \\ 0 & \text{if } g_j(x;s) \geq b_j^0(s) \end{cases} \quad (14.269)$$

$$\nu_{g_j(x;s)}(g_j(x;s)) = \begin{cases} 0 & \text{if } g_j(x;s) \leq b_j(s) + \varepsilon_{g_j(x;s)} \\ \frac{g_j(x;s) - b_j(s) - \varepsilon_{g_j(x;s)}}{b_j^1(s) - \varepsilon_{g_j(x;s)}} & \text{if } b_j(s) + \varepsilon_{g_j(x;s)} \leq g_j(x;s) \leq b_j^0(s) \\ 1 & \text{if } g_j(x;s) \geq b_j^0(s) \end{cases} \quad (14.270)$$

where and for  $j=1,2,\dots,m$   $0 < \varepsilon_{g_j(x;s)} < b_j^1(s)$ .

$$x \geq 0; s \in [0,1] \quad (14.271)$$

**Step-5:** Now using Fuzzy and IFO for single objective optimization technique(Singh .et.al [93]) the optimization problem (P14.39) can be formulated as

**(P14.42)**

$$\text{Maximize } \alpha \quad (14.272)$$

Such that

$$\mu_{f(x;s)}(x;s) \geq \alpha; \mu_{g_j}(x;s) \geq \alpha; \quad (14.273)$$

$$\alpha \in [0,1] \quad x \geq 0; s \in [0,1] \quad (14.274)$$

and

**(P14.43)**

$$\text{Maximize } (\alpha - \beta) \quad (14.275)$$

Such that

$$\mu_{f(x)}(x) \geq \alpha; \mu_{g_j}(x;s) \geq \alpha; \quad (14.276)$$

$$v_{f(x)}(x) \leq \beta; v_{g_j}(x; s) \leq \beta; \quad (14.277)$$

$$\alpha + \beta \leq 1; \alpha \geq \beta \quad (14.278)$$

$$\alpha, \beta \in [0, 1] \quad x \geq 0; s \in [0, 1] \quad (14.279)$$

In fuzzy and IF environment respectively. Now the above problem (P14.42),(P14.43) can be Solved by appropriate mathematical programming

## Bibliography

- [1] Atanassov, K. T. (1986). Intuitionistic fuzzy sets. *Fuzzy sets and Systems*, 20(1), 87-96.
- [2] Atanassov, K. T. (1989). More on intuitionistic fuzzy sets. *Fuzzy sets and systems*, 33(1), 37-45.
- [3] Angelov, P.P.( 1995). Intuitionistic fuzzy optimization. *Notes on Intutionistic Fuzzy Sets I (2)*, 123-129.
- [4] Angelov, P. P. (1997). Optimization in an intuitionistic fuzzy environment. *Fuzzy sets and Systems*, 86(3), 299-306.
- [5] Aguirre,A.H.,Zavala,A.M.,Diharce,E.V.,Rionda ,S.B.:COPSO:Constrained Optimization via PSO Algorithm.Centre for Research in Mathematics(CIMAT).(2007).Technical report No.I-07-04/22-02-2007.
- [6] Alsina, C., Trillas, E., & Valverde, L. (1983). On some logical connectives for fuzzy sets theory. *Journal of Mathematical Analysis and Applications*, 93(1), 15-26.
- [7] Ali,Nicholas., Behdinin, Kumaran and Fawaz,Zouheir.(2003). Applicability and Viability of a GA based Finite Element Analysis Architecture for Structural Design Optimization. *Computers and Structures*, 81,2259-2271.
- [8] Abdel-Baset, M., Hezam, I. M., & Smarandache, F. (2016). Neutrosophic goal programming. *Neutrosophic Sets Syst*, 11, 112-118.
- [9] Beightler,C.S.&Phillips,D.T.(1976).Applied Geometric Programming. Wiley, New York.
- [10] Bellman, R. E., &Zadeh, L. A. (1970).Decision-making in a fuzzy environment. *Management science*, 17(4), B-141.
- [11] Bharti, S.K., & Singh , S. R. Solving Multi-objective Linear Programming Problems using Intuitionistic Fuzzy Optimization Method :A Comparative Study. *International Journal of Modelling and applications*, Vol.4,Issue.1, (2014). ,10-16.
- [12] Beightler,C.S. ,Philips,D.T. & Wilde, D.J :Foundation of optimization,Prentice hall,New Jersy ,1979.
- [13] Changwen, X. (1989). Fuzzy optimization of structures by the two-phase method. *Computers & Structures*, 31(4), 575-580.



- [14] Coello, C. A. C. (2000). Use of a self-adaptive penalty approach for engineering optimization problems. *Computers in Industry*, 41(2), 113-127.
- [15] Coello Coello, C.A., Montes, E.M. (2002). Constraint-handling techniques in genetic algorithms through dominance based tournament selection. *Advanced Engineering Informatics*, 16, 193-203.
- [16] Coello Coello, C. A., & Becerra, R. L. (2004). Efficient evolutionary optimization through the use of a cultural algorithm. *Engineering Optimization*, 36(2), 219-236.
- [17] Congress, I. R. (2002). Guidelines for the design of plain jointed rigid pavements for highways. IRC.
- [18] Cao, B.Y. (1987). Solution and theory of question for a kind of fuzzy positive geometric program. *Proceeding of the second IFSA Congress, Tokyo, 1*, 205-208.
- [19] Charia, T., Roy, A. (2008). A new Measure using Intuitionistic Fuzzy Set Theory and Its Application to Edge Detection. *Applied Soft Computing*, 8(2), 917-927.
- [20] Chen, S.H. (1985). Operations in Fuzzy Numbers with Function Principal. *Tamkang Journal of Management Science*, 6(1), 13-25.
- [21] Chibani, L. (2012). *Optimum design of structures: with special reference to alternative loads using geometric programming* (Vol. 50). Springer Science & Business Media.
- [22] Coello Coello, C.A., Montes, E.M. (2002). Constraint-handling techniques in genetic algorithms through dominance based tournament selection. *Advanced Engineering Informatics*, 16, 193-203.
- [23] Coello Coello, C. A., & Becerra, R. L. (2004). Efficient evolutionary optimization through the use of a cultural algorithm. *Engineering Optimization*, 36(2), 219-236.
- [24] Charns, A., & Cooper, R. (1961). Management Models and Industrial Application of Linear Programming.
- [25] Cagnina, L. C., Esquivel, S. C., & Coello, C. A. C. (2008). Solving engineering optimization problems with the simple constrained particle swarm optimizer. *Informatica*, 32(3).
- [26] Chvorinov, N. (1939). Control of the Solidification of Castings by Calculation. *Foundry Trade Journal*, 70(8), 95-98.
- [27] Creese, R. C. (1971). Optimal riser design by geometric programming. *AFS cast metals research journal*, 7(2), 118-121.

- [28] Creese, R. C. (1971). Dimensioning of riser for long freezing range alloys by geometric programming. *AFS cast metals research journal*, 7(4), 182-185.
- [29] Cao, B.Y. (1993). Fuzzy geometric programming. *Fuzzy Sets and Systems*, 53, 135-153.
- [30] Cao, B.Y. Fuzzy geometric programming. Kluwer Academic Publishers, Netherland 2002.
- [31] Dey, S., Roy, T.K. (2015). Multi-Objective Structural using Fuzzy and Intuitionistic Fuzzy Optimization Technique, *International Journal of Intelligent Systems and Applications*. 5, 57-65.
- [32] Dey, S., & Roy, T. K. (2014). A Fuzzy programming Technique for Solving Multi-objective Structural Problem. *International Journal of Engineering and Manufacturing*, 4(5), 24.
- [33] Dey, S., Roy, T.K. (2016). Multi-Objective Structural Design Problem Optimization using Parameterized t-norm Based on Fuzzy Optimization Programming Technique, *Journal of Intelligence and Fuzzy Systems*. 30(2), 971-982.
- [34] Dey, S., Roy, T.K. (2015). Optimum Shape Design of Structural Model with Imprecise Coefficient by Parametric Geometric Programming. *Decision Science Letters*, 4, 407-418.
- [35] Dey, S., Roy, T.K. (2014). Optimized Solution of Two Bar Truss Design using Intuitionistic Fuzzy Optimization Technique. *International Journal of Information Engineering and Electric Business*, 6(4), 45-51.
- [36] Dey, S., & Roy, T. K. (2015). Multi-objective structural optimization using fuzzy and intuitionistic fuzzy optimization technique. *International Journal of Intelligent systems and applications*, 7(5), 57.
- [37] Deb, K., Pratap, A., & Moitra, S. (2000, September). Mechanical component design for multiple objectives using elitist non-dominated sorting ga. In *International Conference on Parallel Problem Solving from Nature* (pp. 859-868). Springer Berlin Heidelberg.
- [38] David, D.C.N., Stephen, S.E.A., Ajoy, J.A. (2016). Cost minimization of welded beam design problem using PSO, SA, PS, GOLDLIKE, CUCKOO, FF, FP, ALO, GSA and MVO. *International Journal of Applied Mathematics*. 5, 1-14.
- [39] Das, P., Roy, T.K. (2015). Multi-Objective Non-linear Programming Problem Based on Neutrosophic Optimization Technique and Application in Riser Design Problem. 9, 88-95.

- [40] Deb, K. (1991). Optimal design of a welded beam via genetic algorithms. *AIAA journal*, 29(11), 2013-2015.
- [41] Dey, S., & Roy, T. K. (2015). Intuitionistic Fuzzy Goal Programming Technique for Solving Non-Linear Multi-objective Structural Problem. *Journal of Fuzzy Set Valued Analysis*, 3, 179-193.
- [42] Dede, T., Bekirog .lu S, Ayvaz Y. (2011). Weight minimization of trusses with genetic algorithm. *Appl Soft Comput*, 11(2), 2565-2575.
- [43] Duffin, R.J., Peterson, E.L. and Zener, C.M., Geometric Programming Theory and Application, Wiley, New York, 1967.
- [44] Eatman, J. L., & Sealey Jr, C. W. (1979). A multiobjective linear programming model for commercial bank balance sheet management. *Journal of Bank Research*, 9(4), 227-236.
- [45] El-Wahed, W. F. A., & Lee, S. M. (2006). Interactive fuzzy goal programming for multi-objective transportation problems. *Omega*, 34(2), 158-166.
- [46] E.L.Hanan, On Fuzzy Goal Programming, *Decision Science*, 12, 522-531, 1981.
- [47] Frangopol, D. M., & Corotis, R. B. (1996, April). Reliability-based structural system optimization: state-of-the-art versus state-of-the-practice. In *Analysis and Computation*: (pp. 67-78). ASCE.
- [48] Grzegorzewski, P. (2003, September). Distances and orderings in a family of intuitionistic fuzzy numbers. In *EUSFLAT Conf.* (pp. 223-227).
- [49] Guha AL, Roy TK, Debnath M. Optimization of weight of skin plate of vertical lift gate based on fuzzy geometric programming technique. *Dam Engineering Journal*. 2013; XXIII(3):103-113.
- [50] Huang, H.Y, (2004). Pavement Analysis and Design. Second Edition, Pearson Prentice Hall, New Jersey.
- [51] He, Q., & Wang, L. (2007). An effective co-evolutionary particle swarm optimization for constrained engineering design problems. *Engineering Applications of Artificial Intelligence*, 20(1), 89-99.
- [52] He, Q., & Wang, L. (2007). A hybrid particle swarm optimization with a feasibility-based rule for constrained optimization. *Applied mathematics and computation*, 186(2), 1407-1422.
- [53] Hadi, M. N. S., & Arfiadi, Y. (2001). Optimum rigid pavement design by genetic algorithms. *Computers & Structures*, 79(17), 1617-1624.

- [54] Hajela, P., & Shih, C. J. (1990). Multiobjective optimum design in mixed integer and discrete design variable problems. *AIAA journal*, 28(4), 670-675.
- [55] Hasańcebi, O. and Azad ,S.K.( 2012). An efficient metaheuristic algorithm for engineering optimization: SOPT,*Int. j. optim. civil eng.*,2(4),479-487.
- [56] Hemaida, R. S., & Kwak, N. K. (1994). A linear goal programming model for trans-shipment problems with flexible supply and demand constraints. *Journal of the Operational Research Society*, 45(2), 215-224.
- [57] Jana, B.&Roy, T.K.(2007) .Multi-objective intuitionistic fuzzy linear programming and its application in transportation model. *Notes on Intuitionistic Fuzzy Sets*, 13 (1), 34-51.
- [58] Ji, P., Wang, J. Q., & Zhang, H. Y. (2016). Frank prioritized Bonferroni mean operator with single-valued neutrosophic sets and its application in selecting third-party logistics providers. *Neural Computing and Applications*, 1-25.
- [59] Janga Reddy, M., & Nagesh Kumar, D. (2007). An efficient multi-objective optimization algorithm based on swarm intelligence for engineering design. *Engineering Optimization*, 39(1), 49-68.
- [60] Kaveh, A., & Khayatazad, M. (2013). Ray optimization for size and shape optimization of truss structures. *Computers & Structures*, 117, 82-94.
- [61] Kaveh, A., & Talatahari, S. (2009). Particle swarm optimizer, ant colony strategy and harmony search scheme hybridized for optimization of truss structures. *Computers & Structures*, 87(5), 267-283.
- [62] Kaveh, A., & Rahami, H. (2006). Nonlinear analysis and optimal design of structures via force method and genetic algorithm. *Computers & structures*, 84(12), 770-778.
- [63] Kaveh, A., Motie, S., Mohammad, A., Moslehi, M.(2013). Magnetic charged system search: a new meta-heuristic algorithm for optimization. *Acta Mech* , 224,85-107.
- [64] Kripakaran, P.,Gupta, A.and Baugh Jr, J.W.(2007).A novel optimization approach for minimumcost design of trusses. *Computers and Structures*, 85,1782-179.
- [65] Kazemzadeh Azad, S., Hasańcebi, O., & Erol, O. K. (2011). Evaluating efficiency of big-bang big-crunch algorithm in benchmark engineering optimization problems. *Iran University of Science & Technology*, 1(3), 495-505.

- [66] Liang, R. X., Wang, J. Q., & Li, L. (2016). Multi-criteria group decision-making method based on interdependent inputs of single-valued trapezoidal neutrosophic information. *Neural Computing and Applications*, 1-20.
- [67] Lee, K. S., & Geem, Z. W. (2005). A new meta-heuristic algorithm for continuous engineering optimization: harmony search theory and practice. *Computer methods in applied mechanics and engineering*, 194(36), 3902-3933.
- [68] Levenberg, E. (2013). Analysis of pavement response to subsurface deformations. *Computers and Geotechnics*, 50, 79-88.
- [69] Li, D. F. (2010). A ratio ranking method of triangular intuitionistic fuzzy numbers and its application to MADM problems. *Computers & Mathematics with Applications*, 60(6), 1557-1570.
- [70] Luh, G.C., Lin, C.Y.(2011). Optimal design of truss-structures using particle swarm optimization. *Computers and Structures*, 89(2324)2221-2232.
- [71] Liu ,G.P., Yang, J.B. and Whidborne, J.F.,UK:Multi-objective optimization and control.
- [72] Mahdavi, M., Fesanghary, M., & Damangir, E. (2007). An improved harmony search algorithm for solving optimization problems. *Applied mathematics and computation*, 188(2), 1567-1579.
- [73] Mezura-Montes, E., & Coello, C. A. C. (2005, November). Useful infeasible solutions in engineering optimization with evolutionary algorithms. In *Mexican International Conference on Artificial Intelligence* (pp. 652-662). Springer Berlin Heidelberg.
- [74] Maser, K. R., Holland, T. J., Roberts, R., & Popovics, J. (2006). NDE methods for quality assurance of new pavement thickness. *The International Journal of Pavement Engineering*, 7(1), 1-10.
- [75] Mitchell, H. B. (2004). Ranking-intuitionistic fuzzy numbers. *International Journal of Uncertainty, Fuzziness and Knowledge-Based Systems*, 12(03), 377-386.
- [76] Mahapatra, G. S., Mitra, M., & Roy, T. K. (2010). Intuitionistic fuzzy multi-objective mathematical programming on reliability optimization model. *International journal of fuzzy systems*, 12(3), 259-266.
- [77] Mohamed, R. H. (1997). The relationship between goal programming and fuzzy programming. *Fuzzy sets and systems*, 89(2), 215-222.
- [78] Nayagam, V. L. G., Venkateshwari, G., & Sivaraman, G. (2008, June). Ranking of intuitionistic fuzzy numbers. In *Fuzzy Systems, 2008. FUZZ-IEEE*

2008.(*IEEE World Congress on Computational Intelligence*). *IEEE International Conference on* (pp. 1971-1974). IEEE.

- [79] Nehi, H. M. (2010). A new ranking method for intuitionistic fuzzy numbers. *International Journal of Fuzzy Systems*, 12(1), 80-86.
- [80] Ojha, A. K., & Das, A. K. (2010). Multi-Objective Geometric Programming Problem Being Cost Coefficients as Continuous Function with Weighted Mean Method. *arXiv preprint arXiv:1002.4002*.
- [81] Perez, R. E., & Behdinan, K. (2007). Particle swarm approach for structural design optimization. *Computers & Structures*, 85(19), 1579-1588.
- [82] Parvathi, R., & Malathi, C. ,Intuitionistic Fuzzy Linear Programming Problems. *World Applied Science Journal*, Vol.17,Issue.2, (2012), 1802-1807.
- [83] Papadrakakis, M., & Lagaros, N. D. (2002). Reliability-based structural optimization using neural networks and Monte Carlo simulation. *Computer methods in applied mechanics and engineering*, 191(32), 3491-3507.
- [84] Perez, R. E., & Behdinan, K. (2007). Particle swarm approach for structural design optimization. *Computers & Structures*, 85(19), 1579-1588.
- [85] Peng ,J-j., Wang ,J-q., Yang ,W.-E., A multi-valued neutrosophic qualitative flexible approach based on likelihood for multi-criteria decision-making problems, *International Journal of Systems Science*, 48(2):425-435, (2017).
- [86] Pal ,B.B., Moitra ,B.N. and Maulik ,U. (2003),A Goal Programming procedure for multi-objective linear programming problem,*Fuzzy Sets and Systems*,139,395-405.
- [87] Pascual, L. D., & Ben-Israel, A. (1971). Vector-valued criteria in geometric programming. *Operations Research*, 19(1), 98-104.
- [88] Report 1-26 (NCHRP, 1990) (From Hung book , chapter 2 rigid pavement)
- [89] Rao, S.S.(1987).Description and optimum Design of Fuzzy Mathematical Systems. *Journal of Mechanisms, Transmissions, and Automation in Design*, 109,126-132.
- [90] Ragsdell, K. M., & Phillips, D. T. (1976). Optimal design of a class of welded structures using geometric programming. *Journal of Engineering for Industry*, 98(3), 1021-1025.
- [91] Ramsamooj, D. V. (2000). Rational Thickness Design of an Airport Runway for Boeing 777 Aircraft Loading. *International Journal of Pavement Engineering*, 1(3), 219-231.

- [92] Rezvani, S. (2013). Ranking method of trapezoidal intuitionistic fuzzy numbers. *Annals of Fuzzy Mathematics and Informatics*, 5(3), 515-523.
- [93] Singh.B.,Sarkar M. ,Roy ,T.K., Intuitionistic Fuzzy Optimization Of Truss Design: A Comparative Study. *International Journal of Computer and Organization Trends*, 37(1), 2016, 25-33.
- [94] Smarandache, F.,(1998).Neutrosophy,Neutrosophic Probability,Set and Logic,Amer Res.Press,Rehoboth,USA,105.
- [95] Shih, C. J., & Lee, H. W. (2004). Level-cut approaches of first and second kind for unique solution design in fuzzy engineering optimization problems. *Tamkang Journal of Science and Engineering* 7(3),189-198.
- [96] Shih,C.J., Chi ,C.C.,Hsiao,J.H.(2003).Alternative  $\alpha$ -level Cuts Methods for Optimum Structural Design with Fuzzy Resources. *Computers and Structures*,81,2579-2587.
- [97] Singh.B.,Sarkar M. ,Roy ,T.K., Intuitionistic Fuzzy Optimization Of Truss Design: A Comparative Study. *International Journal of Computer and Organization Trends*, 37(1), 2016, 25-33.
- [98] Sarkar,M. , Roy ,T. K.(2016) .Intuitionistic Fuzzy Optimization on Structural Design:A Comparative Study.*International Journal of Innovative Research in Science,Engineering and Technology*.5,18471-18482.
- [99] Sarkar, M.& Roy, T.K.(2017).Truss Design Optimization with Imprecise Load and Stress in Intuitionistic Fuzzy Environment. *Journal of Ultra Scientist of Physical Sciences*, 29(2) ,12-23.
- [100] Sarkar,M. Dey, S. ,Roy ,T. K. (2016).Truss Design Optimization using Neutrosophic Optimization Technique.*Neutrosophic Sets and Systems*.13,62-69.
- [101] Sarkar,M. , Roy ,T. K. (2017).Truss Design Optimization with Imprecise Load and Stress in Neutrosophic Environment. *Advances in Fuzzy Mathematics*,12,439-474.
- [102] Sarkar,M. , Roy ,T. K. (2017).Optimization of Welded Beam with Imprecise Load and Stress by Parameterized Intuitionistic Fuzzy Optimization Technique. *Advances in Fuzzy Mathematics*.12,577-608.
- [103] Sarkar,M. , Roy ,T. K. (2017).Truss Design Optimization using Neutrosophic Optimization Technique:A Comparative Study.*Advances in Fuzzy Mathematics*.12,411-438.

- [104] Sarkar, M.; Dey, S., Roy, T. K. (2016). Neutrosophic optimization technique and its application on structural design. *Journal of Ultra Scientist of Physical Sciences*. 28, 309-321.
- [105] Sarkar, M., Roy, T. K. (2017). Multi-Objective Welded Beam Optimization using Neutrosophic Goal Programming Technique. *Advances in Fuzzy Mathematics*. 12, 515-538.
- [106] Sarkar, M., Roy, T. K. (2017). Multi-Objective Welded Beam Design Optimization using T-Norm and T-Conorm based Intuitionistic Fuzzy Optimization Technique. *Advances in Fuzzy Mathematics*. 12, 549-575.
- [107] Sarkar, M., Dey, S., & Roy, T. K. (2016). Multi-Objective Neutrosophic Optimization Technique and its Application to Structural Design. *International Journal of Computer Applications*, 148(12)
- [108] Shu, M. H., Cheng, C. H., & Chang, J. R. (2006). Using intuitionistic fuzzy sets for fault-tree analysis on printed circuit board assembly. *Microelectronics Reliability*, 46(12), 2139-2148.
- [109] Shih, C., & Chang, C. (1994, April). Mixed-discrete nonlinear fuzzy optimization for multiobjective engineering design. In *35th Structures, Structural Dynamics, and Materials Conference* (p. 1598).
- [110] Sonmez, M. (2011). Discrete optimum design of truss structures using artificial bee colony algorithm. *Struct Multidiscip Optimiz*, 43(1), 85-97.
- [111] Smarandache, F., Unifying Field in Logics Neutrosophy: Neutrosophic Probability, Set and Logic, Rehoboth, American Research Press.
- [112] Smarandache, F. (2005). Neutrosophic set-a generalization of the intuitionistic fuzzy set. *International Journal of Pure and Applied Mathematics*, 24(3), 287.
- [113] Sakawa, M. (1984). Interactive fuzzy goal programming for multiobjective nonlinear programming problems and its application to water quality management. *Control and Cybernetics*, 13, 217-228.
- [114] Sinha, S. B., Biswas, A., & Biswal, M. P. (1987). Geometric programming problems with negative degrees of difficulty. *European journal of operational research*, 28(1), 101-103.
- [115] Tian, Z. P., Wang, J., Wang, J. Q., & Zhang, H. Y. (2017). Simplified neutrosophic linguistic multi-criteria group decision-making approach to green product development. *Group Decision and Negotiation*, 26(3), 597-627



- [116] Turksen, I. B. (1986). Interval valued fuzzy sets based on normal forms. *Fuzzy sets and systems*, 20(2), 191-210.
- [117] Verma, R.K. (1990). Fuzzy Geometric Programming with several objective functions, *Fuzzy Sets and Systems*, 35, 115-120.
- [118] Werner, B. (1987) Interactive Fuzzy Programming Systems. *Fuzzy Sets and Systems*. 23, 133-178.
- [119] Wang, G. Y., Wang, W. Q., (1985). Fuzzy optimum design of structure. *Engineering Optimization*, 8, 291-300.
- [120] Wang, H., Smarandache, Y. Q. Zhang and Sunderraman, R., (2010). Single Valued Neutrosophic Sets, *Multispace and Multistructure*, 4, 410-413.
- [121] Wei, Y., Qiu, J., Karimi, H. R., & Wang, M. (2014). Model reduction for continuous-time Markovian jump systems with incomplete statistics of mode information. *International Journal of Systems Science*, 45(7), 1496-1507.
- [122] Wei, Y., Qiu, J., Karimi, H. R., & Wang, M. (2014). New results on  $H_\infty$  dynamic output feedback control for Markovian jump systems with time-varying delay and defective mode information. *Optimal Control Applications and Methods*, 35(6), 656-675.
- [123] Wei, Y., Qiu, J., Karimi, H. R., & Wang, M. (2014). Filtering design for two-dimensional Markovian jump systems with state-delays and deficient mode information. *Information Sciences*, 269, 316-331.
- [124] Wei, Y., Qiu, J., & Karimi, H. R. (2017). Reliable output feedback control of discrete-time fuzzy affine systems with actuator faults. *IEEE Transactions on Circuits and Systems I: Regular Papers*, 64(1), 170-181.
- [125] Wei, Y., Qiu, J., Lam, H. K., & Wu, L. (2016). Approaches to TS fuzzy-affine-model-based reliable output feedback control for nonlinear Itô stochastic systems. *IEEE Transactions on Fuzzy Systems*.
- [126] Wang, D., Zhang, W. H. and Jiang, J. S. (2004). Truss Optimization on Shape and Sizing with Frequency Constraints. *AIAA JOURNAL*, 42(3).
- [127] Wang, D., Zhang, W. H. and Jiang, J. S. (2002). Truss shape optimization with multiple displacement constraints. *Computer Methods in Applied Mechanics and Engineering*. 191, 3597-3612.
- [128] Wei, Y., Qiu, J., & Karimi, H. R. (2017). Reliable output feedback control of discrete-time fuzzy affine systems with actuator faults. *IEEE Transactions on Circuits and Systems I: Regular Papers*, 64(1), 170-181.

- [129] Wei, Y., Qiu, J., Lam, H. K., & Wu, L. (2016). Approaches to TS fuzzy-affine-model-based reliable output feedback control for nonlinear Itô stochastic systems. *IEEE Transactions on Fuzzy Systems*.
- [130] Wang, H., Smarandache, F., Zhang, Y., & Sunderraman, R. (2010). Single valued neutrosophic sets. *Review of the Air Force Academy*, (1), 10.
- [131] Yeh, Y.C, and Hsu, D.S. (1990). Structural optimization with fuzzy parameter. *Computer and Structure*, 37(6) , 917–924.
- [132] Yu, S. M., Wang, J., & Wang, J. Q. (2016). An extended TODIM approach with intuitionistic linguistic numbers. *International Transactions in Operational Research*.
- [133] Zadeh ,L. A. (1965).Fuzzy set, *Information and Control*,.8(3),338-353.
- [134] Zener, C. (1971). *Engineering design by geometric programming*. John Wiley & Sons.
- [135] Zhang, H. Y., Ji, P., Wang, J. Q., & Chen, X. H. (2017). A novel decision support model for satisfactory restaurants utilizing social information: a case study of TripAdvisor. com. *Tourism Management*, 59, 281-297.
- [136] Zimmermann, H. J. (1978). Fuzzy programming and linear programming with several objective functions. *Fuzzy sets and systems*, 1(1), 45-55
- [137] Zahara,E.,Kao,Y.T. (2009).Hybrid Nelder-mead simplex search and particle swarm optimization for constrained engineering design problems.*Expert System with Applications*.36,3880-3886.
- [138] Zangiabadi, M., & Maleki, H. R. (2007). Fuzzy goal programming for multiobjective transportation problems. *Journal of applied mathematics and Computing*, 24(1), 449-460.

**In the real world, uncertainty or vagueness is prevalent in engineering and management computations. Commonly, such uncertainties are included in the design process by introducing simplified hypothesis and safety or design factors. In case of structural and pavement design, several design methods are available to optimize objectives. But all such methods follow numerous monographs, tables and charts to find effective thickness of pavement design or optimum weight and deflection of structure calculating certain loop of algorithm in the cited iteration process. Most of the time, designers either only take help of a software or stop the cited procedure even after two or three iterations. As for example, the finite element method and genetic algorithm type of crisp optimization method had been applied on the cited topic, where the values of the input parameters were obtained from experimental data in laboratory scale. But practically, above cited standards have already ranged the magnitude of those parameters in between maximum to the minimum values. As such, the designer becomes puzzled to select those input parameters from such ranges which actually yield imprecise parameters or goals with three key governing factors i.e. degrees of acceptance, rejection and hesitancy, requiring fuzzy, intuitionistic fuzzy, and neutrosophic optimization.**

**Therefore, the problem of structural designs, pavement designs, welded beam designs are firstly classified into single objective and multi-objective problems of structural systems. Then, a mathematical algorithm - e.g. Neutrosophic Geometric Programming, Neutrosophic Linear Programming Problem, Single Objective Neutrosophic Optimization, Multi-objective Neutrosophic Optimization, Parameterized Neutrosophic Optimization, Neutrosophic Goal Programming Technique - has been provided to solve the problem according to the nature of impreciseness that exists in the problem.**

**Thus, we provide in this book a solution which is hardly presented in the scientific literature regarding structural optimum design, pavement optimum design, welded beam optimum design, that works in imprecise environment i.e. in neutrosophic environment.**

ISBN 978-1-59973-543-6



9 781599 735436 >